

Constructive Computer Architecture

Arvind

Computer Science & Artificial Intelligence Lab
Massachusetts Institute of Technology

6.175: L01 – September 3, 2014

6.175 Course Staff

Instructor



Arvind

arvind@csail.mit.edu

Teaching
Assistant



Andy Wright

acwright@mit.edu

Adminis-
tration



Sally Lee

sally@csail.mit.edu

For most up-to-date information and handouts please consult the course website: <http://csg.csail.mit.edu/6.175>

Computing Devices Then...

EDSAC, University of Cambridge, UK, 1949

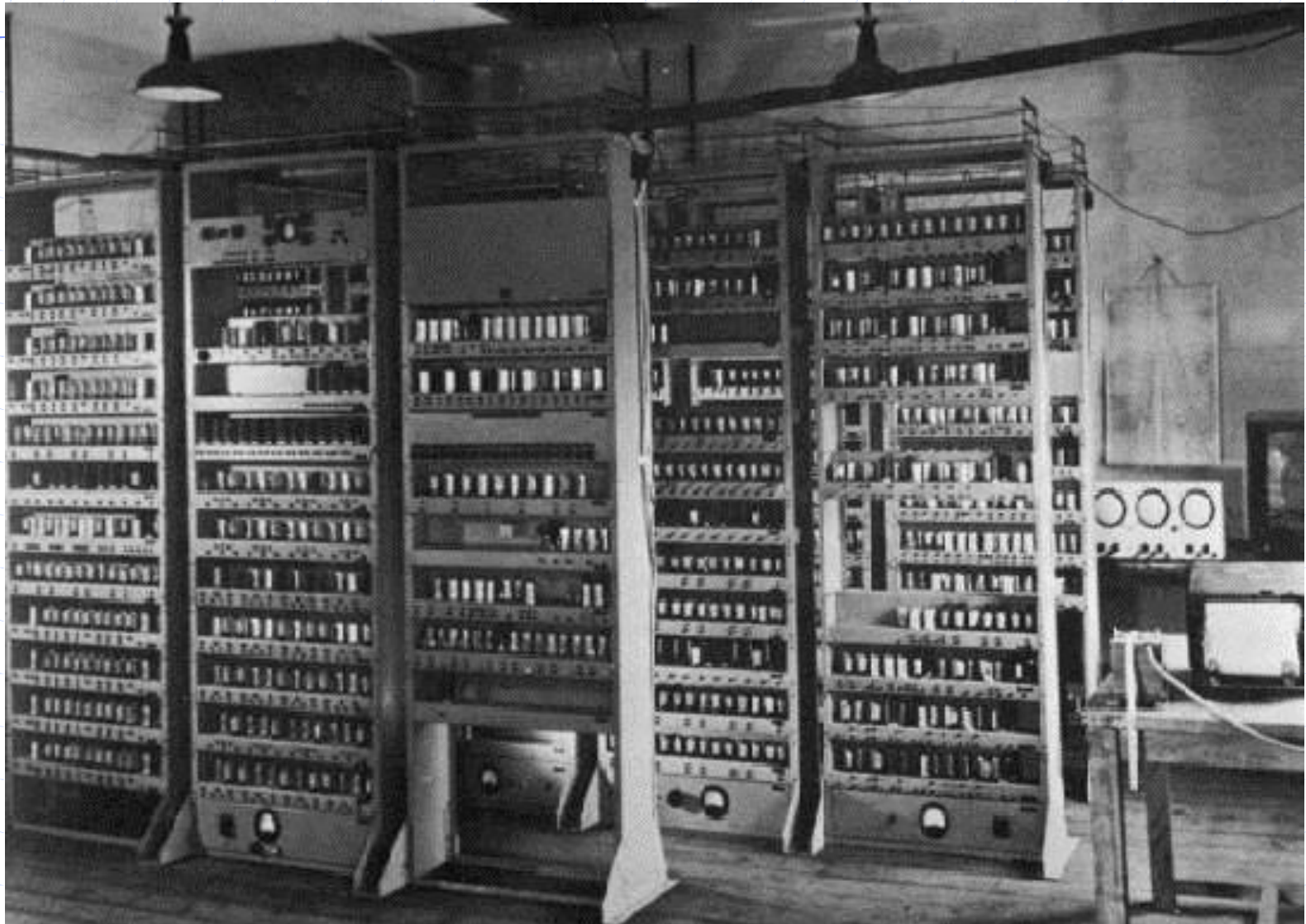

Computing Devices Now



Dramatic progress in terms of size, speed, cost, reliability

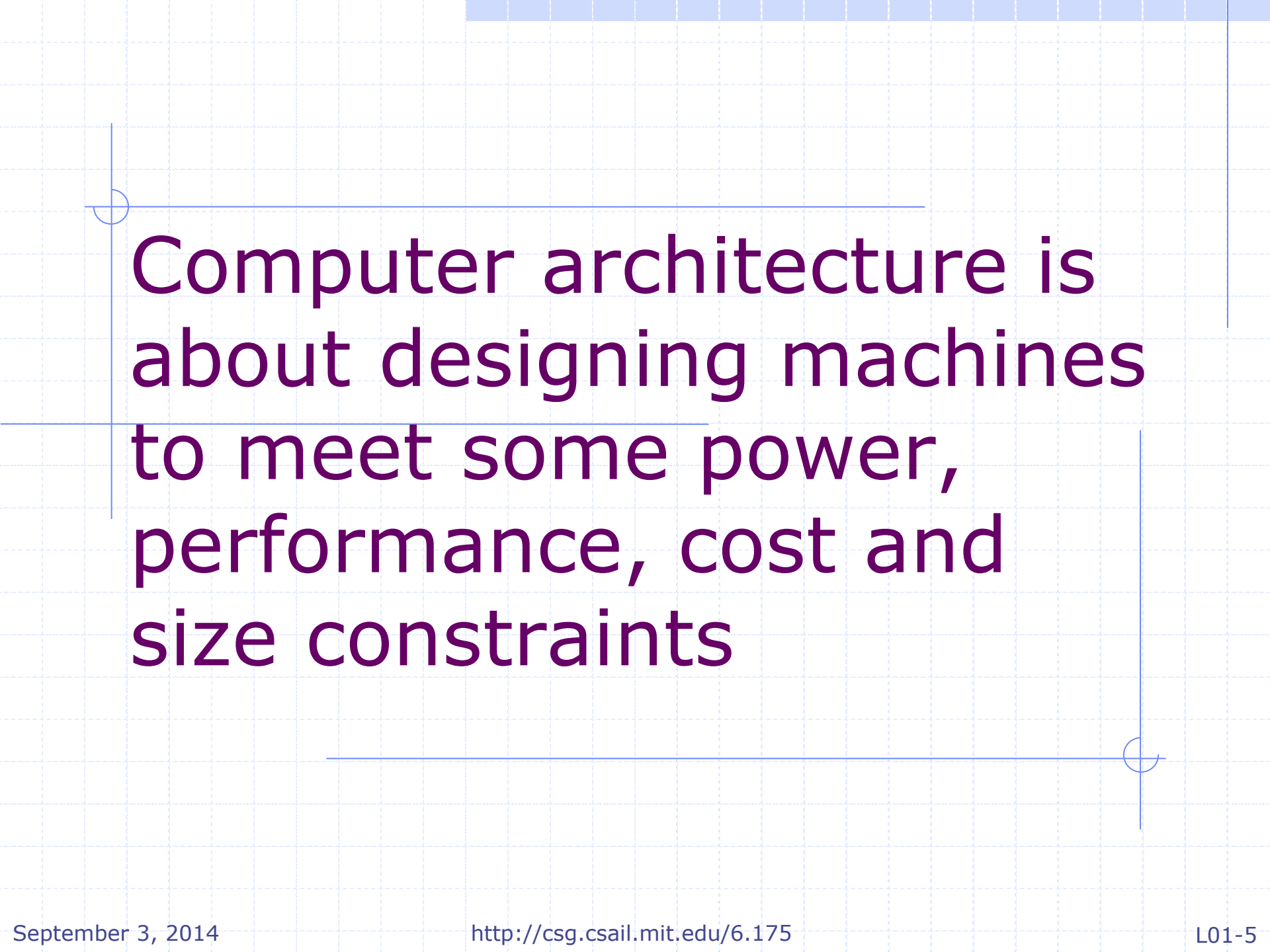

Computer architecture is about designing machines to meet some power, performance, cost and size constraints

Studying Computer Architecture

A method of constructing machines:
Machine descriptions which can be simulated in software and synthesized into hardware

This course is about "construction"

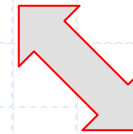
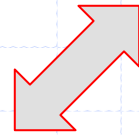

Quantitative evaluation:
To what extent designs meet various design criteria

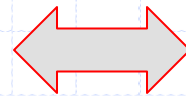

Testing and verification:
Does the machine do what it is supposed to do

Constructing and Deconstructing

A venerable method of
studying any class of artifacts

an example from the art world...

Las Meninas (The Maids of Honour) Diego Velázquez 1656

Pictures removed for copyright protection. Please visit the following link to view the pictures:

http://en.wikipedia.org/wiki/Diego_Velazquez

Portrait of
Infanta
Margarita, the
daughter of
King Philip IV,
in Royal
Alcazar, Madrid

Different lighting

Pictures removed for copyright protection. Please visit the links to view pictures:

http://en.wikipedia.org/wiki/Diego_Velazquez

Also just type "velasquez maids of honor pictures" in google

It is big!

Museo del Prado, Madrid

Pictures removed for copyright protection. Please visit the links to view pictures:

http://en.wikipedia.org/wiki/Diego_Velazquez

Also just type "velasquez maids of honor pictures" in google

Engages the viewer

Pictures removed for copyright protection. Please visit the links to view pictures:

http://en.wikipedia.org/wiki/Diego_Velazquez

Also just type "velasquez maids of honor pictures" in google

The most important painting in Western art history

Spanish tradition

El Greco

1541-1614

Francisco
de Goya

1746-1828

Diego

Velasquez

1599-1660

Pablo

Picasso

1881-1973

Pictures removed for copyright protection. Please visit the links to view pictures:

http://en.wikipedia.org/wiki/Diego_Velasquez

http://en.wikipedia.org/wiki/El_Greco

<http://en.wikipedia.org/wiki/Goya>

<http://en.wikipedia.org/wiki/Picasso>

Picasso

In fine arts one is encouraged to copy masters as a way of learning

- ◆ In 1956, at the 300th anniversary of Diego Velázquez's *Las Meninas*, Picasso revisited Madrid to see the painting
- ◆ The story goes he came back and locked himself in his studio for three months and painted 58 versions of it – deconstructing and constructing – not copying
 - All can be seen at Museu Picasso in Barcelona
- ◆ Why? Picasso was 75 and very aware of his Spanish heritage. Was he trying to improve upon the master's work?

Deconstructing & Constructing: Las Meninas

Just type “maids of honor Picasso” in google

All of Picasso’s copies of Las Meninas are the
Picasso Museum in Barcelona

Infanta Margarita

Just type “maids of honor Picasso” in google

All of Picasso’s copies of Las Meninas are the
Picasso Museum in Barcelona

Perplexed? Distracted by sun light?

Deconstructing & Constructing: Las Meninas – Infanta Margarita

Just type “maids of honor Picasso” in google

All of Picasso’s copies of Las Meninas are the
Picasso Museum in Barcelona

Deconstructing & Constructing: Las Meninas

Just type “maids of honor Picasso” in google

All of Picasso’s copies of Las Meninas are the
Picasso Museum in Barcelona

Deconstructing & Constructing: Las Meninas

Just type “maids of honor Picasso” in google

All of Picasso’s copies of Las Meninas are the
Picasso Museum in Barcelona

Deconstructing & Constructing: Las Meninas

Just type “maids of honor Picasso” in google

All of Picasso’s copies of Las Meninas are the
Picasso Museum in Barcelona

Picasso reportedly said
that I cannot improve it
but these are my Meninas

Deconstructing Microprocessors:

MIPS R10K

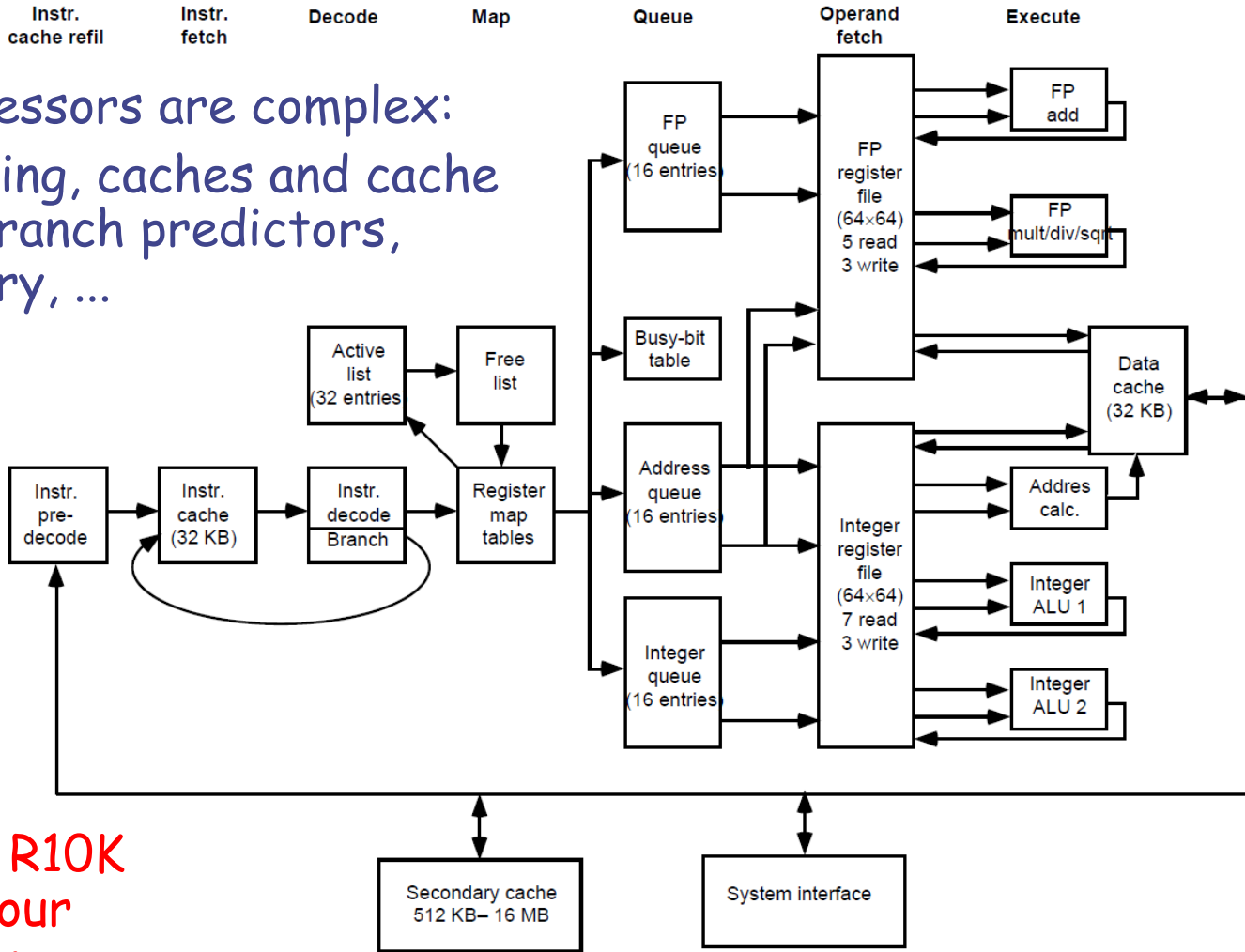

Modern processors are complex:
ALUs, pipelining, caches and cache coherence, branch predictors, virtual memory, ...

Designs must be balanced and meet some design constraints

Deconstruct R10K
to construct our
Las Maninases

Our Meninas: Various SMIPS Processors

- ◆ Non-Pipelined: 1 Cycle, 2 Cycle, 4 Cycle
- ◆ Pipelined: 2-stage with and without data hazards; pipelines with up to 6 stages
- ◆ Pipelines with multiple Branch Predictors
- ◆ Pipelines with Branch Predictors and Caches
- ◆ Pipelines with Exceptions
- ◆ Pipelines with TLBs and Virtual Memory
- ◆ Multi-core Processors with coherent shared memory

All these are evaluated quantitatively using C benchmarks run in simulation and on real hardware

The goals of this subject

- ◆ Study computer architecture by *constructing* many different machines
- ◆ Learn a new method of describing architectures where there is less emphasis on figures/diagrams and more emphasis on executable descriptions
 - Each architecture and each part of it would be defined as executable code in BSV
 - Learning BSV is about learning a model of parallel programming (all hardware is parallel)
- ◆ Learn about test benches, including designing your own
- ◆ Learn about quantitative evaluation of designs

BSV Design Flow

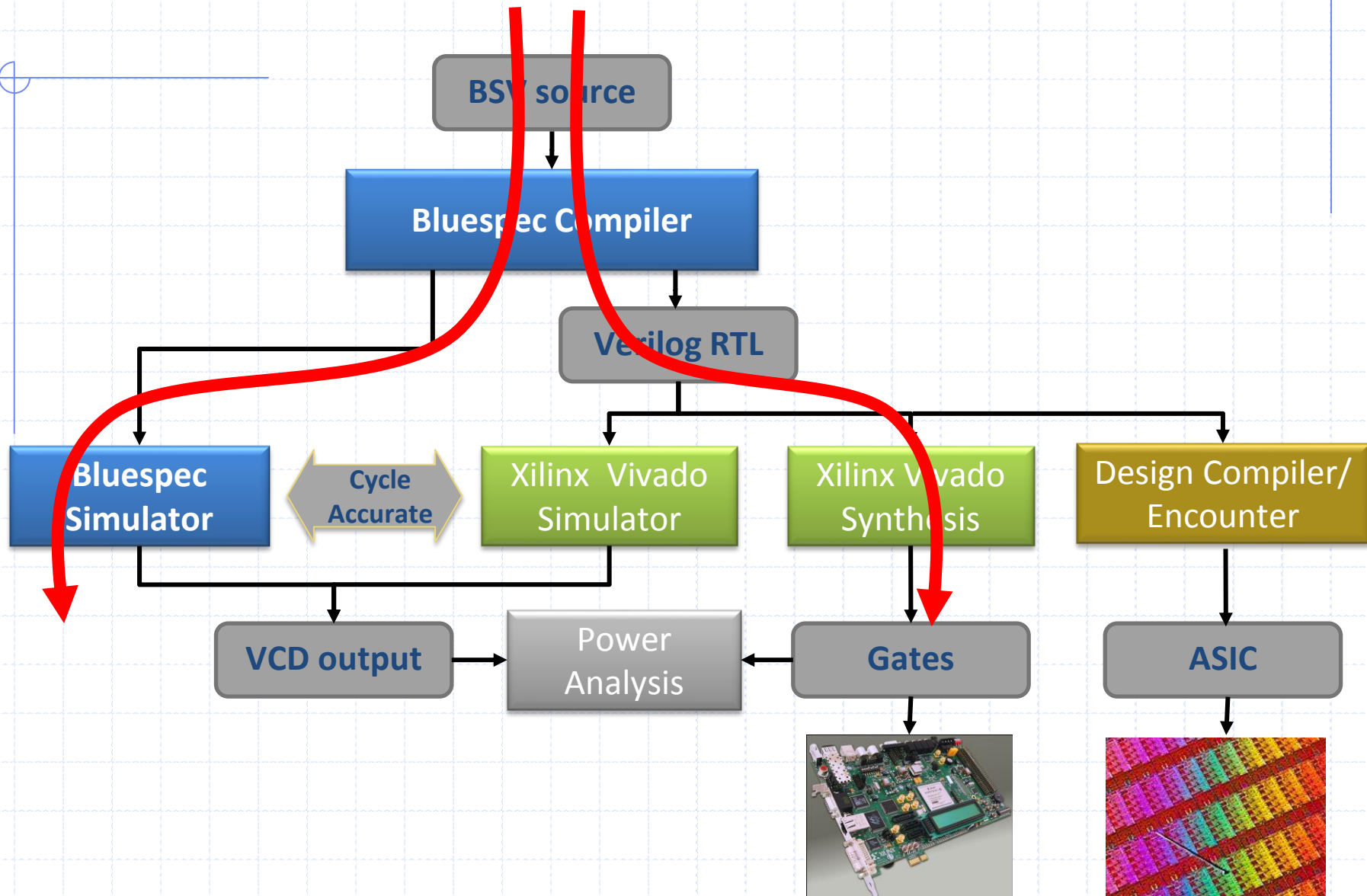

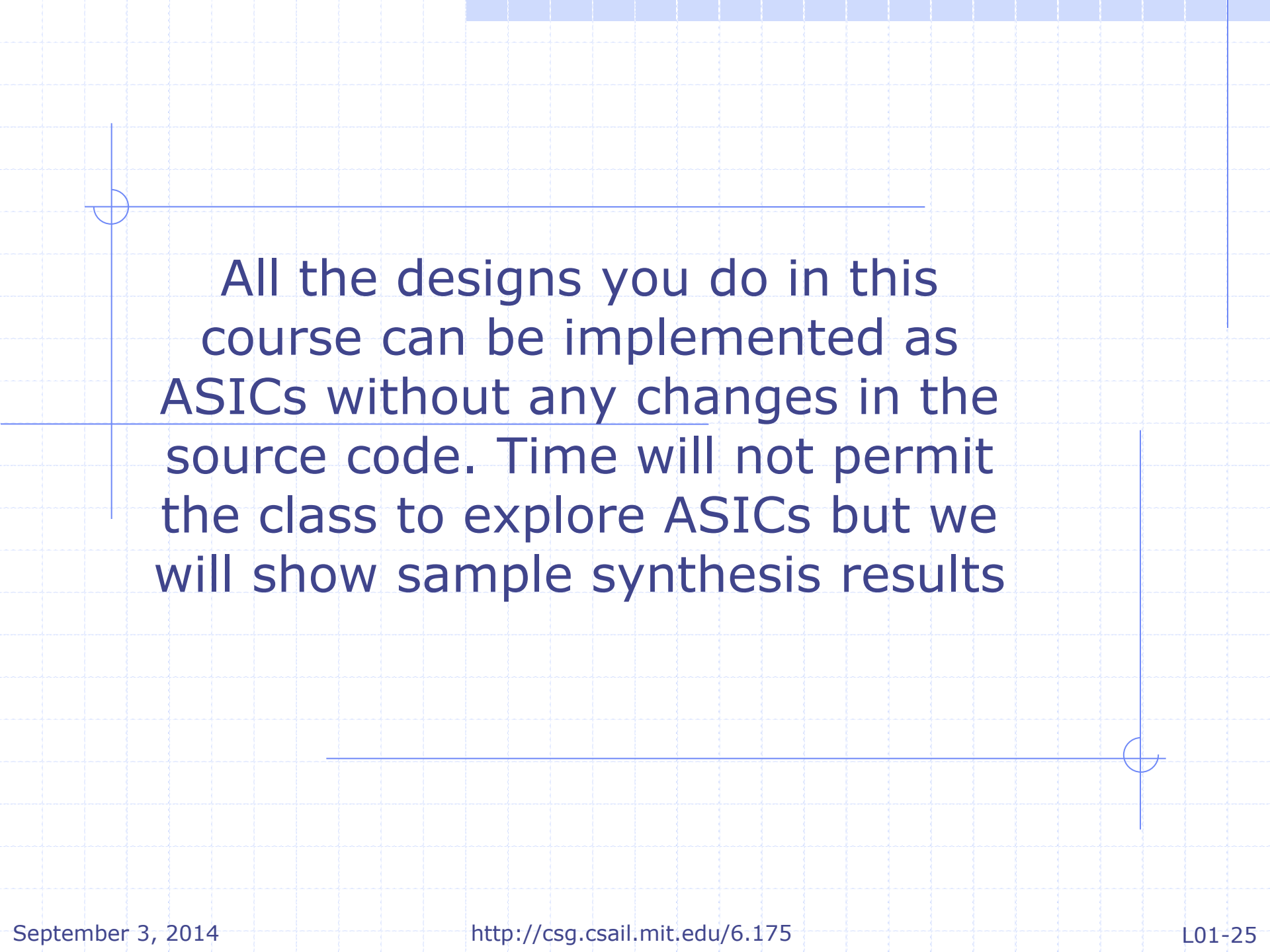

All the designs you do in this course can be implemented as ASICs without any changes in the source code. Time will not permit the class to explore ASICs but we will show sample synthesis results

Course information

- ◆ The class will meet three times a week (MWF 3pm to 4pm), accept for a few holidays
 - Typically two classes every week are lectures while the third one is a tutorial
- ◆ Eight lab assignments; to be done individually
- ◆ A project/competition in the last two weeks to produce the fastest implementation or to try out a new cool architecture idea
- ◆ Labs + project constitute 10 grade units
 - A = >75% on all 10 grade units;
 - B = >75% on 7 grade units
 - C = >50% on 7 grade units

No Quizzes

Resources

- ◆ “Computer Architecture: A Constructive Approach”, Arvind, Rishiyur Nikhil, Joel Emer and Murali Vijayaraghavan
- ◆ BSV Reference manual

For most up-to-date information and handouts please consult the course website: <http://csg.csail.mit.edu/6.175>