

# Constructive Computer Architecture

Arvind  
Computer Science & Artificial Intelligence Lab  
Massachusetts Institute of Technology

6.175: L01 – September 9, 2015

September 9, 2015

<http://csg.csail.mit.edu/6.175>

L01-1

## 6.175 Course Staff

Instructor



Arvind  
[arvind@csail.mit.edu](mailto:arvind@csail.mit.edu)

Teaching  
Assistant



Sizhuo Zhang  
[szzhang@mit.edu](mailto:szzhang@mit.edu)

Adminis-  
tration



Sally Lee  
[sally@csail.mit.edu](mailto:sally@csail.mit.edu)

For most up-to-date information and handouts please consult  
the course website: <http://csg.csail.mit.edu/6.175>

September 9, 2015

<http://csg.csail.mit.edu/6.175>

L01-2

# Computing Devices Then...

EDSAC, University of Cambridge, UK, 1949

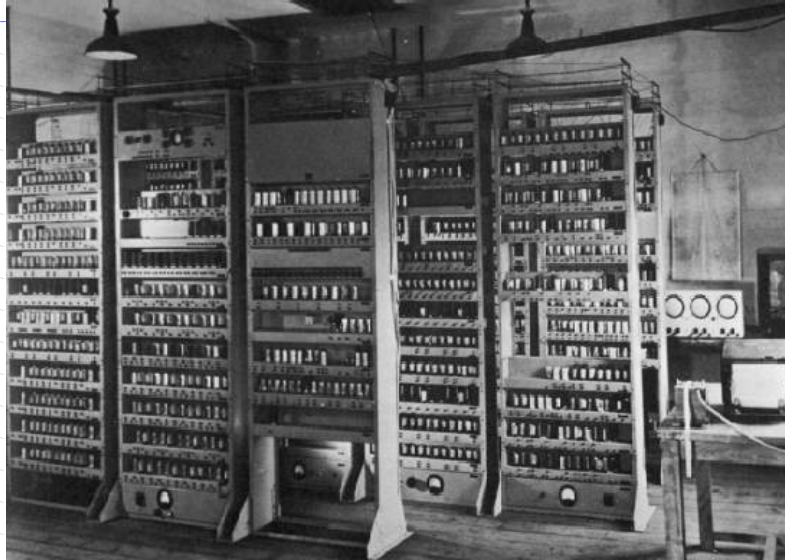

September 9, 2015

<http://csg.csail.mit.edu/6.175>

L01-3

# Computing Devices Now



Dramatic progress in terms of size, speed, cost, reliability

September 9, 2015

<http://csg.csail.mit.edu/6.175>

L01-4

Computer architecture is about designing machines to meet some power, performance, cost and size constraints

## Studying Computer Architecture

*A method of constructing machines:*  
Machine descriptions which can be simulated in software and synthesized into hardware

This course is about "construction"



*Quantitative evaluation:*  
To what extent designs meet various design criteria



*Testing and verification:*  
Does the machine do what it is supposed to do

# Constructing and Deconstructing

A venerable method of  
studying any class of artifacts

*an example from the art world...*

September 9, 2015

<http://csg.csail.mit.edu/6.175>

L01-7

## Las Meninas (The Maids of Honour) Diego Velázquez 1656

Pictures removed for copyright protection. Please visit  
the following link to view the pictures:

[http://en.wikipedia.org/wiki/Diego\\_Velazquez](http://en.wikipedia.org/wiki/Diego_Velazquez)

Portrait of  
Infanta  
Margarita, the  
daughter of  
King Philip IV,  
in Royal  
Alcazar, Madrid

September 9, 2015

<http://csg.csail.mit.edu/6.175>

L01-8

## Different lighting

Pictures removed for copyright protection. Please visit the links to view pictures:

[http://en.wikipedia.org/wiki/Diego\\_Velazquez](http://en.wikipedia.org/wiki/Diego_Velazquez)

Also just type "velasquez maids of honor pictures" in google

September 9, 2015

<http://csg.csail.mit.edu/6.175>

L01-9

## It is big!

Museo del Prado, Madrid



September 9, 2015

<http://csg.csail.mit.edu/6.175>

L01-10

## Engages the viewer

Pictures removed for copyright protection. Please visit the links to view pictures:

[http://en.wikipedia.org/wiki/Diego\\_Velasquez](http://en.wikipedia.org/wiki/Diego_Velasquez)

Also just type "velasquez maids of honor pictures" in google

The most important painting in Western art history

## Spanish tradition

El Greco  
1541–1614

Francisco  
de Goya  
1746–1828

Diego  
Velasquez  
1599-1660

Pablo  
Picasso  
1881-1973

Pictures removed for copyright protection. Please visit the links to view pictures:

[http://en.wikipedia.org/wiki/Diego\\_Velasquez](http://en.wikipedia.org/wiki/Diego_Velasquez)

[http://en.wikipedia.org/wiki/El\\_Greco](http://en.wikipedia.org/wiki/El_Greco)

<http://en.wikipedia.org/wiki/Goya>

<http://en.wikipedia.org/wiki/Picasso>

# Picasso

In fine arts one is encouraged to copy masters as a way of learning

- ◆ In 1956, at the 300<sup>th</sup> anniversary of Diego Velázquez's *Las Meninas*, Picasso revisited Madrid to see the painting
- ◆ The story goes he came back and locked himself in his studio for three months and painted 58 versions of it – deconstructing and constructing – not copying
  - All can be seen at Museu Picasso in Barcelona
- ◆ Why? Picasso was 75 and very aware of his Spanish heritage. Was he trying to improve upon the master's work?

September 9, 2015

<http://csg.csail.mit.edu/6.175>

L01-13

# Deconstructing & Constructing: Las Meninas

Just type "maids of honor Picasso" in google

All of Picasso's copies of *Las Meninas* are the Picasso Museum in Barcelona

September 9, 2015

<http://csg.csail.mit.edu/6.175>

L01-14

# Infanta Margarita

Just type "maids of honor Picasso" in google

All of Picasso's copies of Las Meninas are the  
Picasso Museum in Barcelona

Perplexed? Distracted by sun light?

September 9, 2015

<http://csg.csail.mit.edu/6.175>

L01-15

# Deconstructing & Constructing: Las Meninas – Infanta Margarita

Just type "maids of honor Picasso" in google

All of Picasso's copies of Las Meninas are the  
Picasso Museum in Barcelona

September 9, 2015

<http://csg.csail.mit.edu/6.175>

L01-16



# Deconstructing & Constructing: Las Meninas

Just type "maids of honor Picasso" in google

All of Picasso's copies of Las Meninas are the  
Picasso Museum in Barcelona

September 9, 2015

<http://csg.csail.mit.edu/6.175>

L01-17

# Deconstructing & Constructing: Las Meninas

Just type "maids of honor Picasso" in google

All of Picasso's copies of Las Meninas are the  
Picasso Museum in Barcelona

September 9, 2015

<http://csg.csail.mit.edu/6.175>

L01-18

## Deconstructing & Constructing: Las Meninas

Just type "maids of honor Picasso" in google

All of Picasso's copies of Las Meninas are the  
Picasso Museum in Barcelona

September 9, 2015

<http://csg.csail.mit.edu/6.175>

L01-19

Picasso reportedly said  
"I cannot improve it but  
these are my Meninas"

September 9, 2015

<http://csg.csail.mit.edu/6.175>

L01-20

# Deconstructing Microprocessors:

## MIPS R10K

Modern processors are complex:  
ALUs, pipelining, caches and cache coherence, branch predictors, virtual memory, ...

Designs must be balanced and meet some design constraints

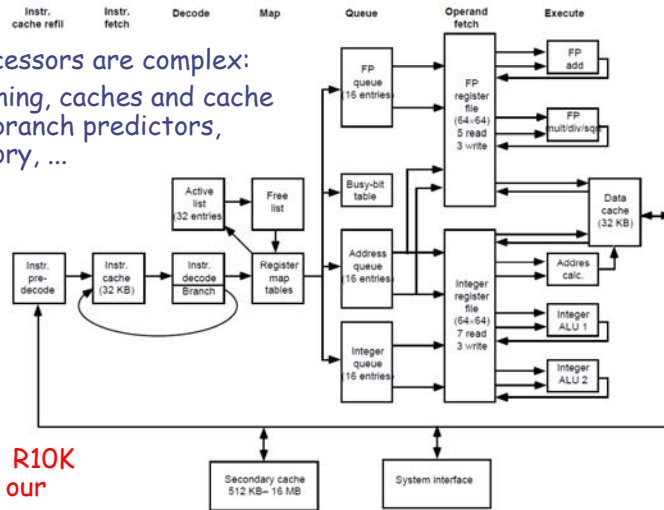

Deconstruct R10K to construct our Las Maninases

September 9, 2015

<http://csg.csail.mit.edu/6.175>

L01-21

# Our Meninas:

A new open instruction set out of Berkeley

## Various RISC V Processors

- ◆ Non-Pipelined: 1 Cycle, 2 Cycle, 4 Cycle
- ◆ Pipelined: 2-stage with and without data hazards; pipelines with up to 6 stages
- ◆ Pipelines with multiple Branch Predictors
- ◆ Pipelines with Branch Predictors and Caches
- ◆ Pipelines with Exceptions
- ◆ Pipelines with TLBs and Virtual Memory
- ◆ Non-blocking caches
- ◆ Multi-core Processors with coherent shared memory

All these are evaluated quantitatively using C benchmarks run in simulation and on real hardware

September 9, 2015

<http://csg.csail.mit.edu/6.175>

L01-22

# The goals of this subject

- ◆ Study computer architecture by *constructing* many different machines
- ◆ Learn a new method of describing architectures where there is less emphasis on figures/diagrams and more emphasis on executable descriptions
  - Each architecture and each part of it would be defined as executable code in BSV
  - Learning BSV is about learning a model of parallel programming (all hardware is parallel)
- ◆ Learn about test benches, including designing your own
- ◆ Learn about quantitative evaluation of designs

September 9, 2015

<http://csg.csail.mit.edu/6.175>

L01-23

# BSV Design Flow

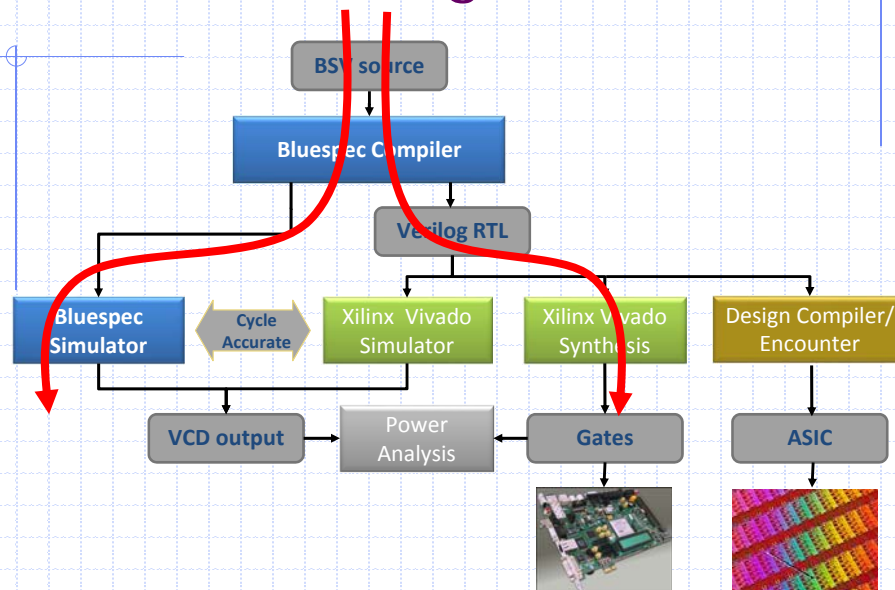

September 9, 2015

<http://csg.csail.mit.edu/6.175>

L01-24

All the designs you do in this course can be implemented as ASICs without any changes in the source code. Time will not permit the class to explore ASICs but we will show sample synthesis results

## Course information

- ◆ The class will meet three times a week (MWF 3pm to 4pm), accept for a few holidays
  - Typically two classes every week are lectures while the third one is a tutorial
- ◆ Eight lab assignments; to be done individually
- ◆ A project/competition in the last two weeks to produce the fastest implementation or to try out a new cool architecture idea
- ◆ Labs + project constitute 10 grade units
  - A = >75% on all 10 grade units;
  - B = >75% on 7 grade units
  - C = >50% on 7 grade units

No Quizzes

## Resources

- ◆ "Computer Architecture: A Constructive Approach", Arvind, Rishiyur Nikhil, Joel Emer and Murali Vijayaraghavan
- ◆ BSV Reference manual

For most up-to-date information and handouts please consult the course website: <http://csg.csail.mit.edu/6.175>

## Contributors to the course material

- ◆ Current: Arvind, Rishiyur S. Nikhil, Muralidaran Vijayaraghavan, Andrew Wright, Sizhuo Zhang
- ◆ Past:
  - Staff and students in 6.S078 (12 Spring), 6.S195 (12 Fall, 13 Fall), 6.375 (13 Spring), 6.175 (14 Fall)
    - ◆ Joel Emer, Asif Khan, Richard Uhler, Sang Woo Jun, Abhinav Agarwal, Myron King, Kermin Fleming, Ming Liu, Li-Shiuan Peh
  - External
    - ◆ Prof Amey Karkare & students at IIT Kanpur
    - ◆ Prof Jihong Kim & students at Seoul Nation University
    - ◆ Prof Derek Chiou, University of Texas at Austin
    - ◆ Prof Yoav Etsion & students at Technion
    - ◆ Prof James Hoe CMU