

Directory-Based Cache Coherence

Daniel Sanchez

Computer Science and Artificial Intelligence Lab
M.I.T.

Maintaining Cache Coherence

It is sufficient to have hardware such that

- only one processor at a time has write permission for a location
- no processor can load a stale copy of the location after a write

Maintaining Cache Coherence

It is sufficient to have hardware such that

- only one processor at a time has write permission for a location
- no processor can load a stale copy of the location after a write

⇒ A correct approach could be:

Maintaining Cache Coherence

It is sufficient to have hardware such that

- only one processor at a time has write permission for a location
- no processor can load a stale copy of the location after a write

⇒ A correct approach could be:

write request:

The address is *invalidated* in all other caches *before* the write is performed

Maintaining Cache Coherence

It is sufficient to have hardware such that

- only one processor at a time has write permission for a location
- no processor can load a stale copy of the location after a write

⇒ A correct approach could be:

write request:

The address is *invalidated* in all other caches *before* the write is performed

read request:

If a dirty copy is found in some cache, a write-back is performed before the memory is read

Directory-Based Coherence

[Censier and Feautrier, 1978]

Snoopy Protocols

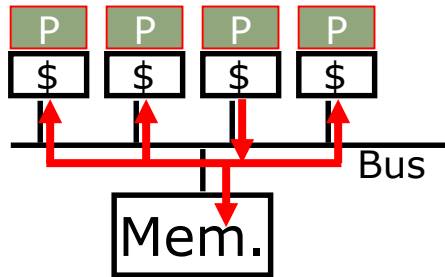

- Snoopy schemes broadcast requests over memory bus
- Difficult to scale to large numbers of processors
- Requires additional bandwidth to cache tags for snoop requests

Directory-Based Coherence

[Censier and Feautrier, 1978]

Snoopy Protocols

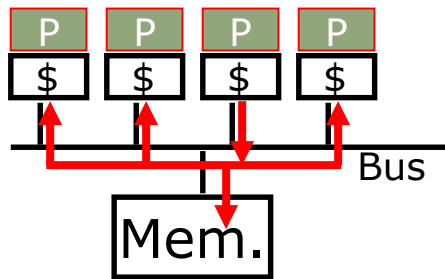

Directory Protocols

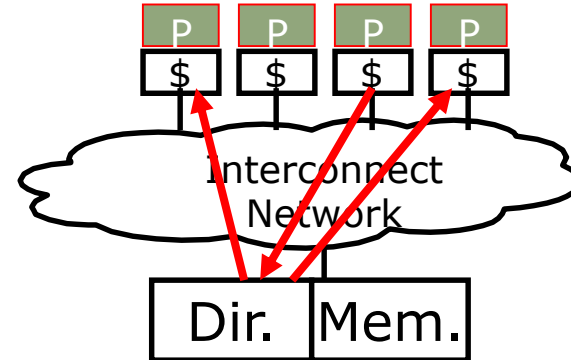

- Snoopy schemes broadcast requests over memory bus
- Difficult to scale to large numbers of processors
- Requires additional bandwidth to cache tags for snoop requests

Directory-Based Coherence

[Censier and Feautrier, 1978]

Snoopy Protocols

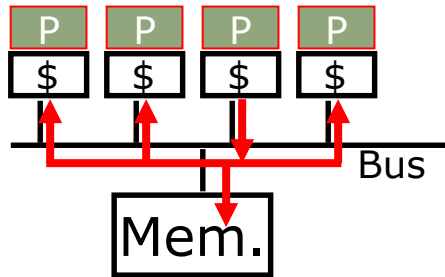

- Snoopy schemes broadcast requests over memory bus
- Difficult to scale to large numbers of processors
- Requires additional bandwidth to cache tags for snoop requests

Directory Protocols

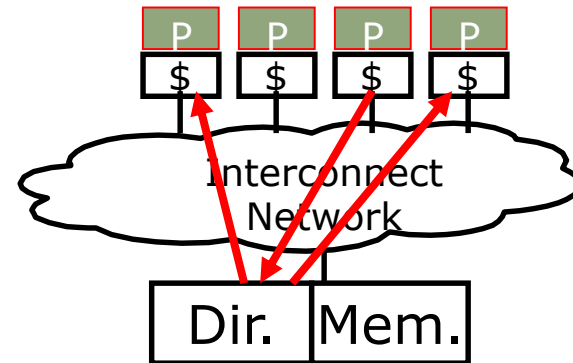

- Directory schemes send messages to only those caches that might have the line
- Can scale to large numbers of processors
- Requires extra directory storage to track possible sharers

An MSI Directory Protocol

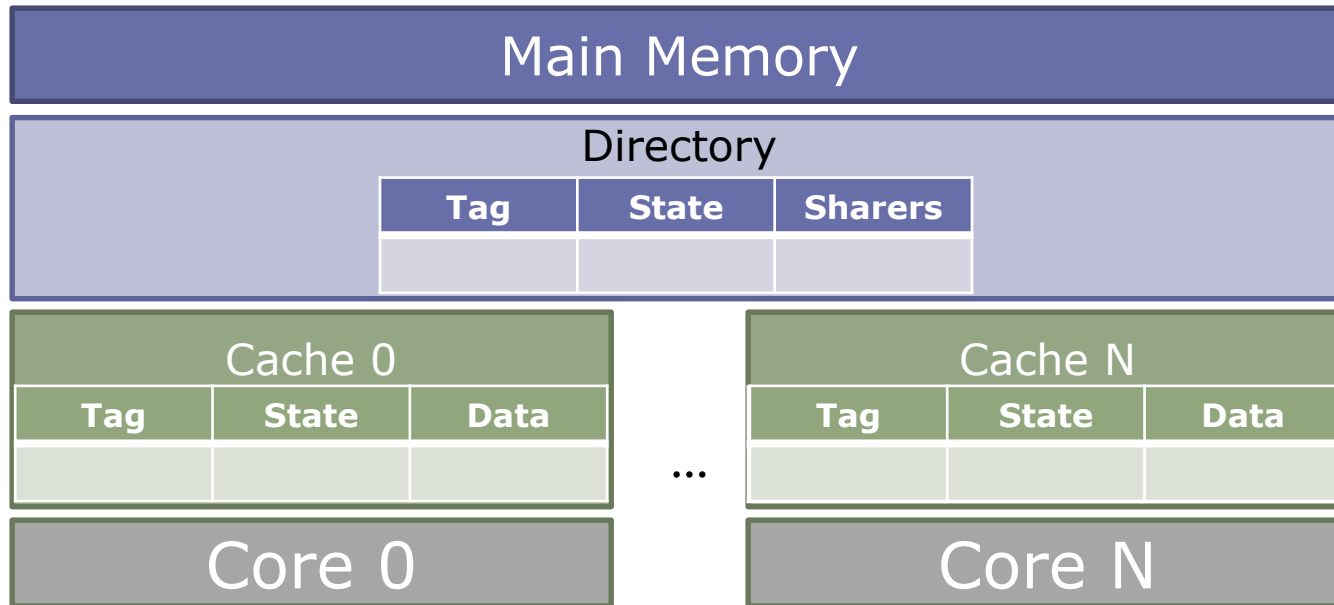

- Cache states: Modified (M) / Shared (S) / Invalid (I)

An MSI Directory Protocol

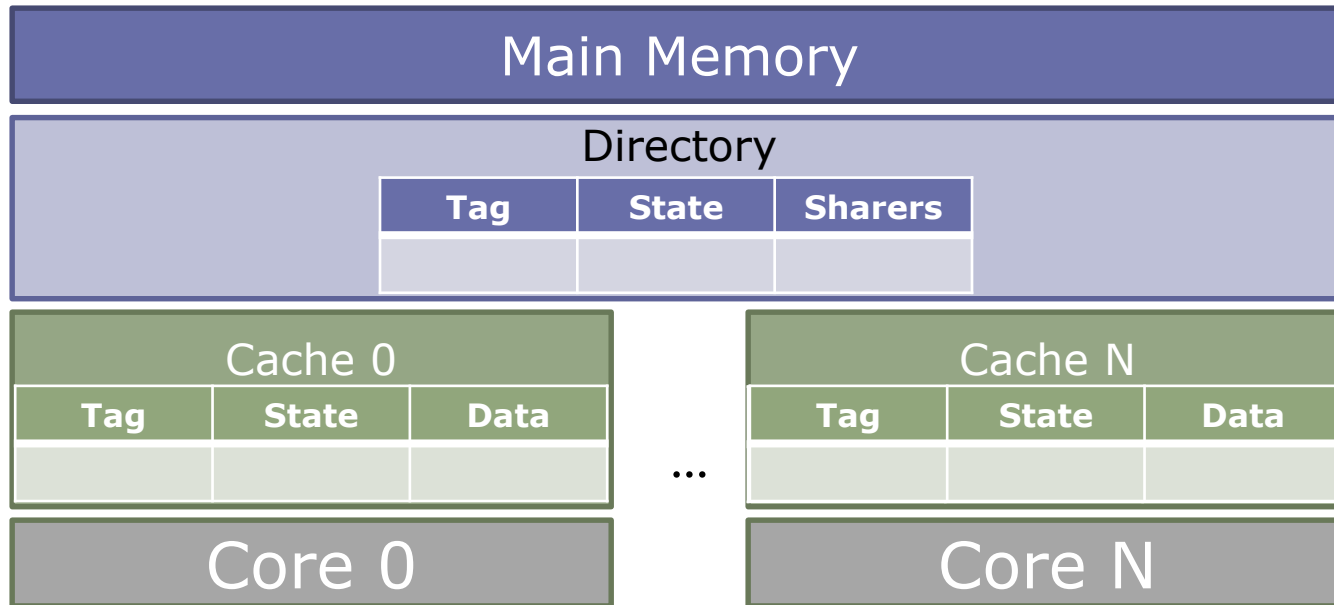

- Cache states: Modified (M) / Shared (S) / Invalid (I)
- Directory states:
 - Uncached (Un): No sharers
 - Shared (Sh): One or more sharers with read permission (S)
 - Exclusive (Ex): A single sharer with read & write permissions (M)

An MSI Directory Protocol

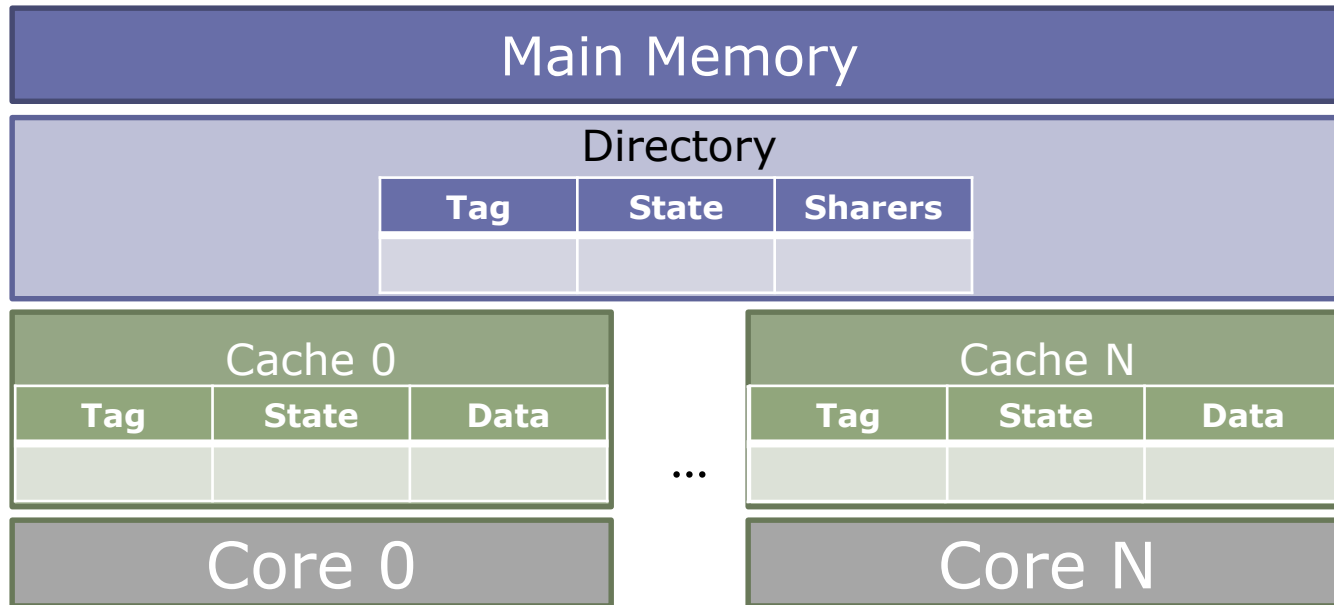

- Cache states: Modified (M) / Shared (S) / Invalid (I)
- Directory states:
 - Uncached (Un): No sharers
 - Shared (Sh): One or more sharers with read permission (S)
 - Exclusive (Ex): A single sharer with read & write permissions (M)
- Transient states not drawn for clarity; for now, assume no racing requests

MSI Protocol: Caches (1/3)

Transitions initiated by processor accesses:

M

S

I

Actions
Processor Read (PrRd)
Processor Write (PrWr)
Shared Request (ShReq)
Exclusive Request (ExReq)

MSI Protocol: Caches (1/3)

Transitions initiated by processor accesses:

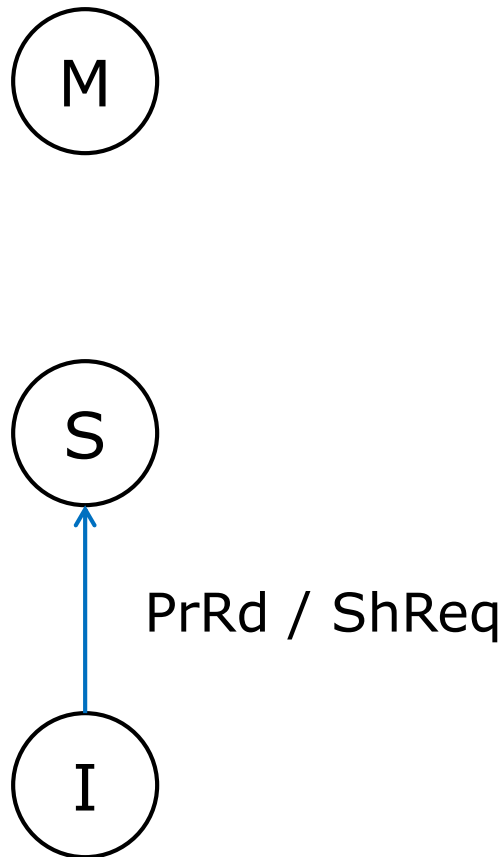

Actions
Processor Read (PrRd)
Processor Write (PrWr)
Shared Request (ShReq)
Exclusive Request (ExReq)

MSI Protocol: Caches (1/3)

Transitions initiated by processor accesses:

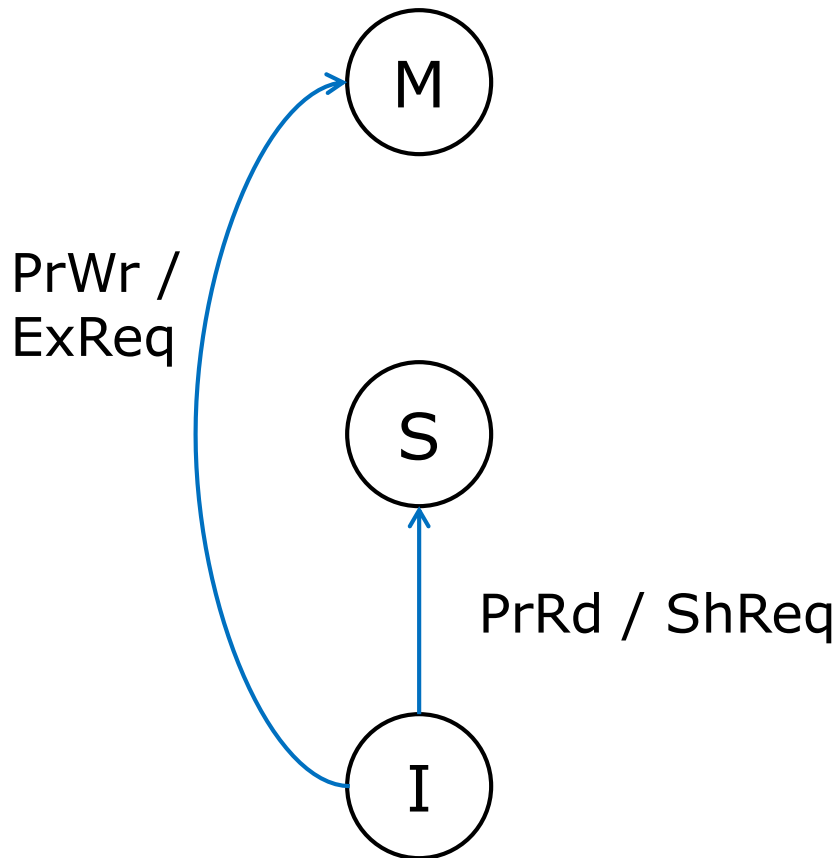

Actions
Processor Read (PrRd)
Processor Write (PrWr)
Shared Request (ShReq)
Exclusive Request (ExReq)

MSI Protocol: Caches (1/3)

Transitions initiated by processor accesses:

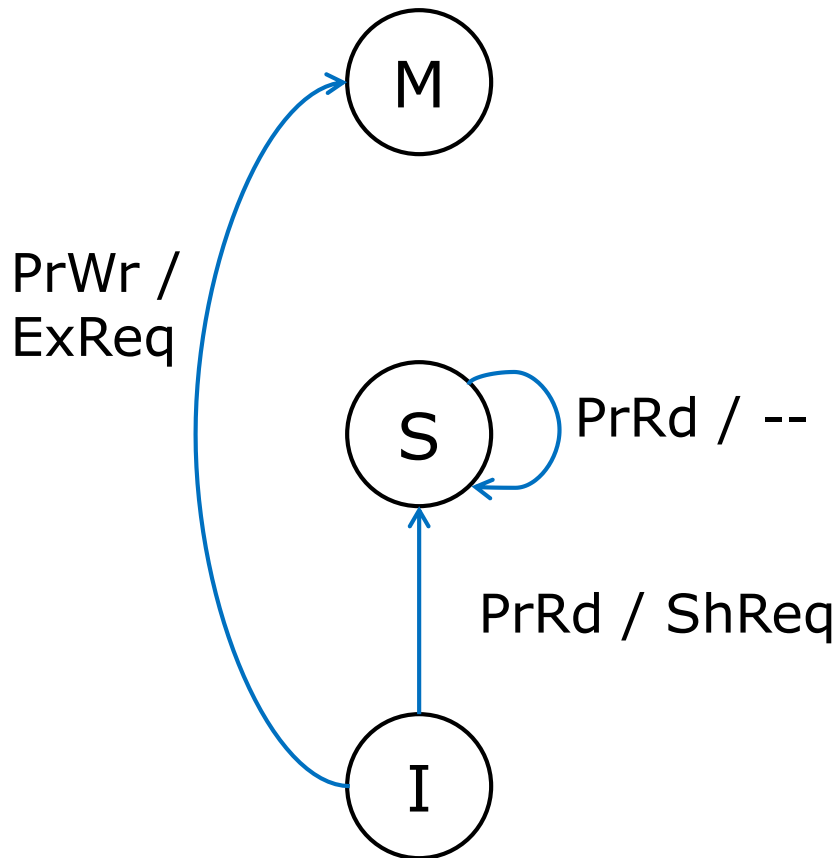

Actions
Processor Read (PrRd)
Processor Write (PrWr)
Shared Request (ShReq)
Exclusive Request (ExReq)

MSI Protocol: Caches (1/3)

Transitions initiated by processor accesses:

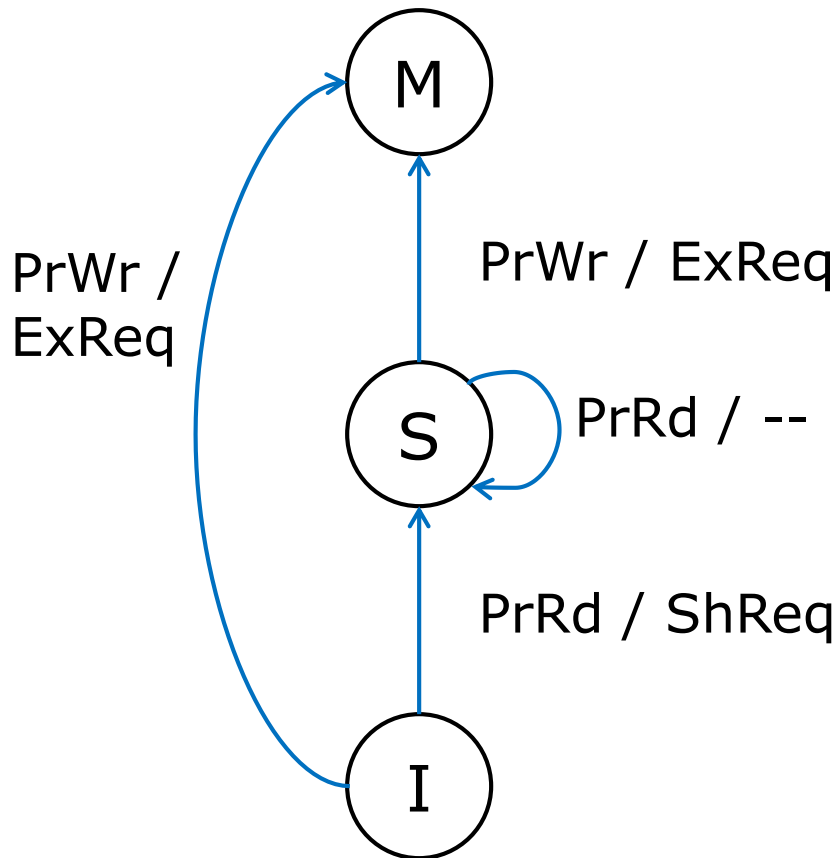

Actions
Processor Read (PrRd)
Processor Write (PrWr)
Shared Request (ShReq)
Exclusive Request (ExReq)

MSI Protocol: Caches (1/3)

Transitions initiated by processor accesses:

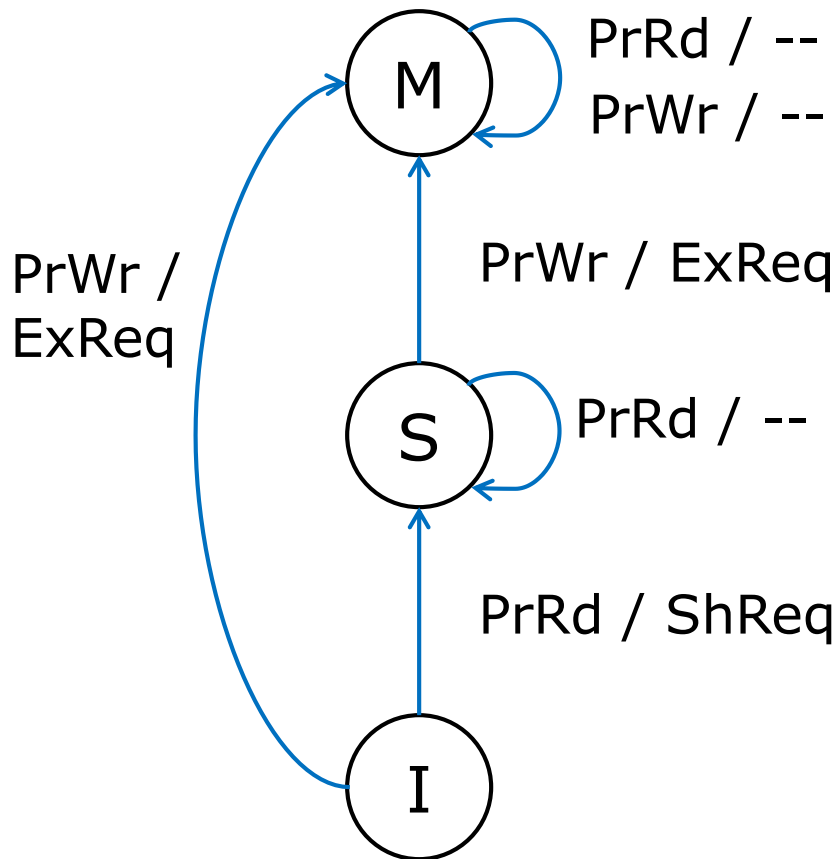

Actions
Processor Read (PrRd)
Processor Write (PrWr)
Shared Request (ShReq)
Exclusive Request (ExReq)

MSI Protocol: Caches (2/3)

Transitions initiated by directory requests:

M

S

I

Actions
Invalidation Request (InvReq)
Downgrade Request (DownReq)
Invalidation Response (InvResp)
Downgrade Response (DownResp)

MSI Protocol: Caches (2/3)

Transitions initiated by directory requests:

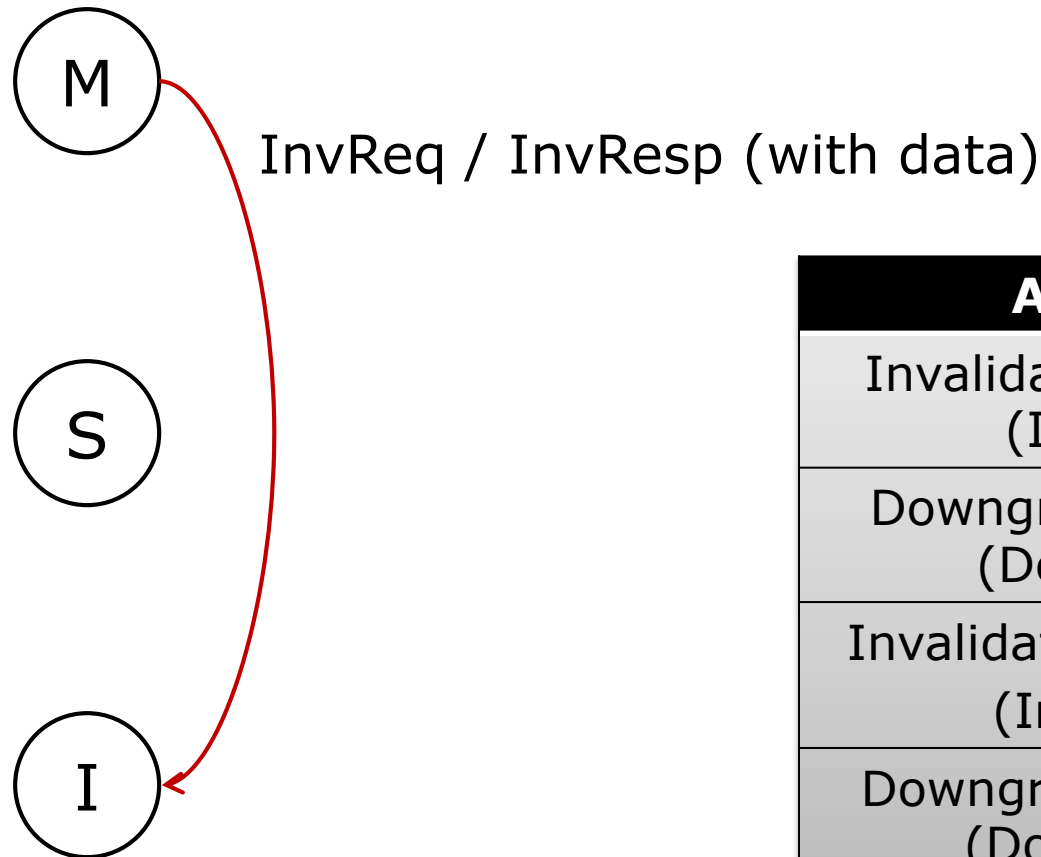

Actions
Invalidation Request (InvReq)
Downgrade Request (DownReq)
Invalidation Response (InvResp)
Downgrade Response (DownResp)

MSI Protocol: Caches (2/3)

Transitions initiated by directory requests:

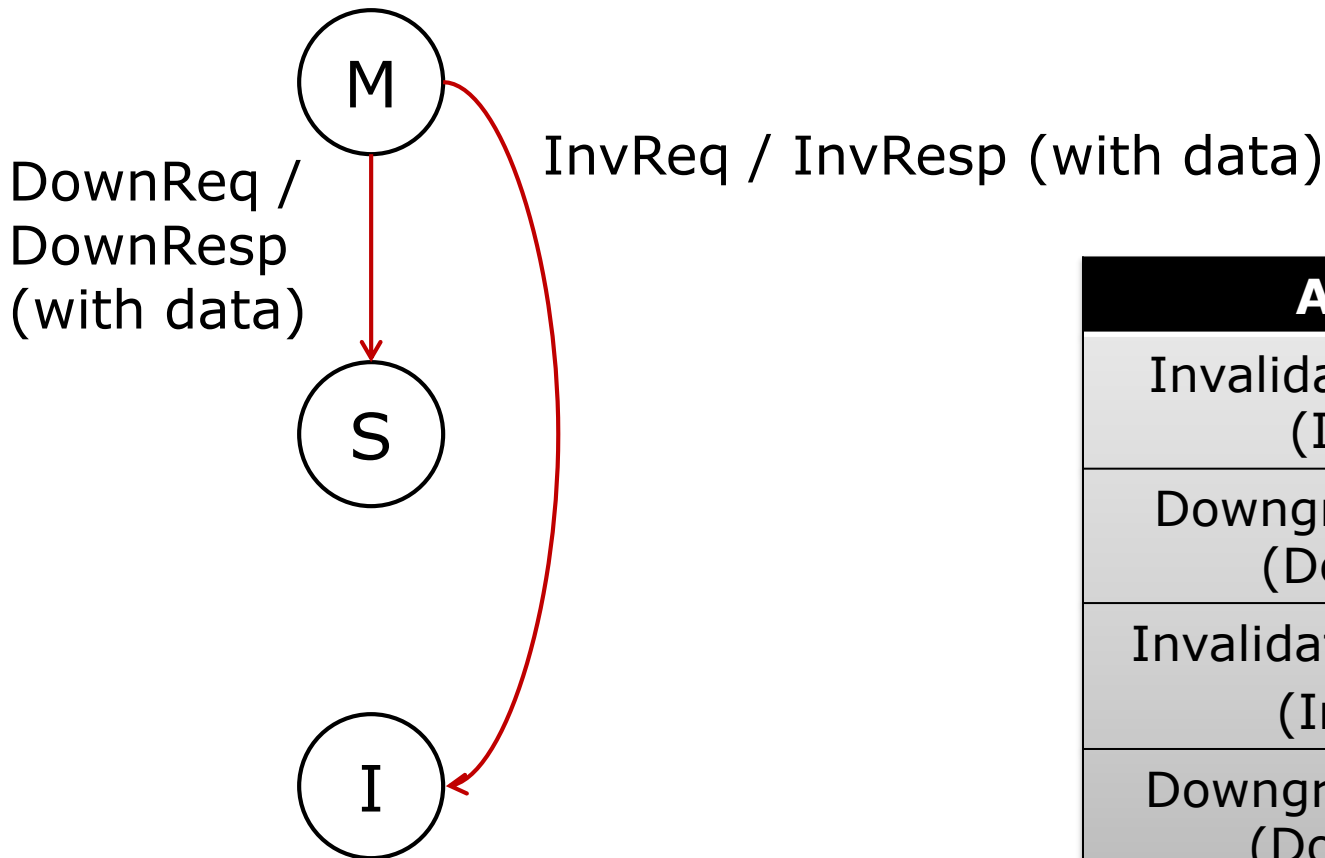

Actions
Invalidation Request (InvReq)
Downgrade Request (DownReq)
Invalidation Response (InvResp)
Downgrade Response (DownResp)

MSI Protocol: Caches (2/3)

Transitions initiated by directory requests:

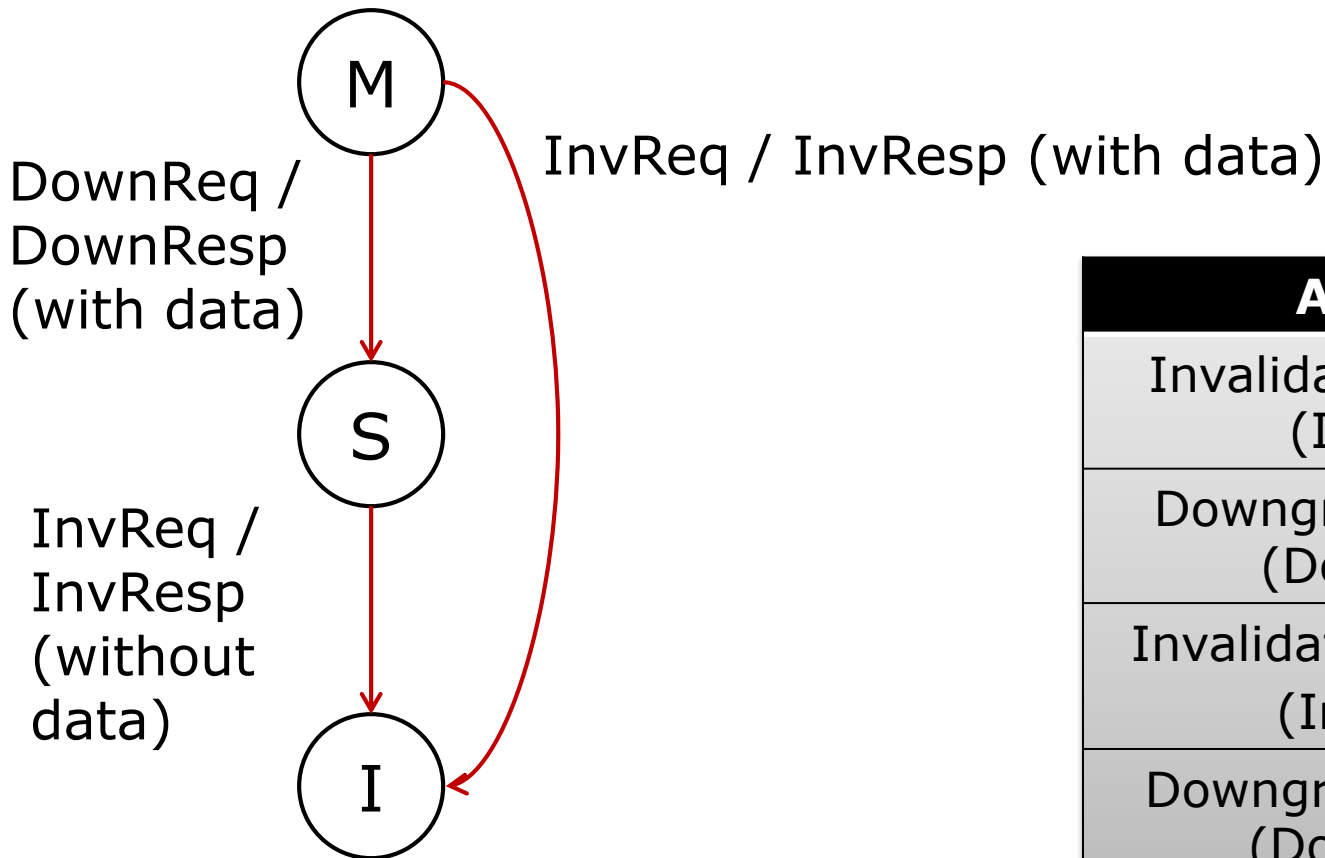

Actions
Invalidation Request (InvReq)
Downgrade Request (DownReq)
Invalidation Response (InvResp)
Downgrade Response (DownResp)

MSI Protocol: Caches (3/3)

Transitions initiated by evictions:

M

S

I

Actions
Writeback Request (WbReq)

MSI Protocol: Caches (3/3)

Transitions initiated by evictions:

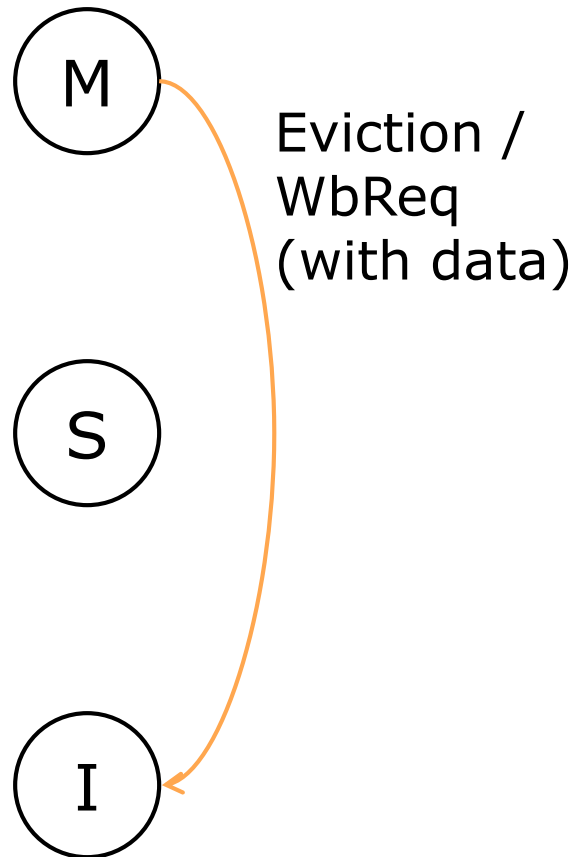

Actions
Writeback Request (WbReq)

MSI Protocol: Caches (3/3)

Transitions initiated by evictions:

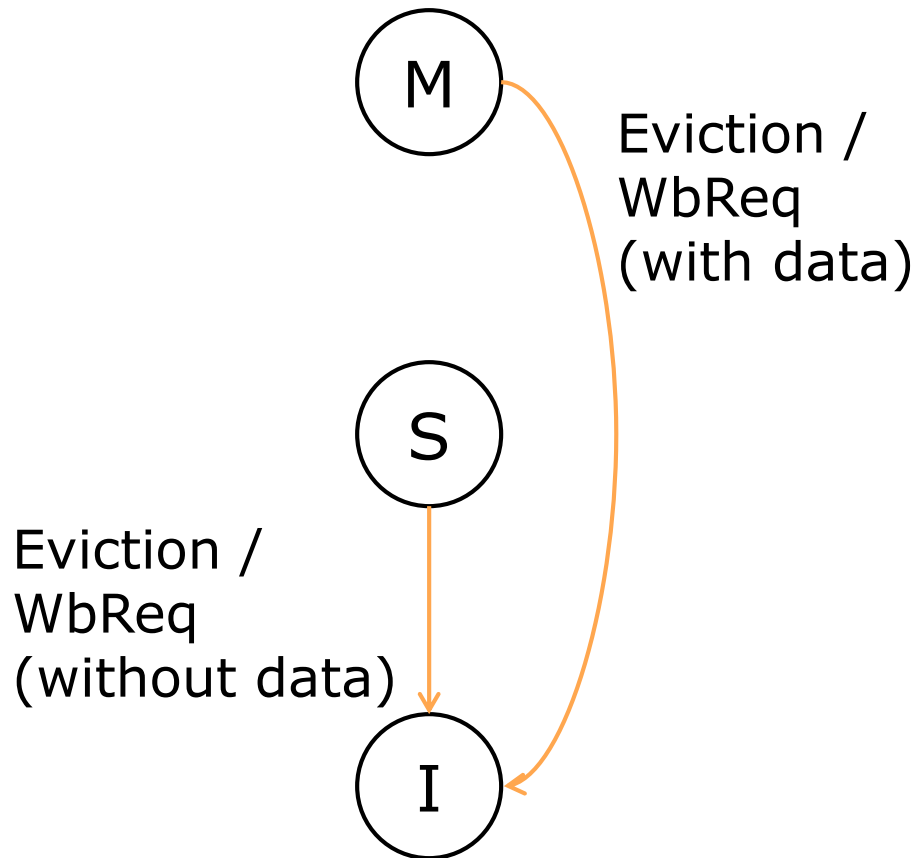

Actions
Writeback Request (WbReq)

MSI Protocol: Caches

- Transitions initiated by processor accesses
- Transitions initiated by directory requests
- Transitions initiated by evictions

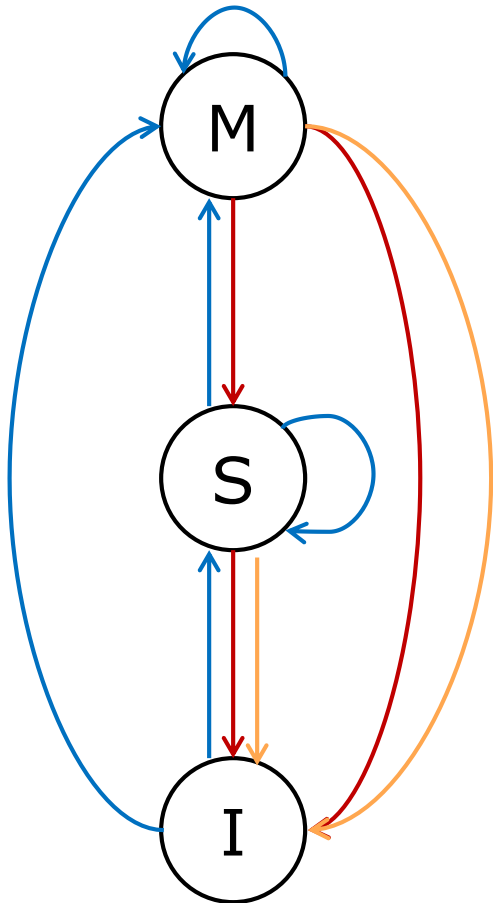

MSI Protocol: Directory (1/2)

Transitions initiated by data requests:

Ex

Sh

Un

MSI Protocol: Directory (1/2)

Transitions initiated by data requests:

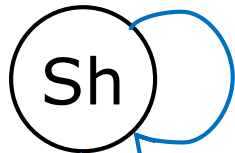

ShReq / Sharers = Sharers + {P}; ShResp

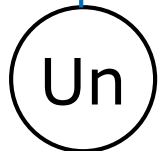

ShReq / Sharers = {P}; ShResp

MSI Protocol: Directory (1/2)

Transitions initiated by data requests:

ExReq / Sharers = {P}; ExResp

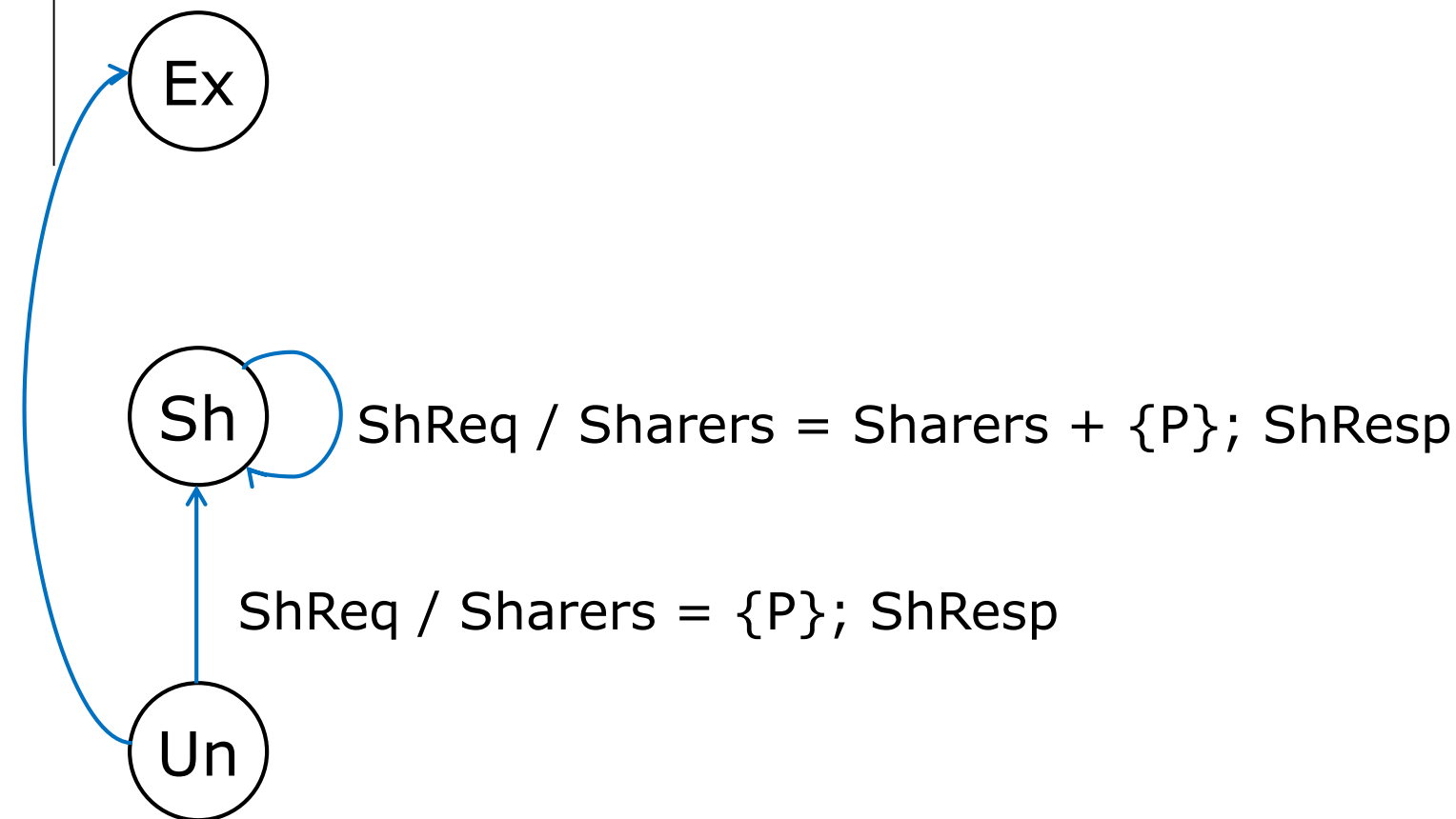

MSI Protocol: Directory (1/2)

Transitions initiated by data requests:

ExReq / Sharers = {P}; ExResp

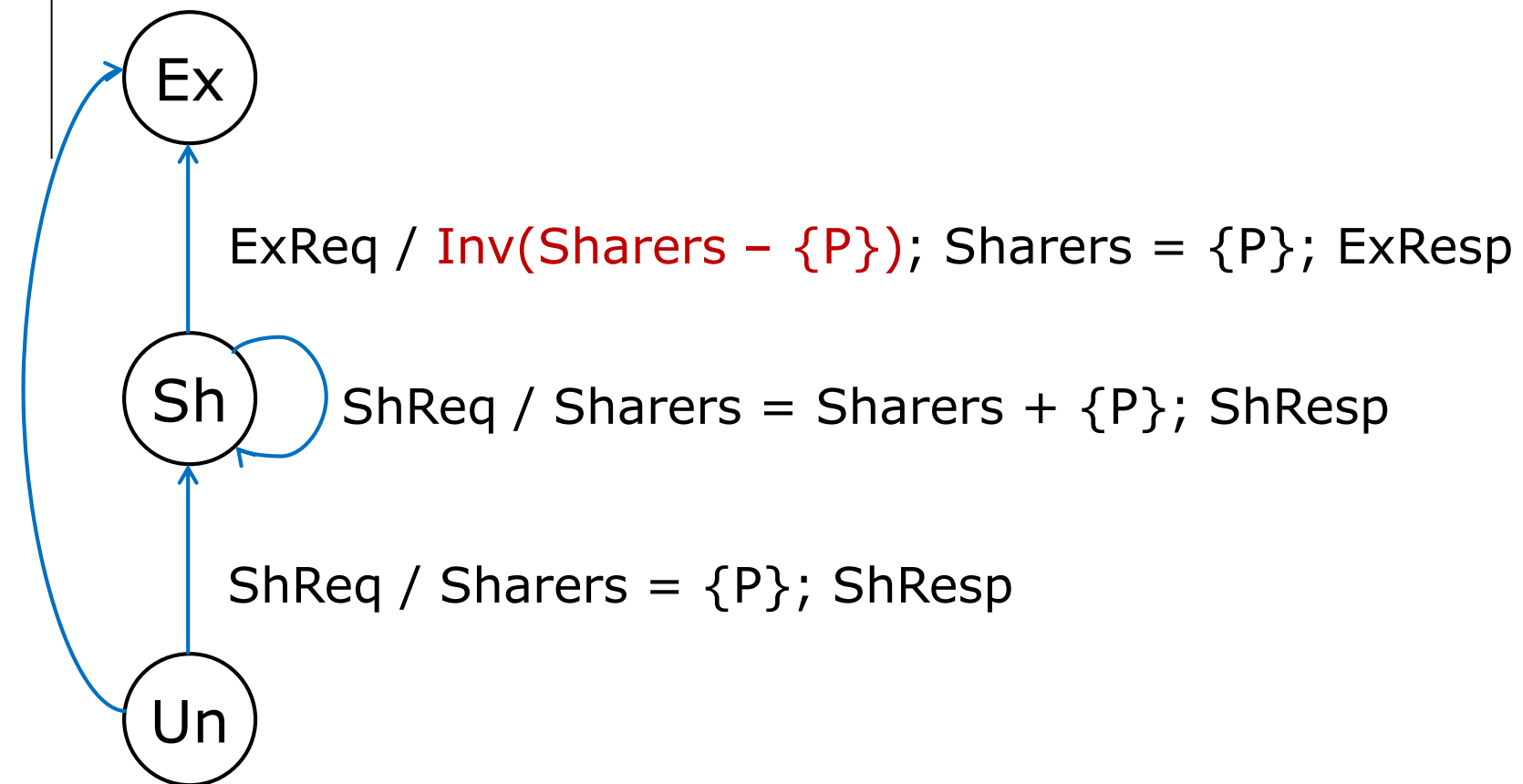

MSI Protocol: Directory (1/2)

Transitions initiated by data requests:

ExReq / Sharers = {P}; ExResp

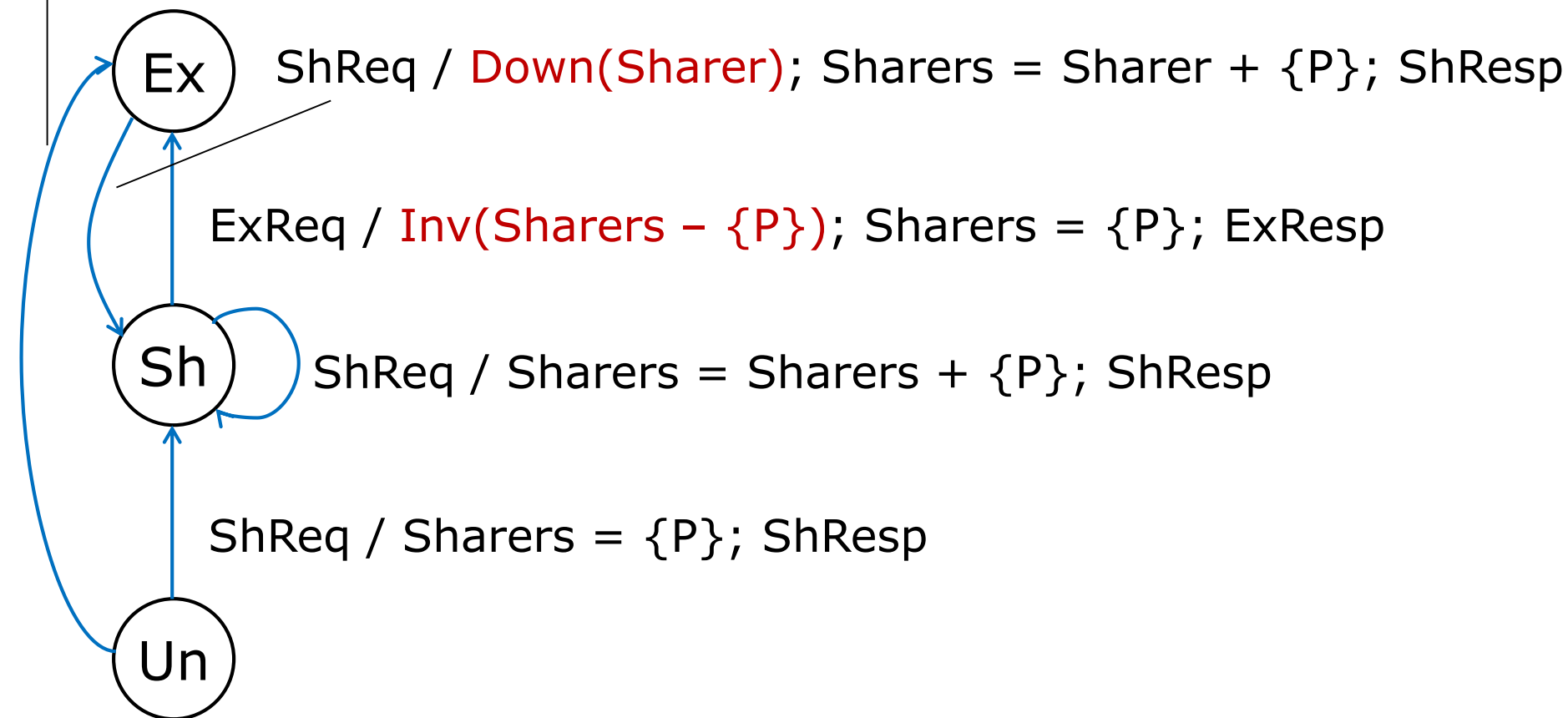

MSI Protocol: Directory (2/2)

Transitions initiated by writeback requests:

Ex

Sh

Un

MSI Protocol: Directory (2/2)

Transitions initiated by writeback requests:

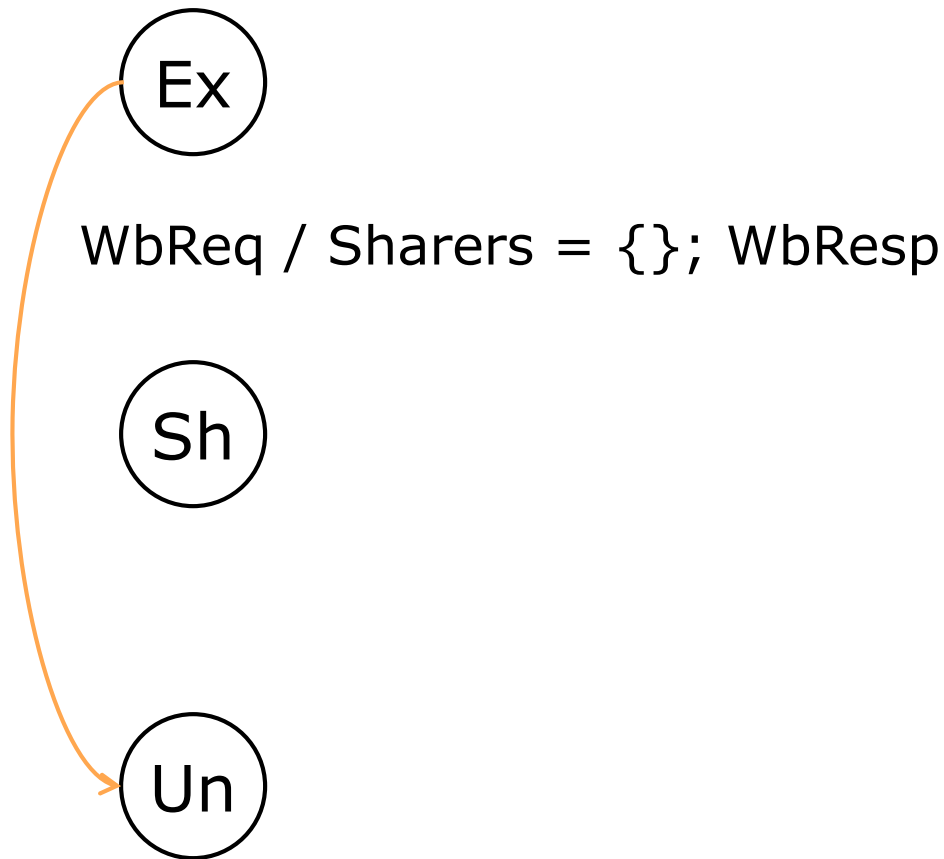

MSI Protocol: Directory (2/2)

Transitions initiated by writeback requests:

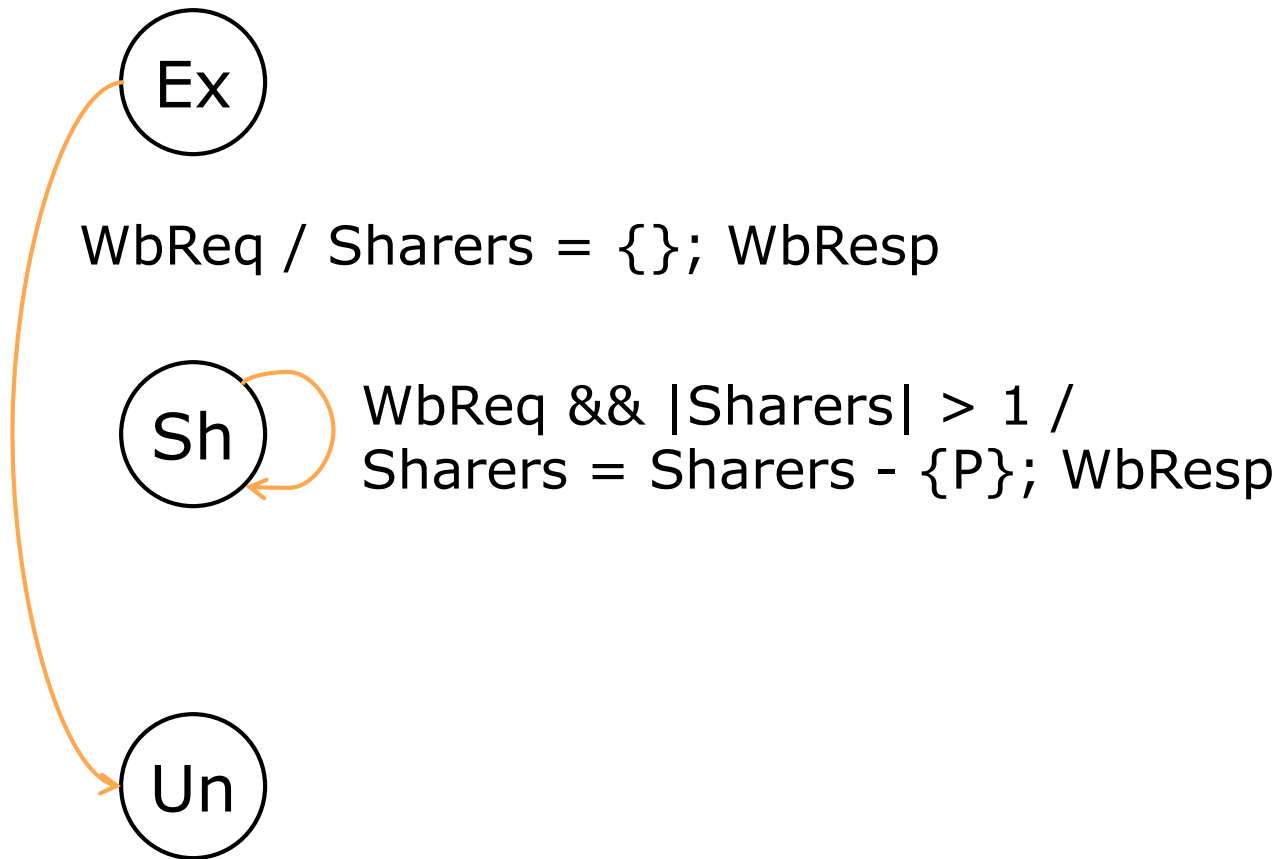

MSI Protocol: Directory (2/2)

Transitions initiated by writeback requests:

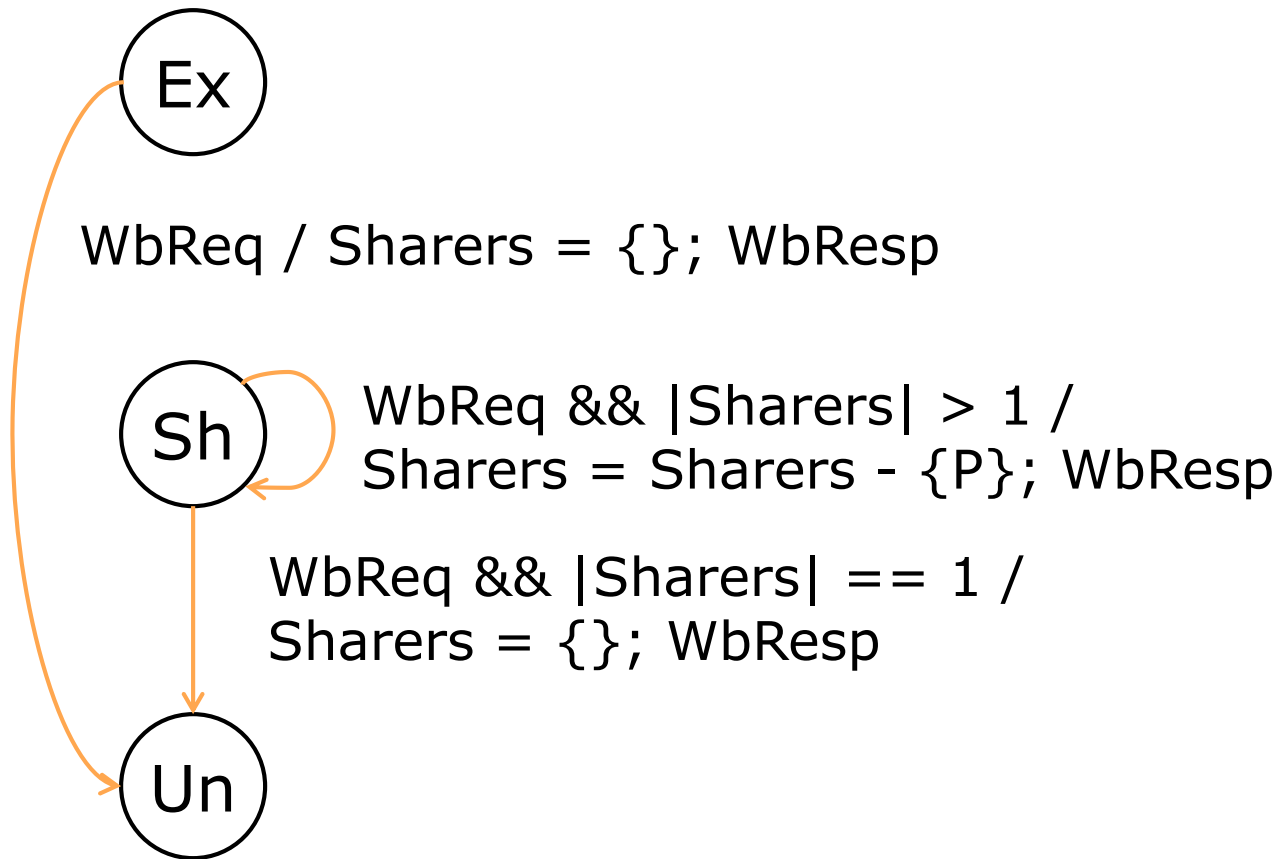

MSI Directory Protocol Example

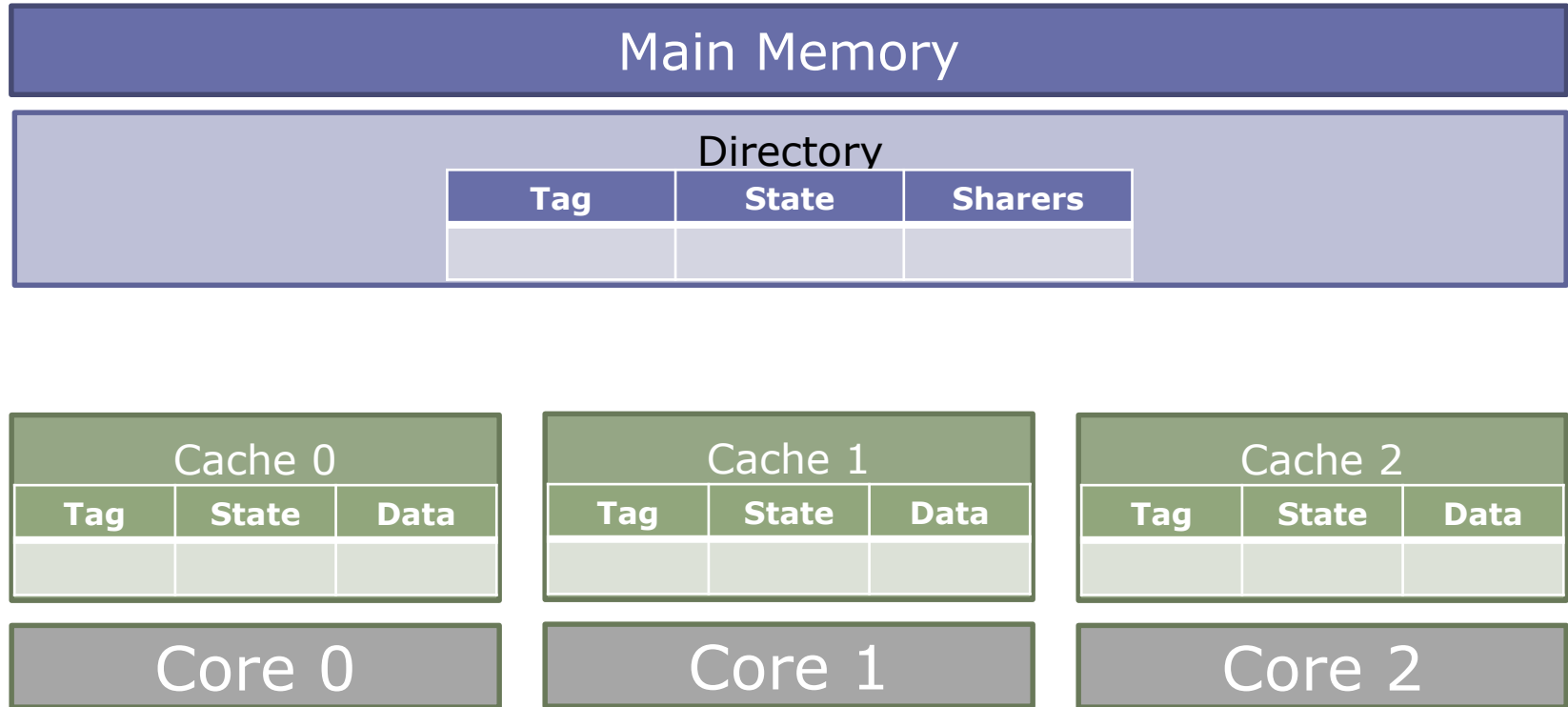

MSI Directory Protocol Example

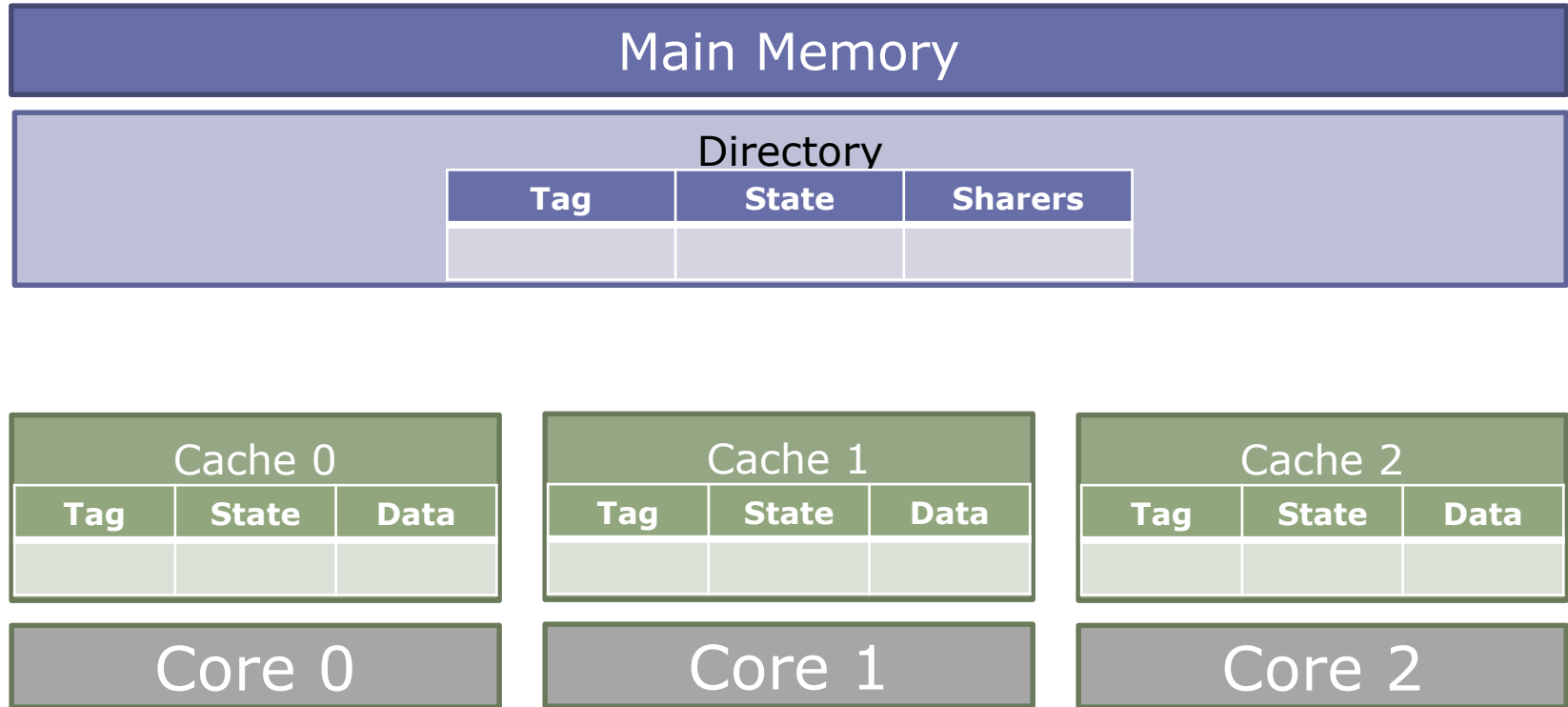

1 LD 0xA

MSI Directory Protocol Example

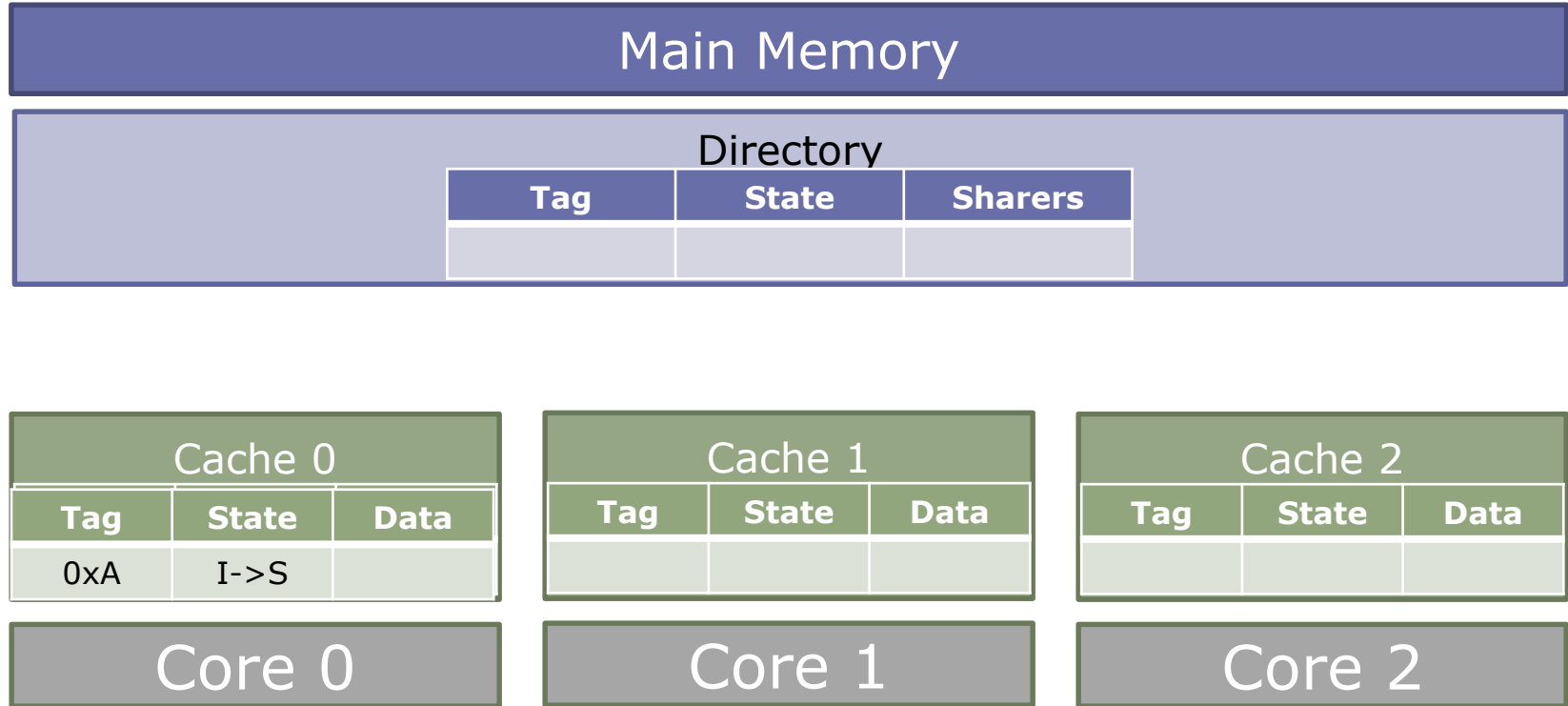

1 LD 0xA

MSI Directory Protocol Example



2 ShReq 0xA

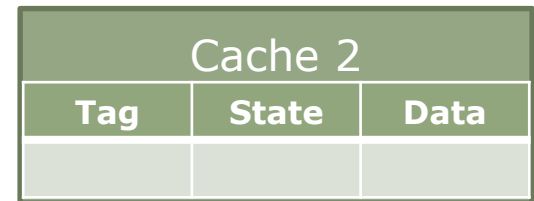
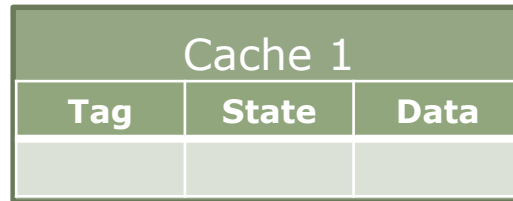
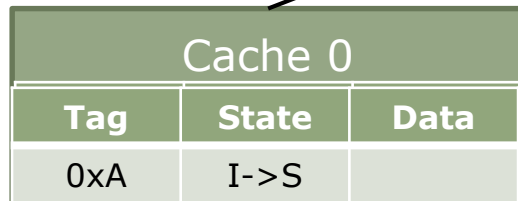

1 LD 0xA

MSI Directory Protocol Example

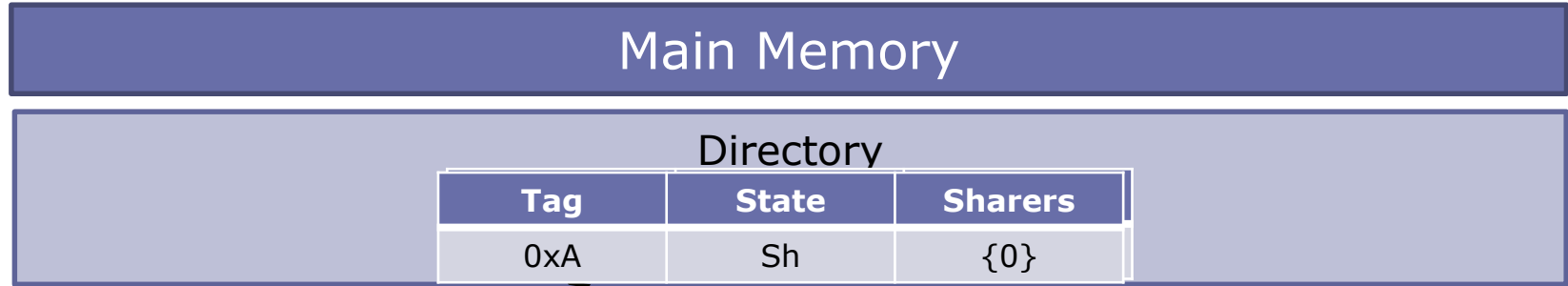

2 ShReq 0xA

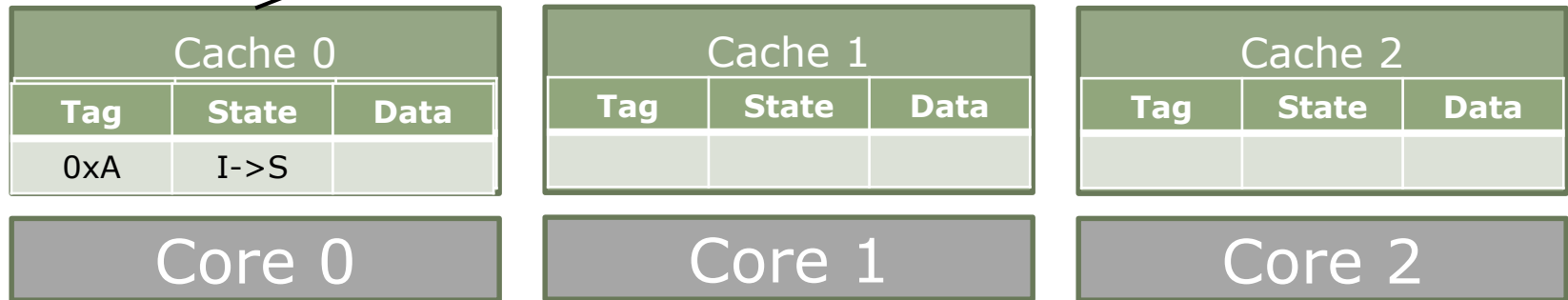

1 LD 0xA

MSI Directory Protocol Example

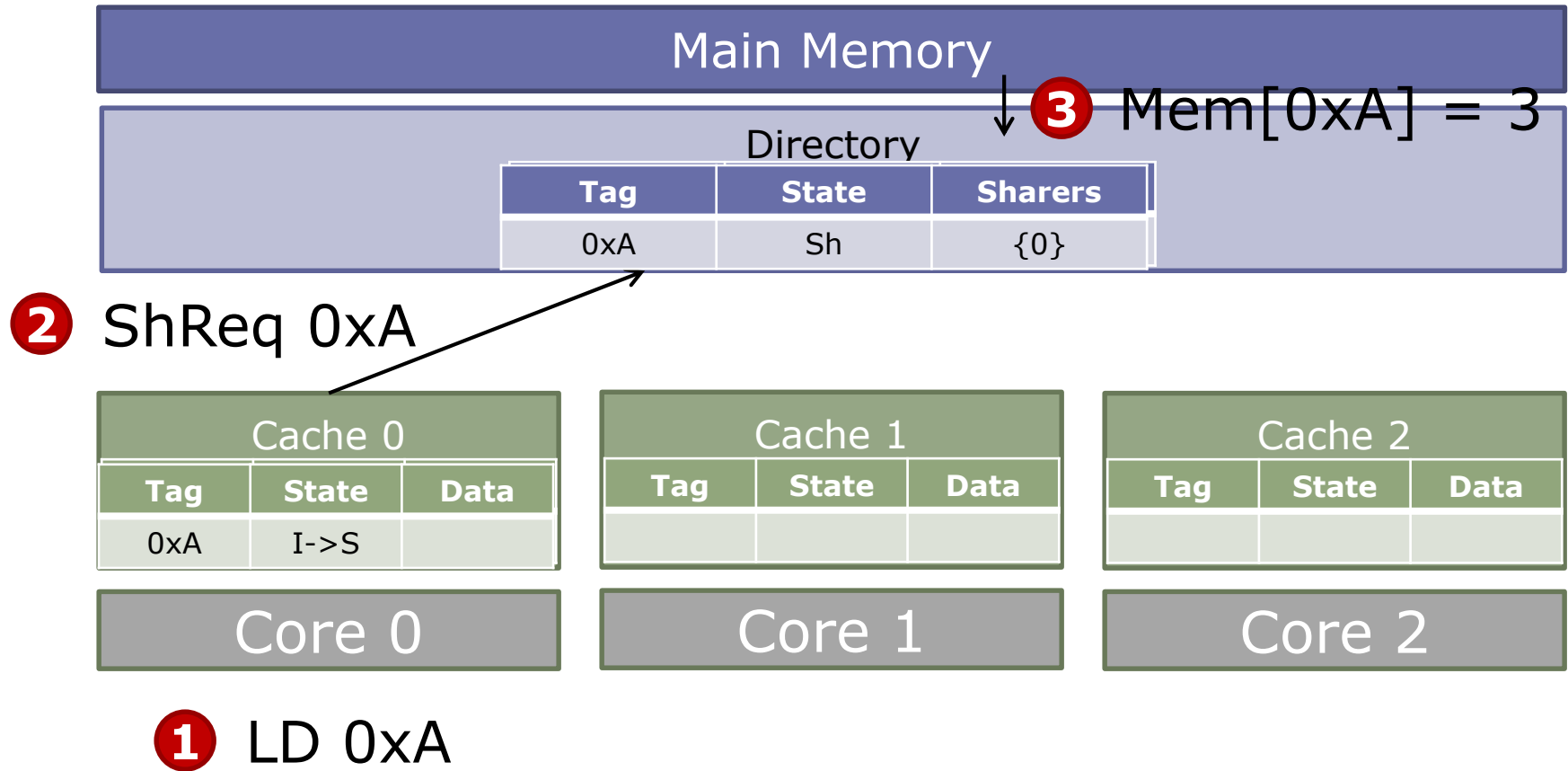

MSI Directory Protocol Example

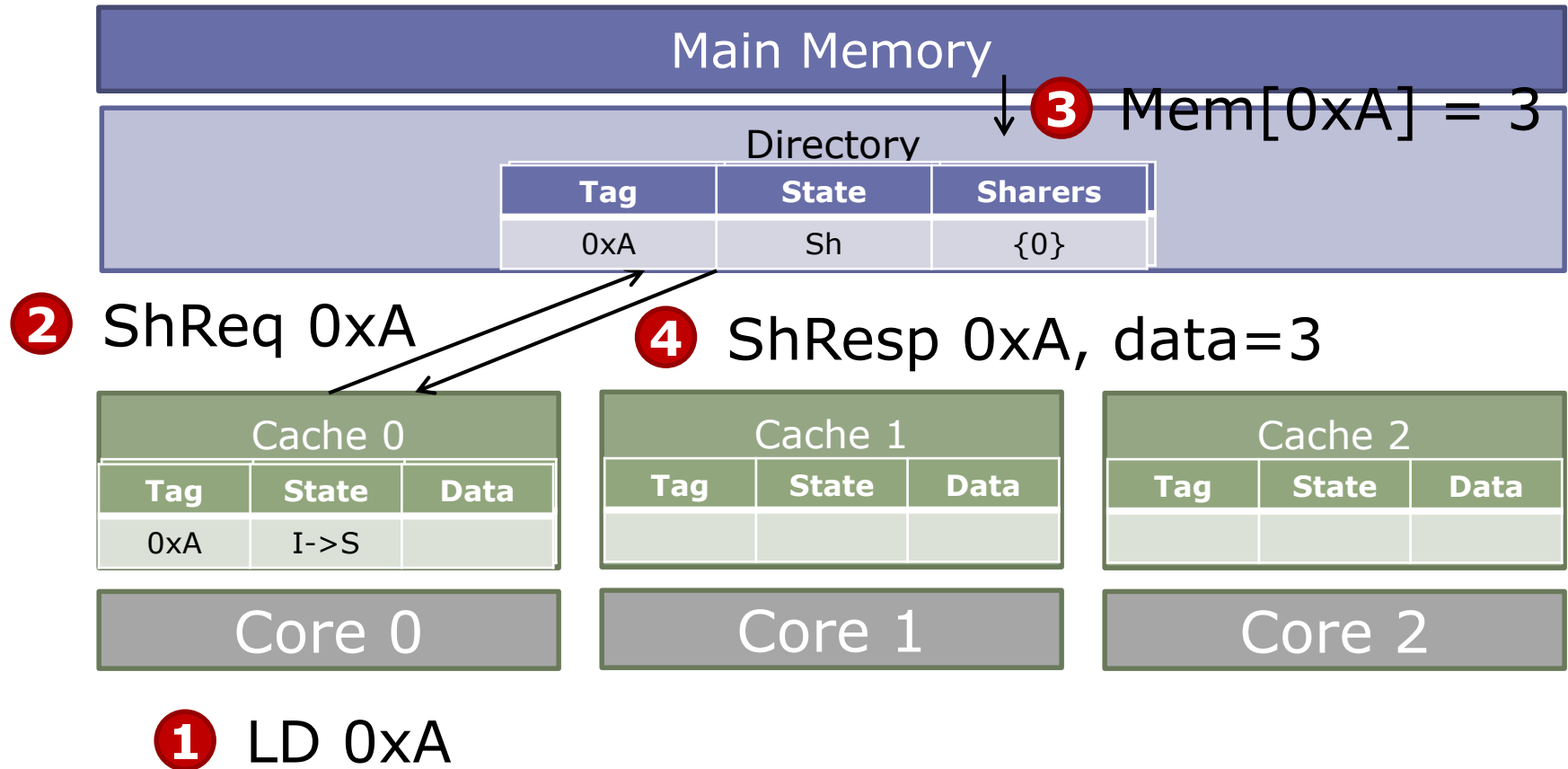

MSI Directory Protocol Example

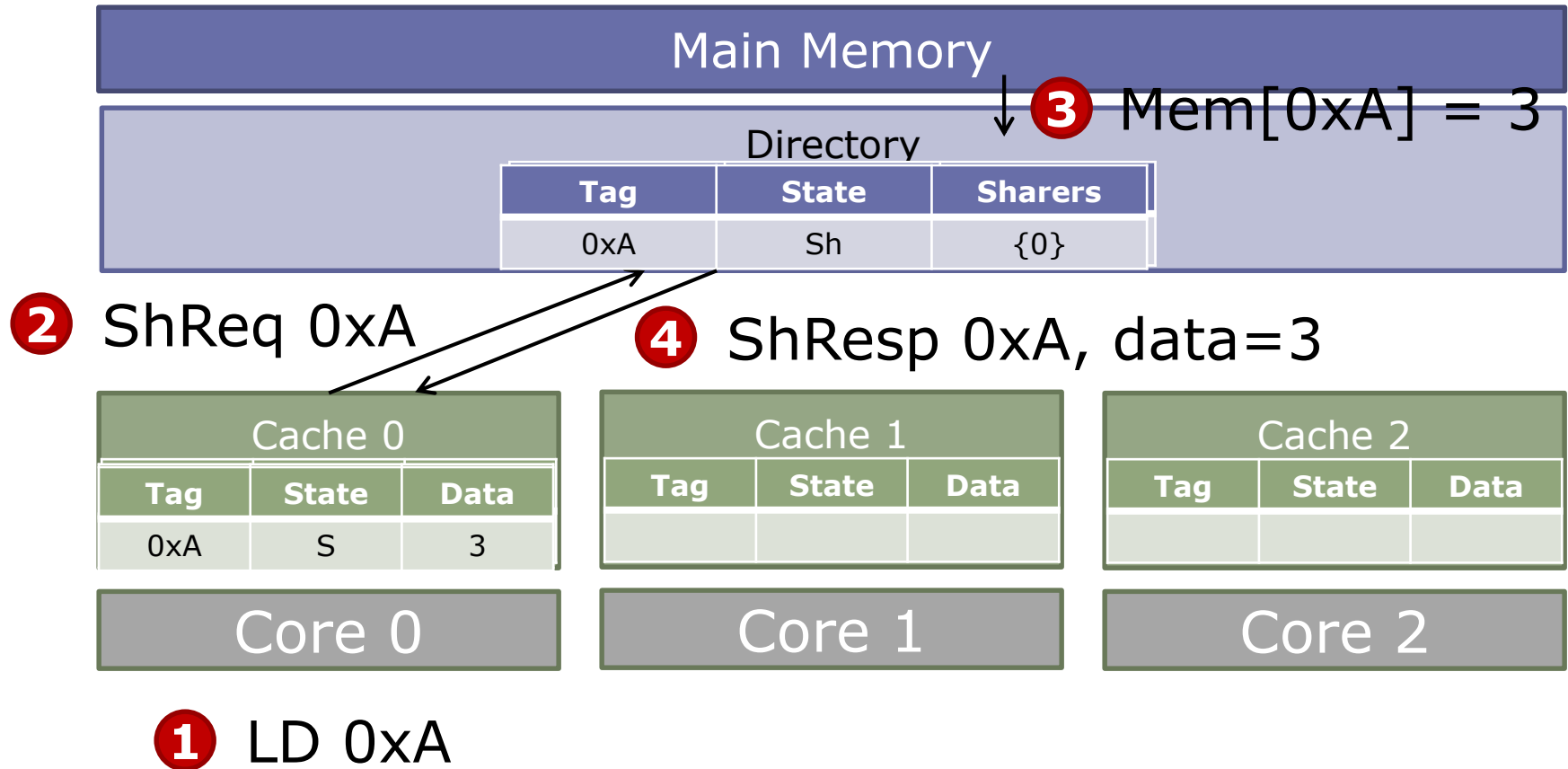

MSI Directory Protocol Example

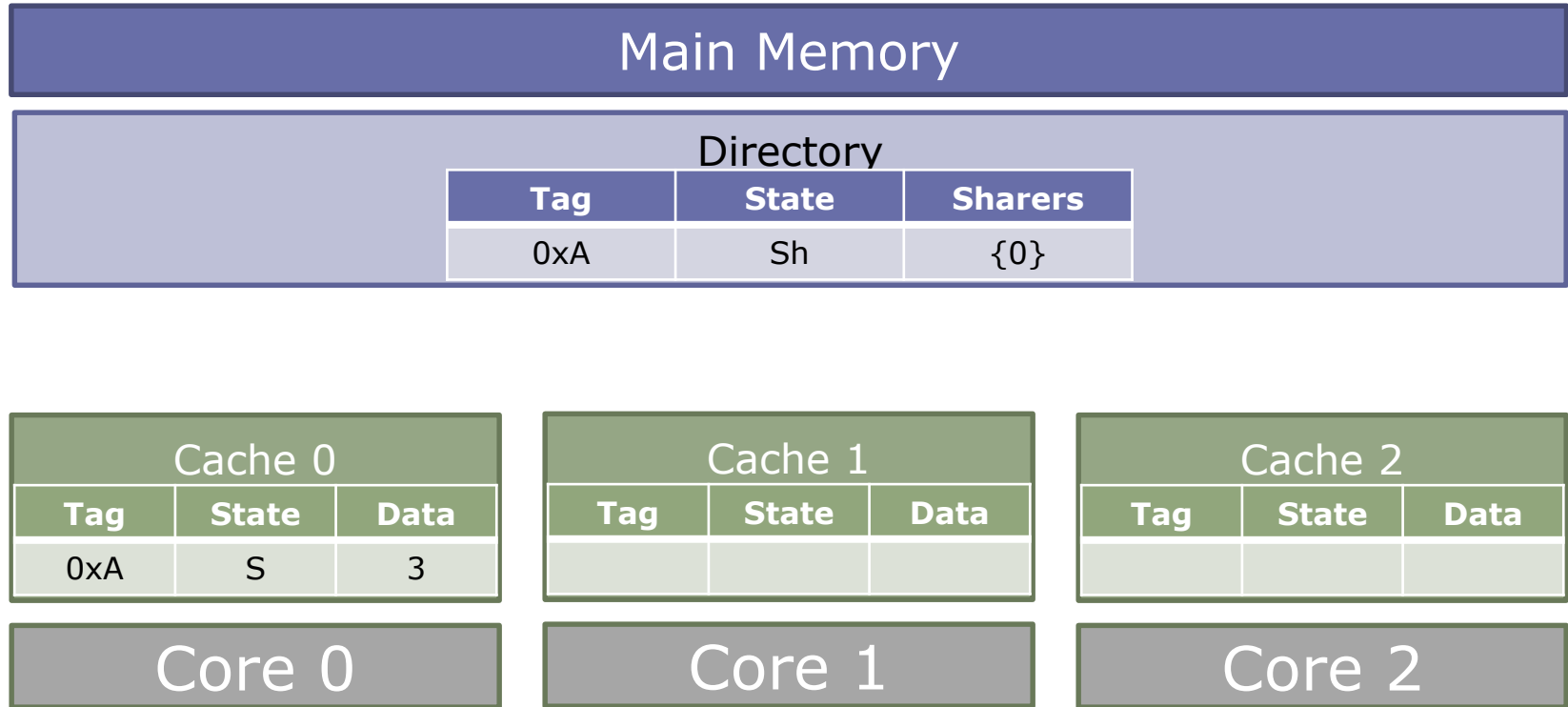

MSI Directory Protocol Example

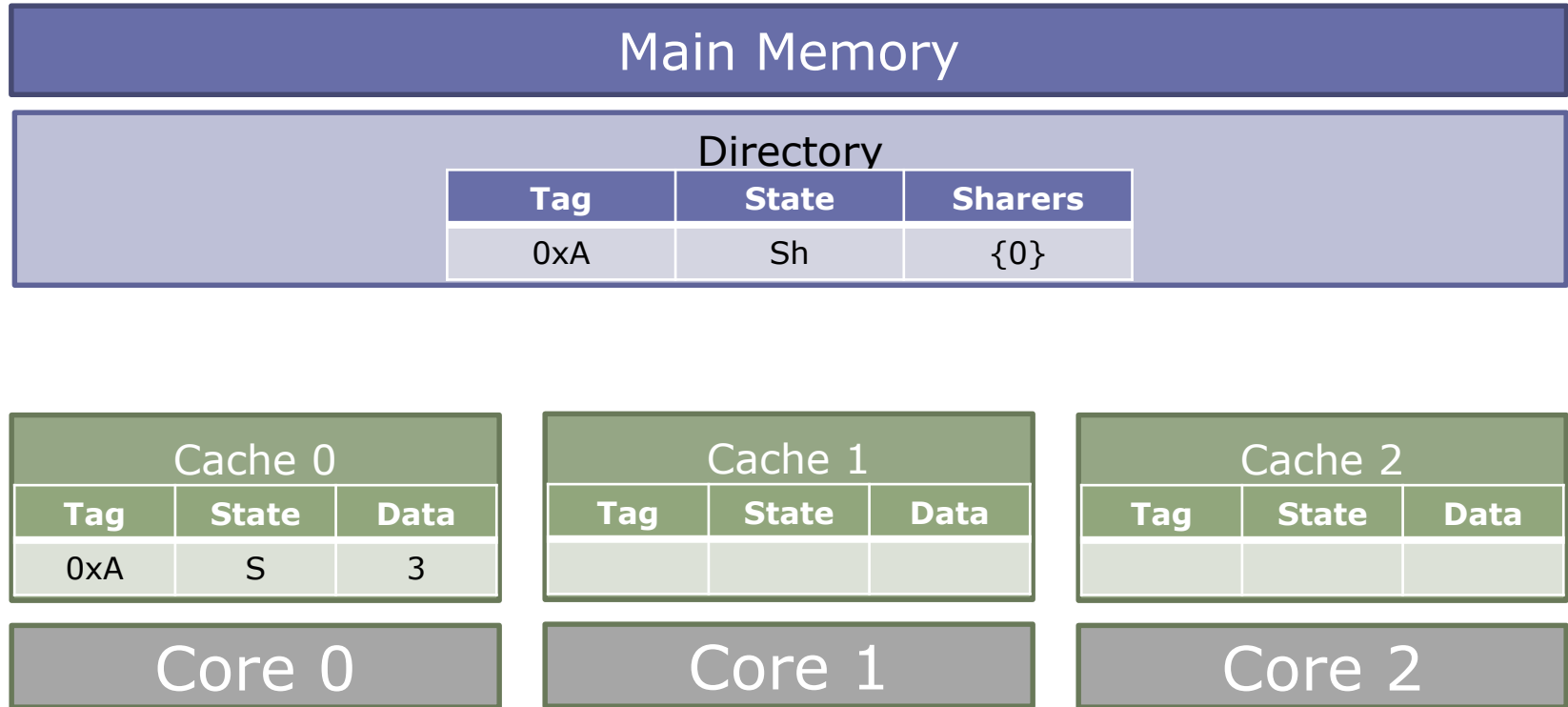

1 LD 0xA

MSI Directory Protocol Example

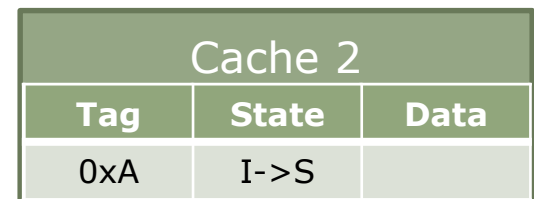
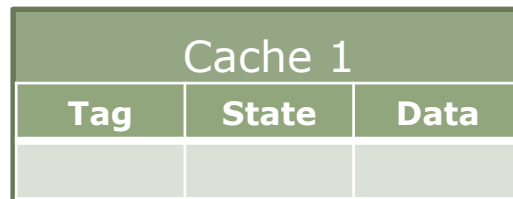
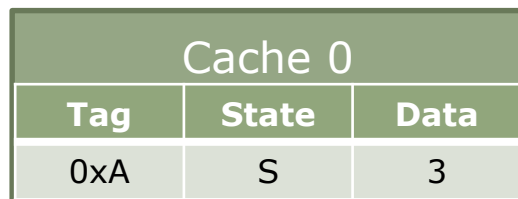
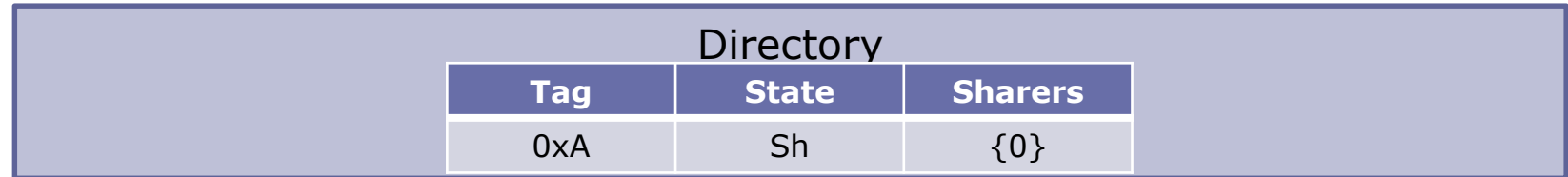

1 LD 0xA

MSI Directory Protocol Example

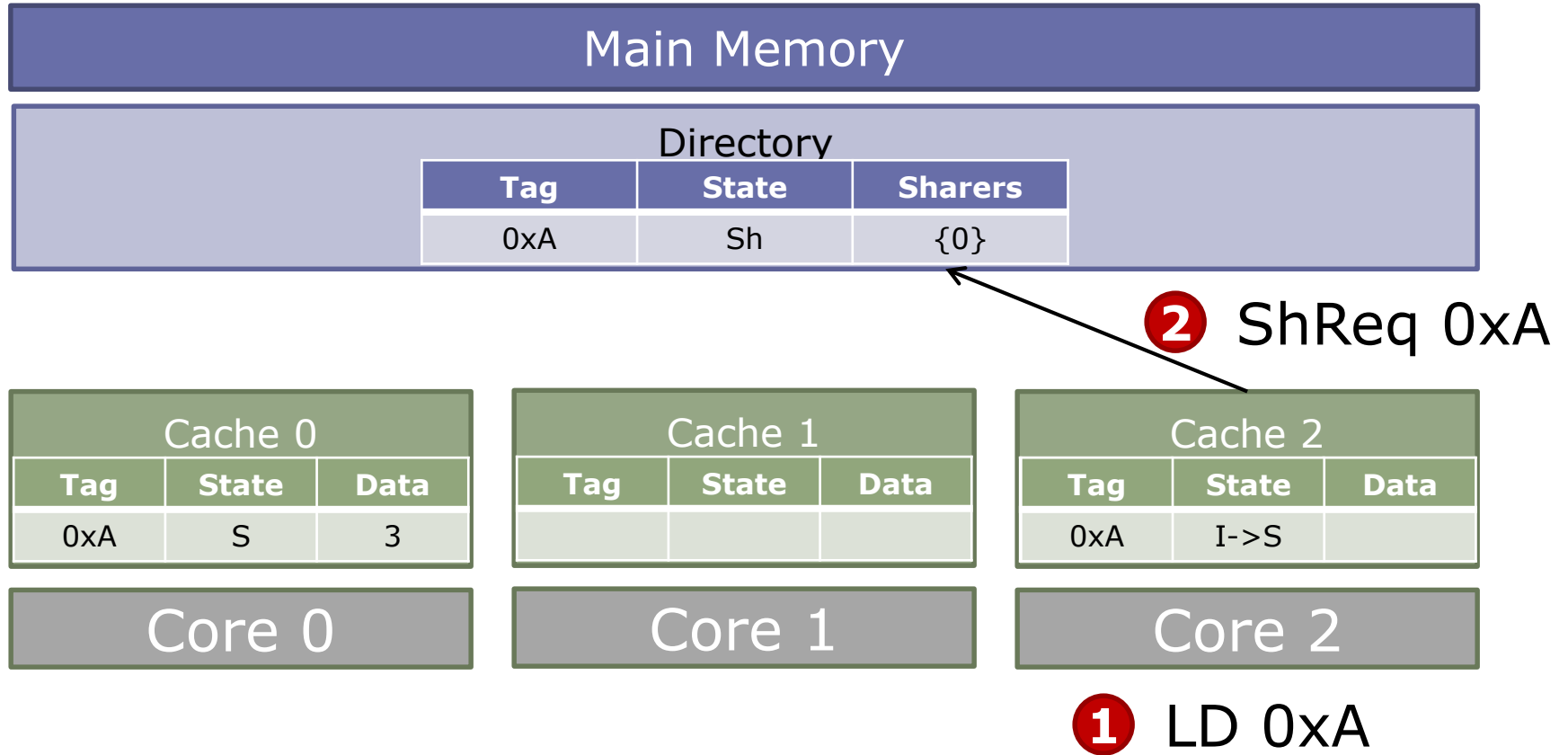

MSI Directory Protocol Example

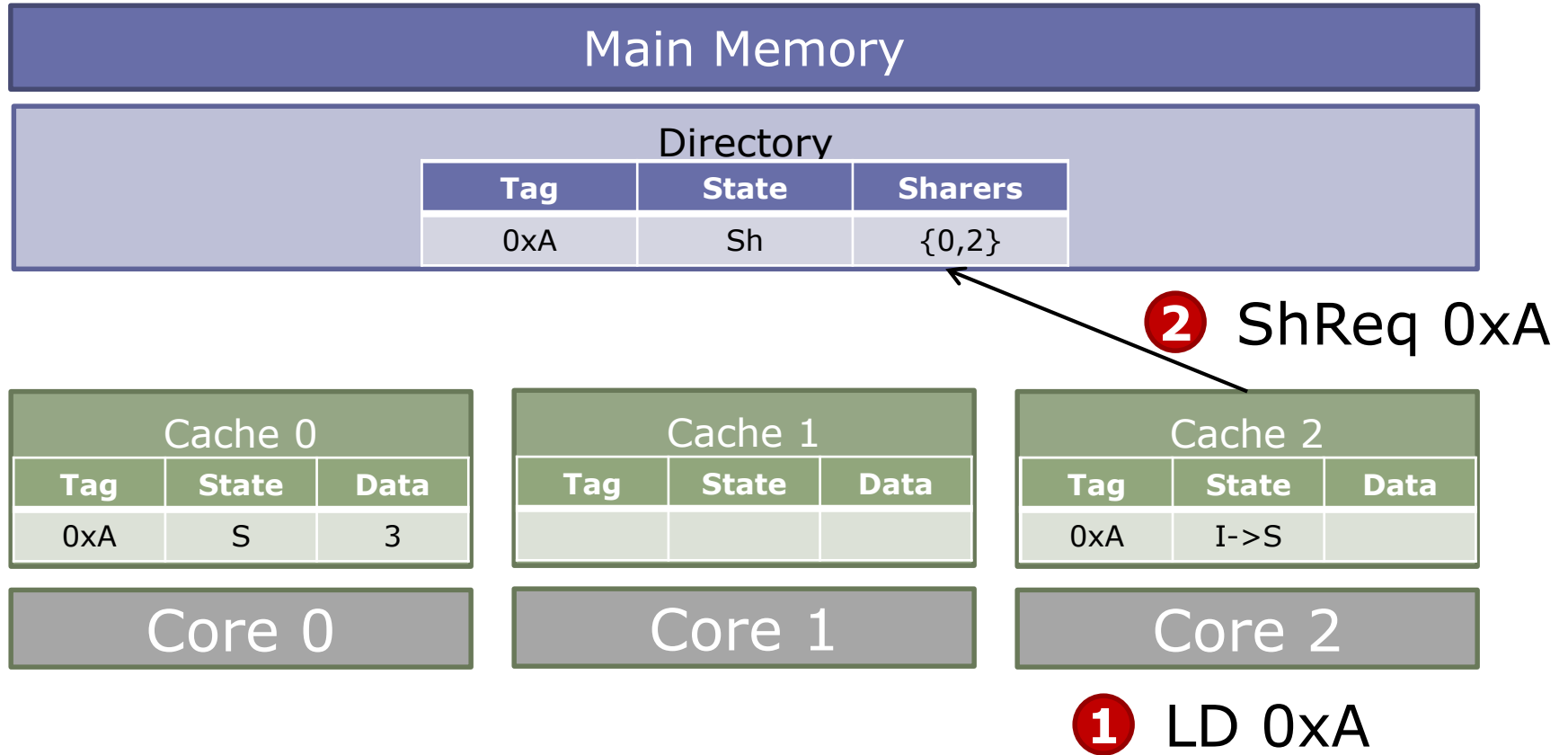

MSI Directory Protocol Example

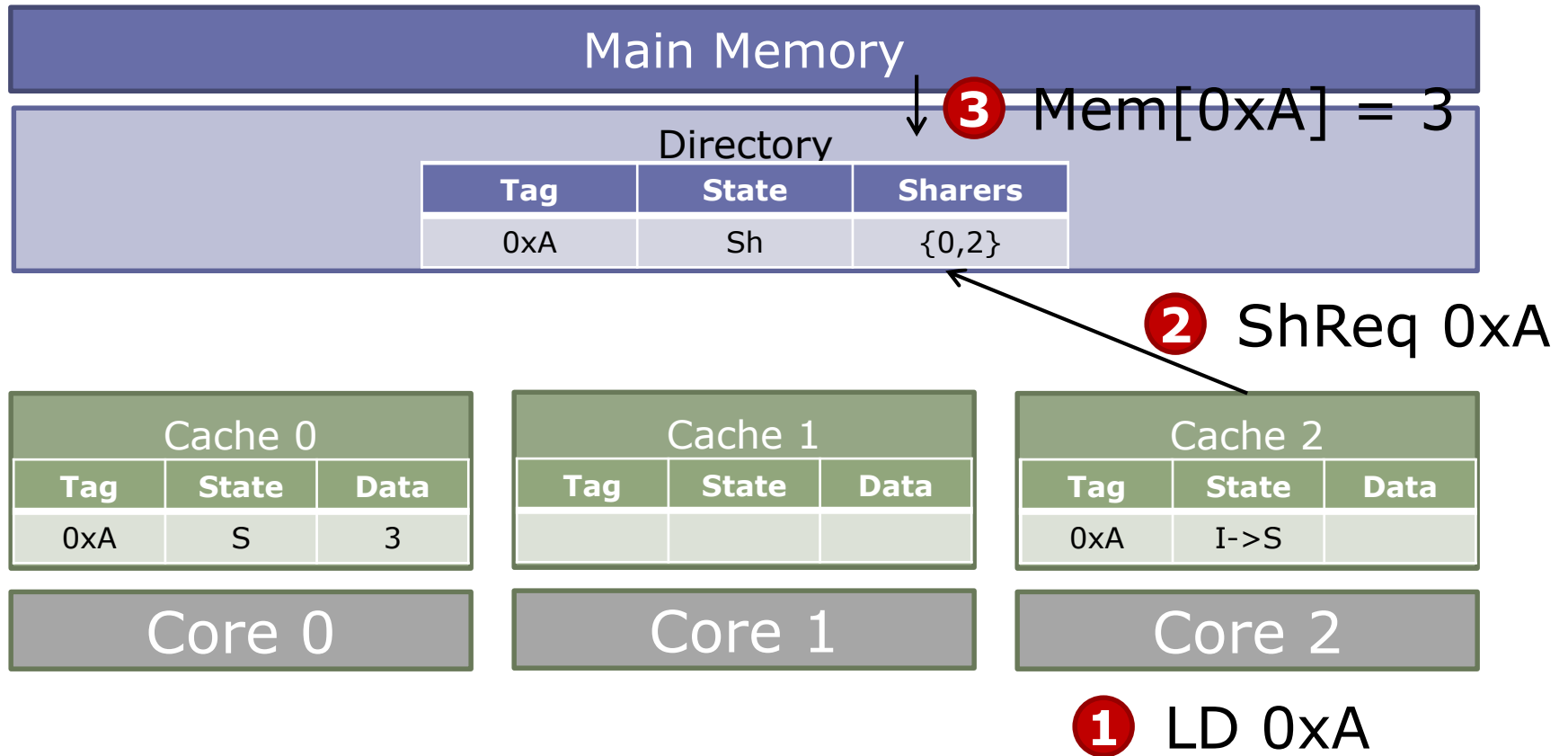

MSI Directory Protocol Example

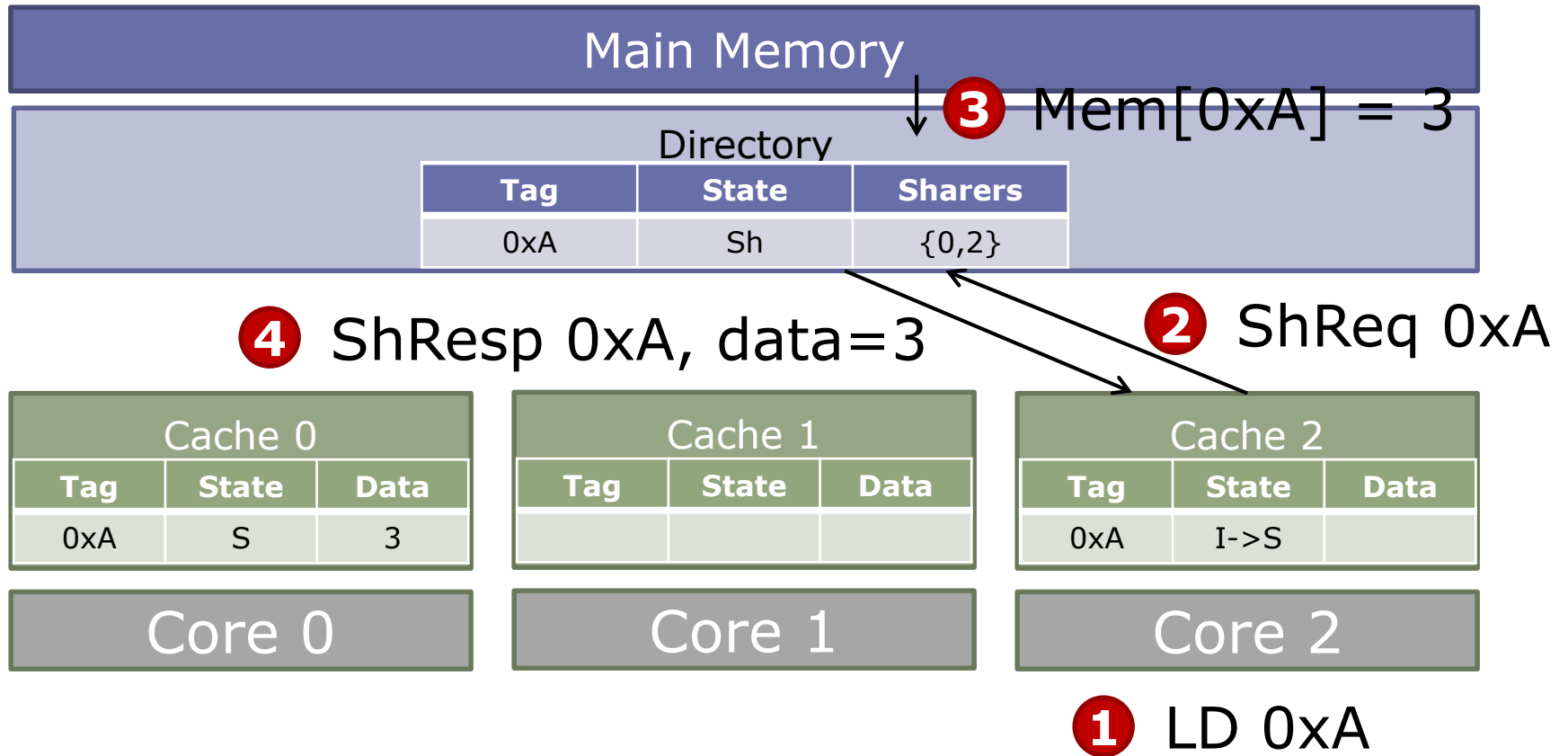

MSI Directory Protocol Example

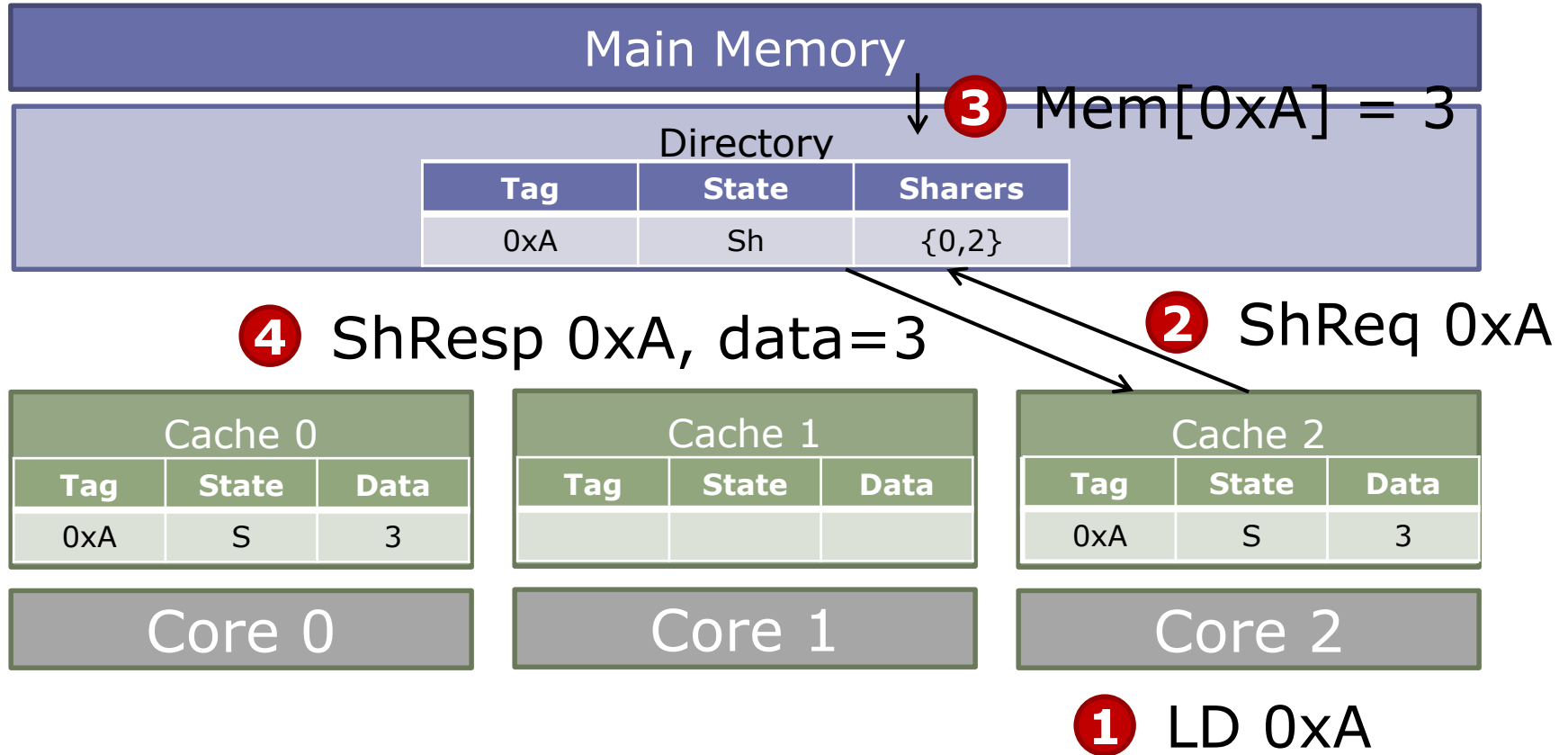

MSI Directory Protocol Example

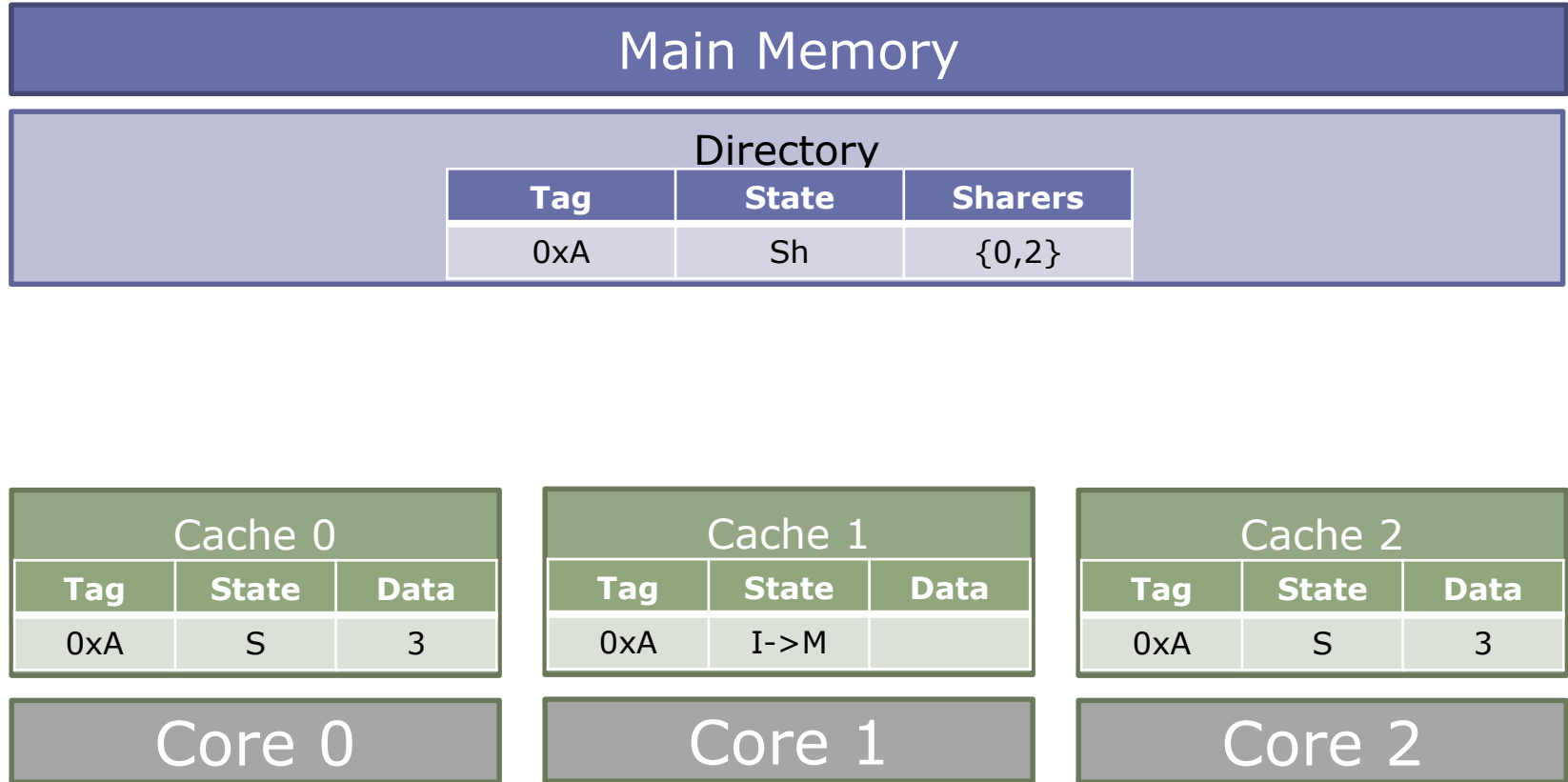

1 ST 0xA

MSI Directory Protocol Example

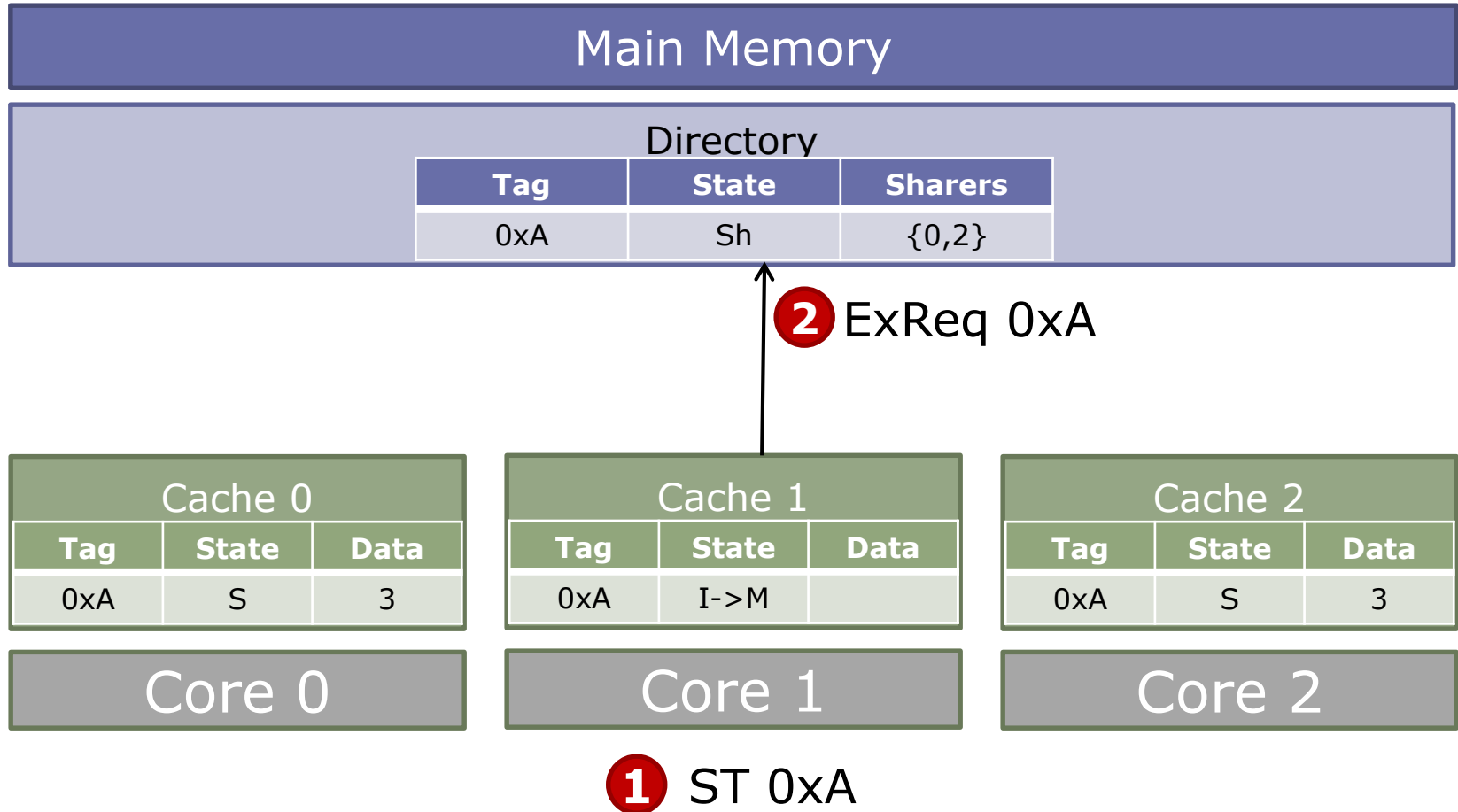

MSI Directory Protocol Example

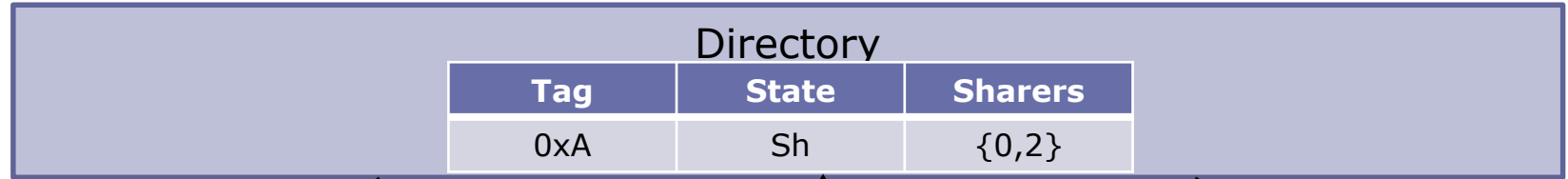

3 InvReq 0xA **2** ExReq 0xA **3** InvReq 0xA

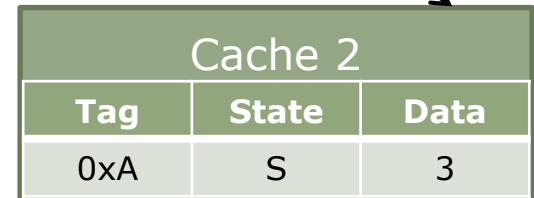
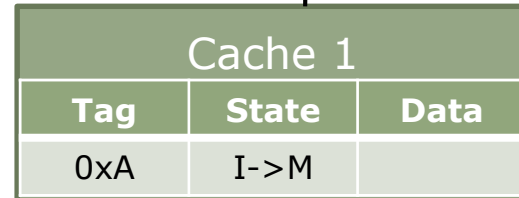
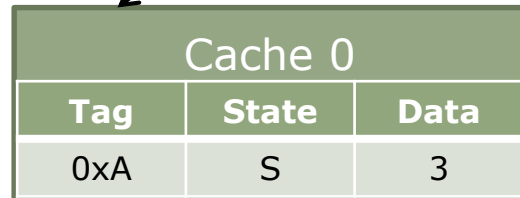

1 ST 0xA

MSI Directory Protocol Example

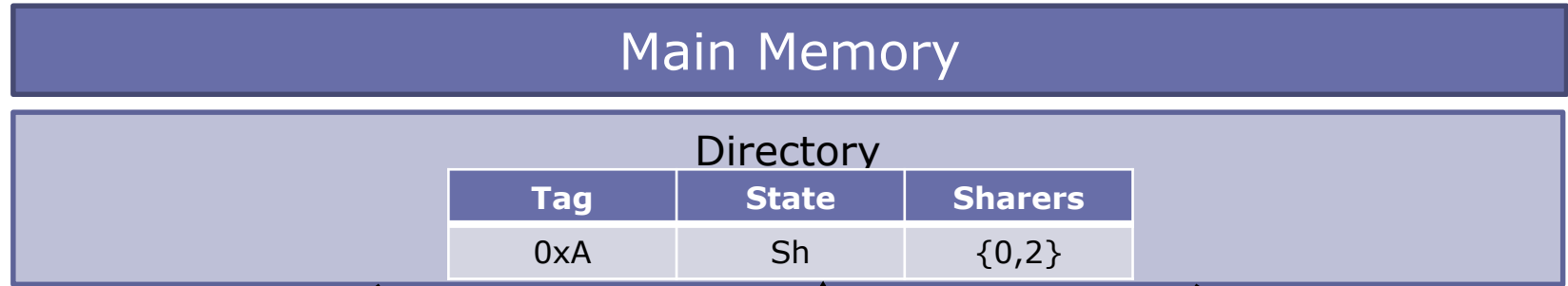

3 InvReq 0xA

2 ExReq 0xA

3 InvReq 0xA

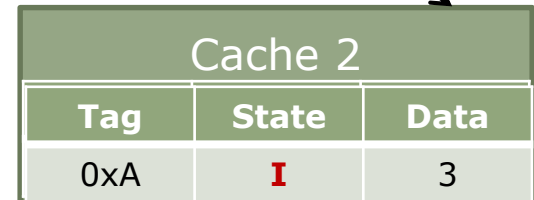
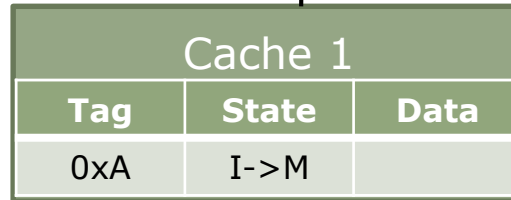
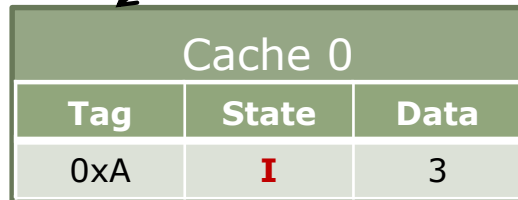

1 ST 0xA

MSI Directory Protocol Example

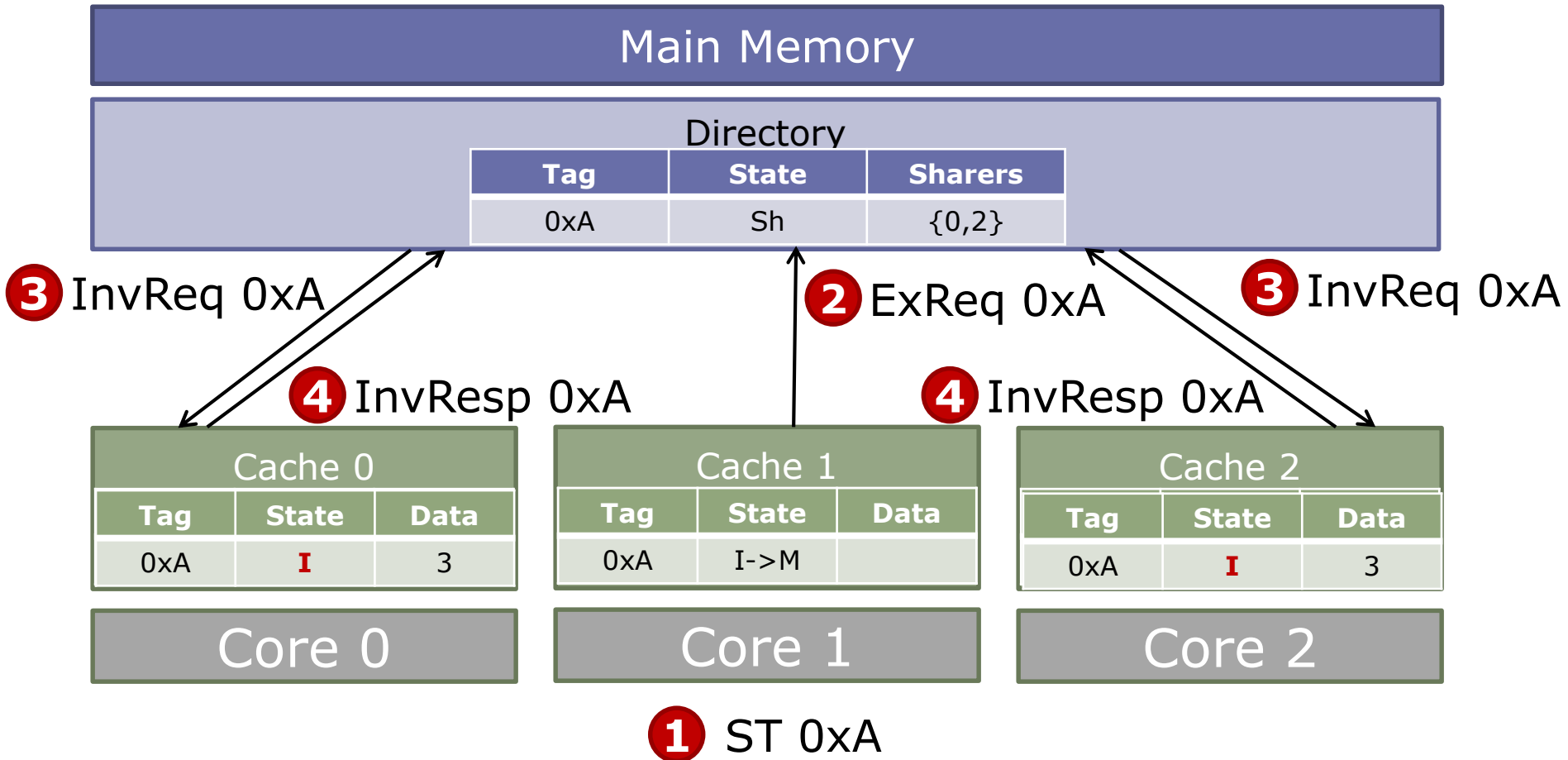

MSI Directory Protocol Example

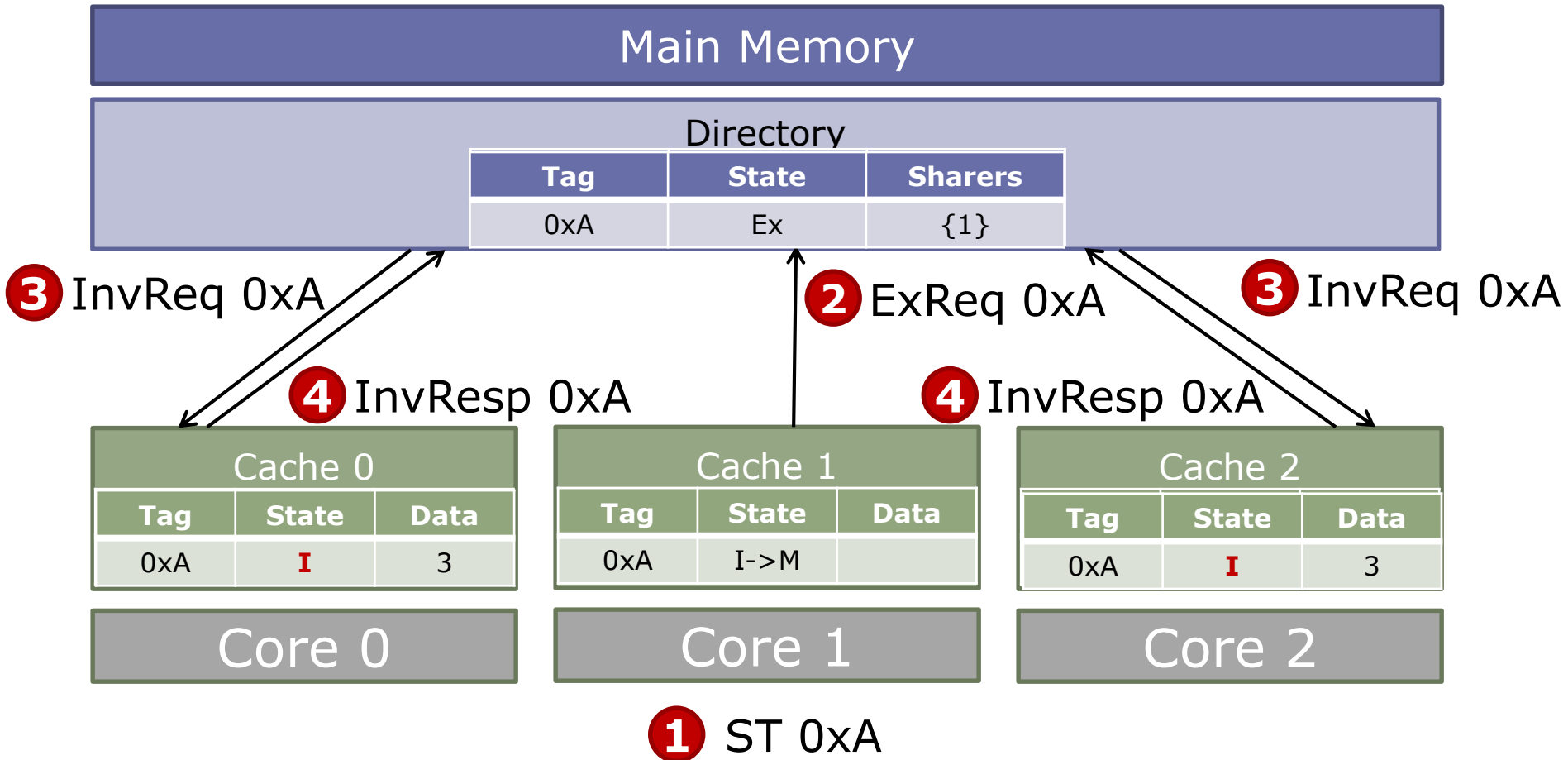

MSI Directory Protocol Example

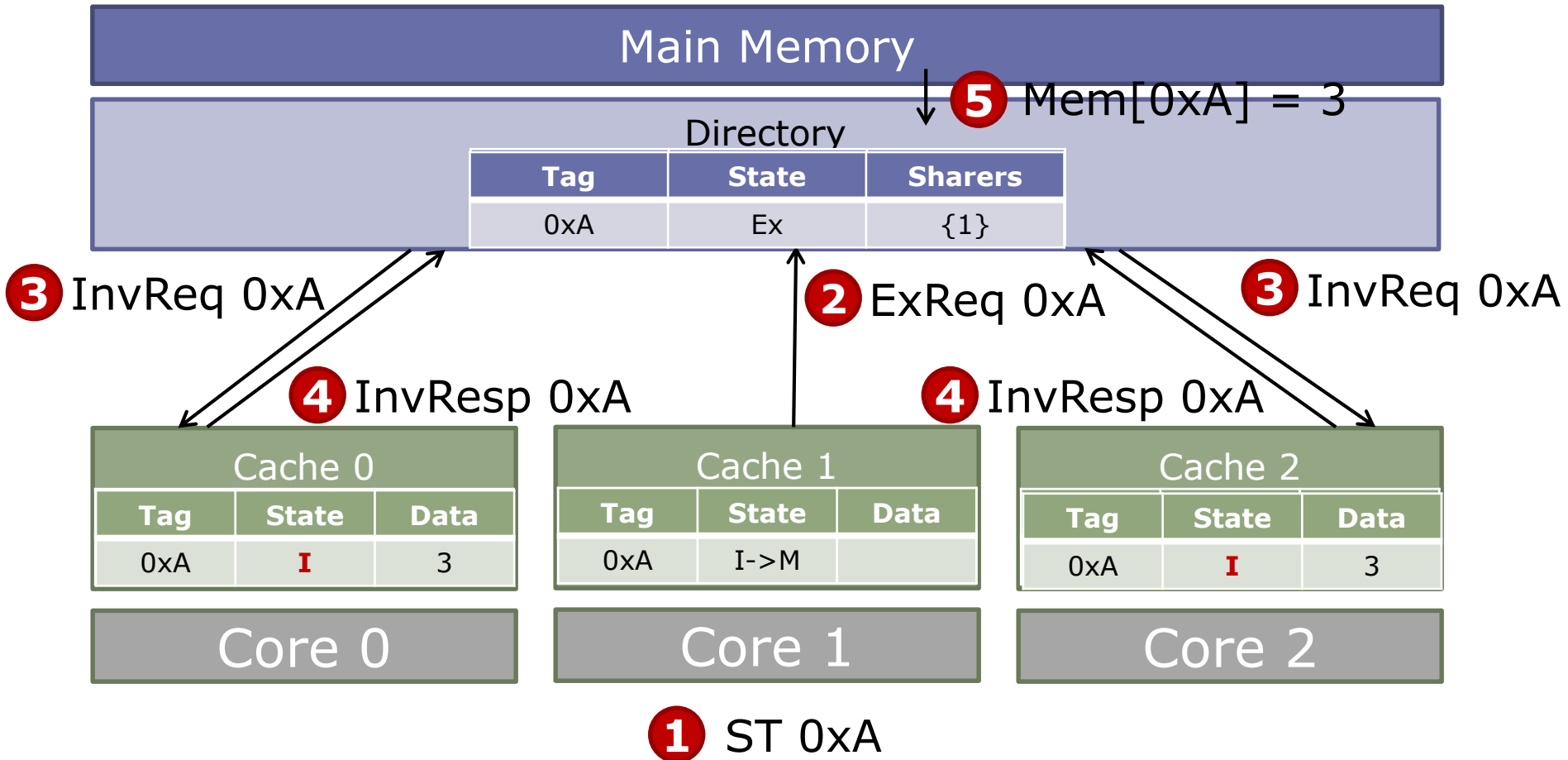

MSI Directory Protocol Example

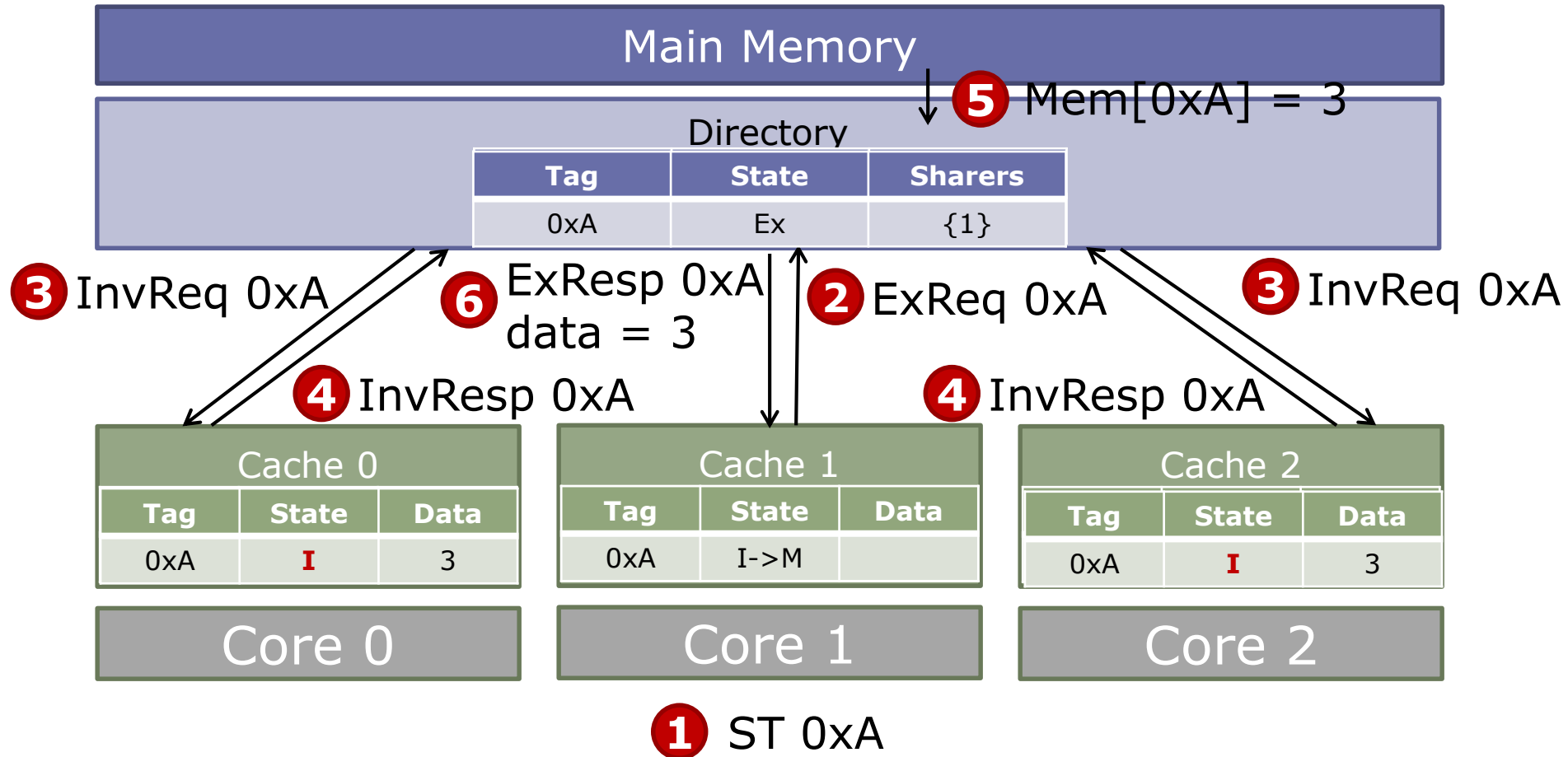

MSI Directory Protocol Example

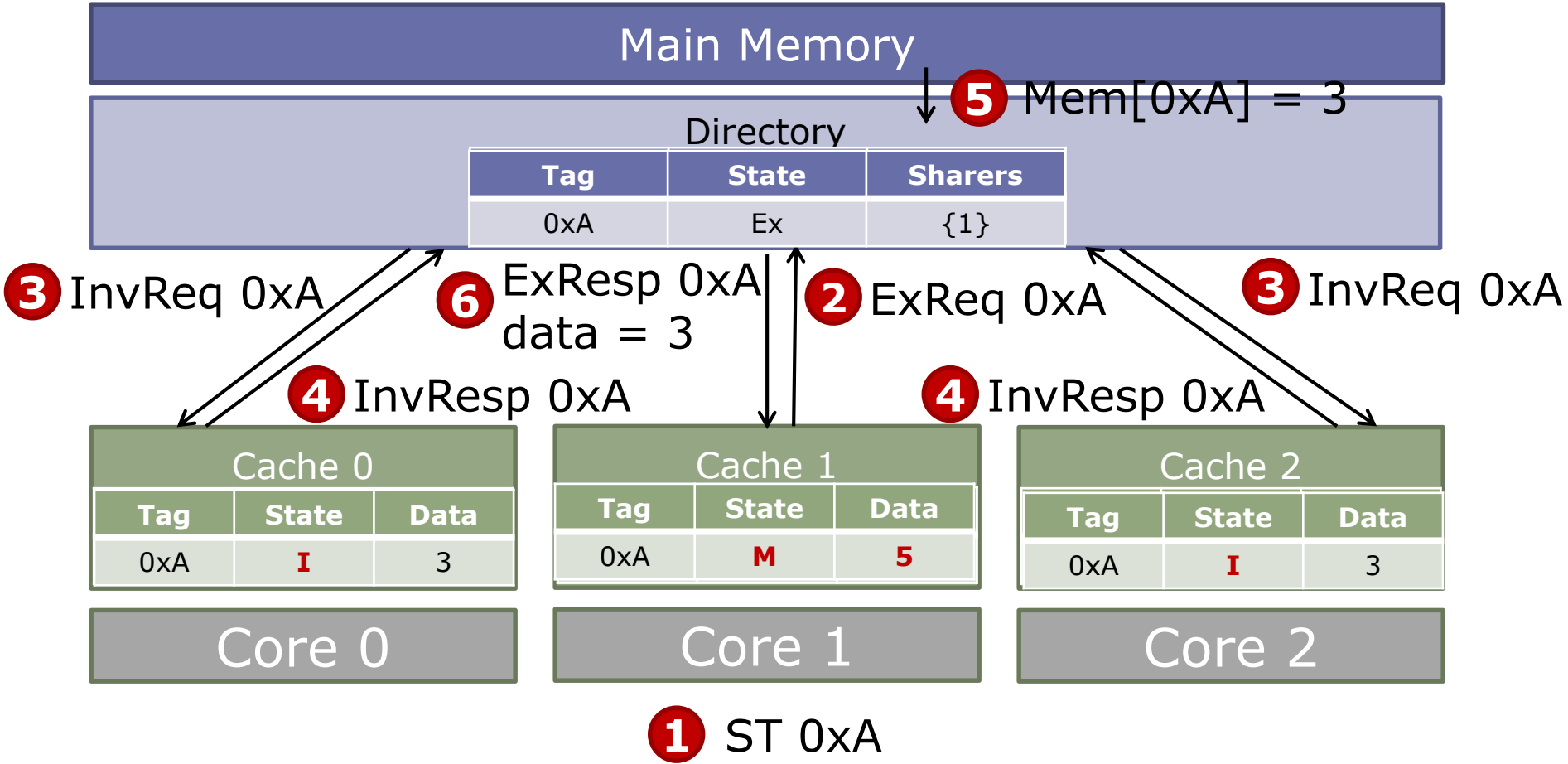

MSI Directory Protocol Example

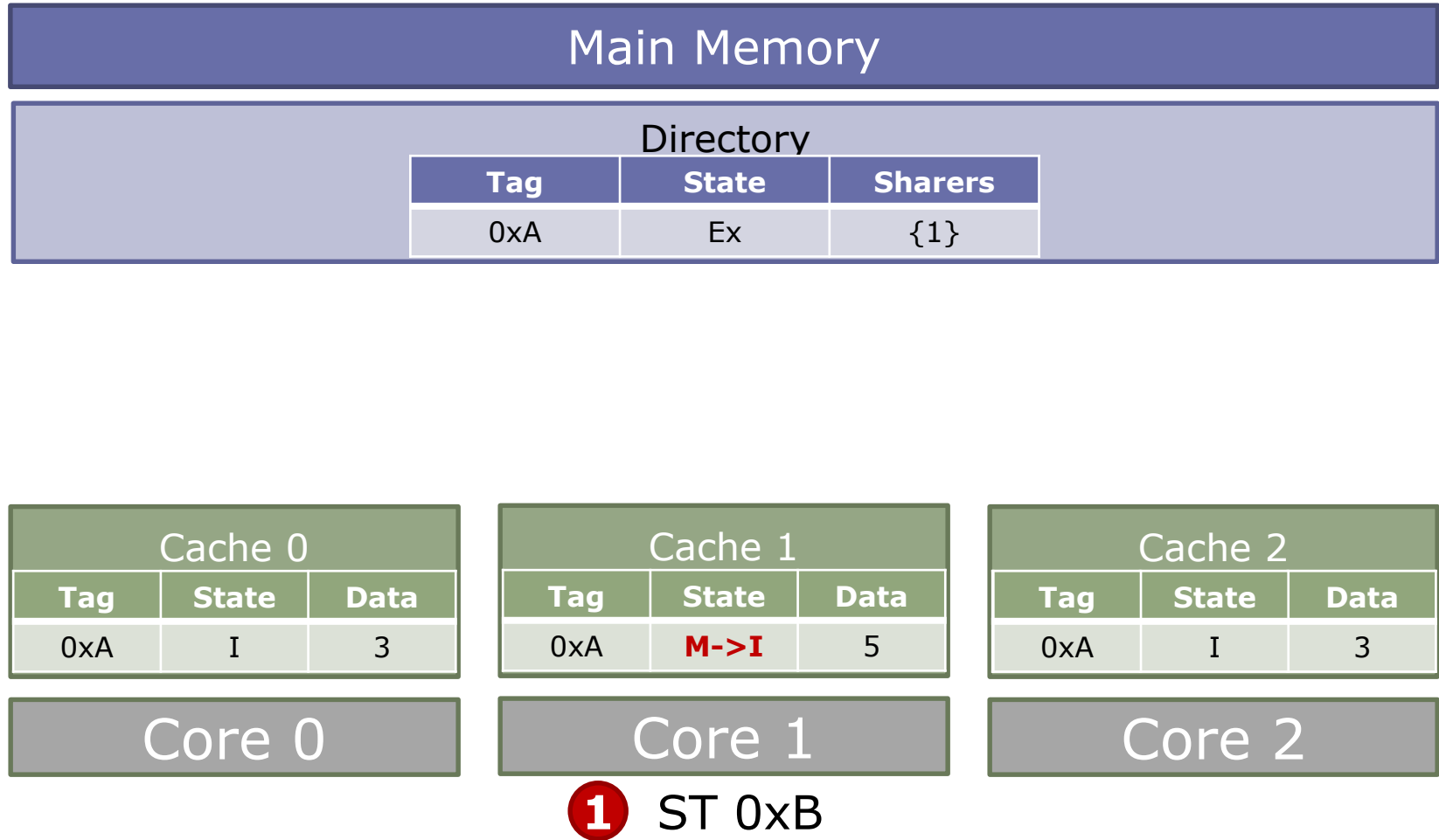

MSI Directory Protocol Example

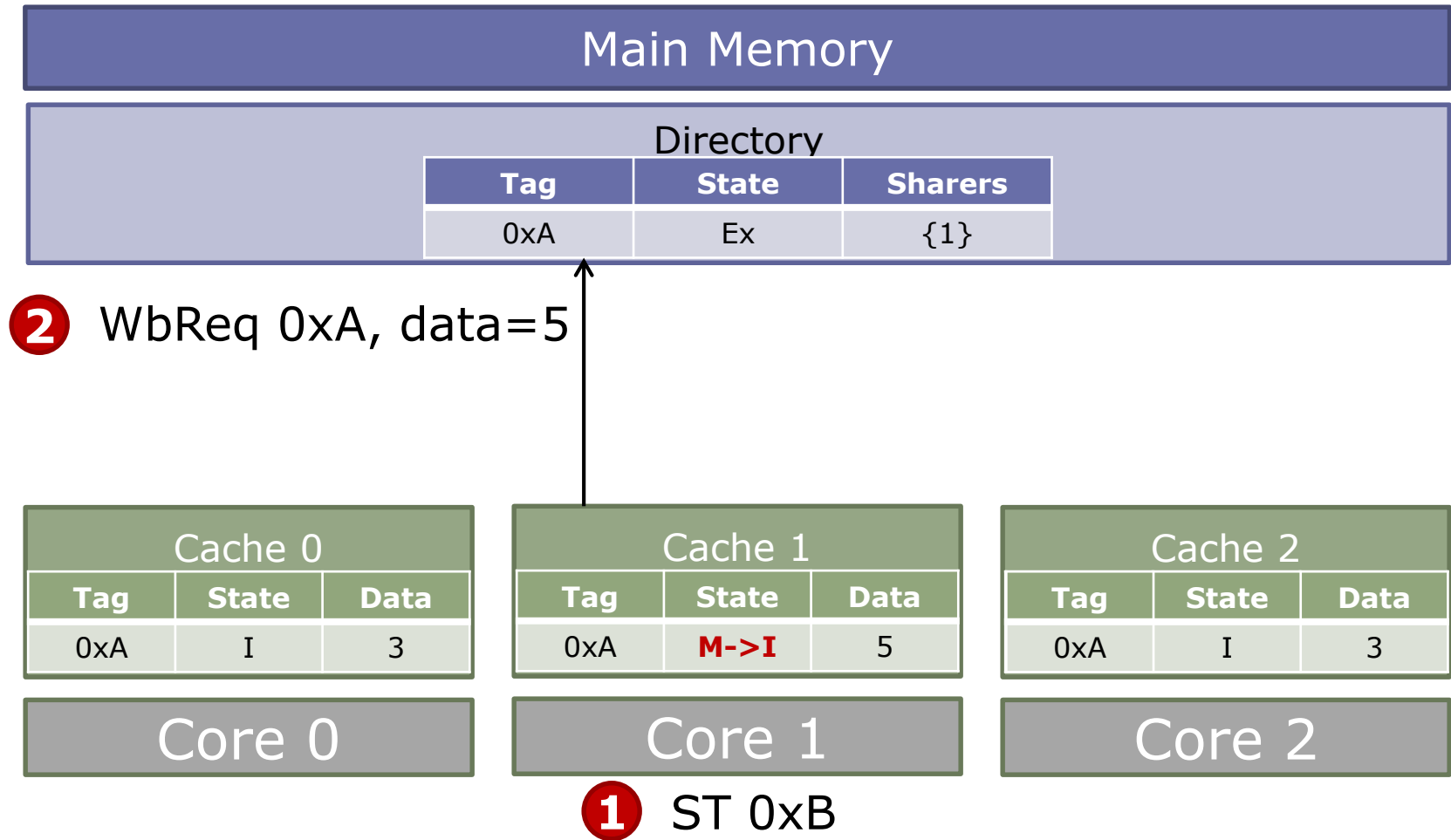

MSI Directory Protocol Example

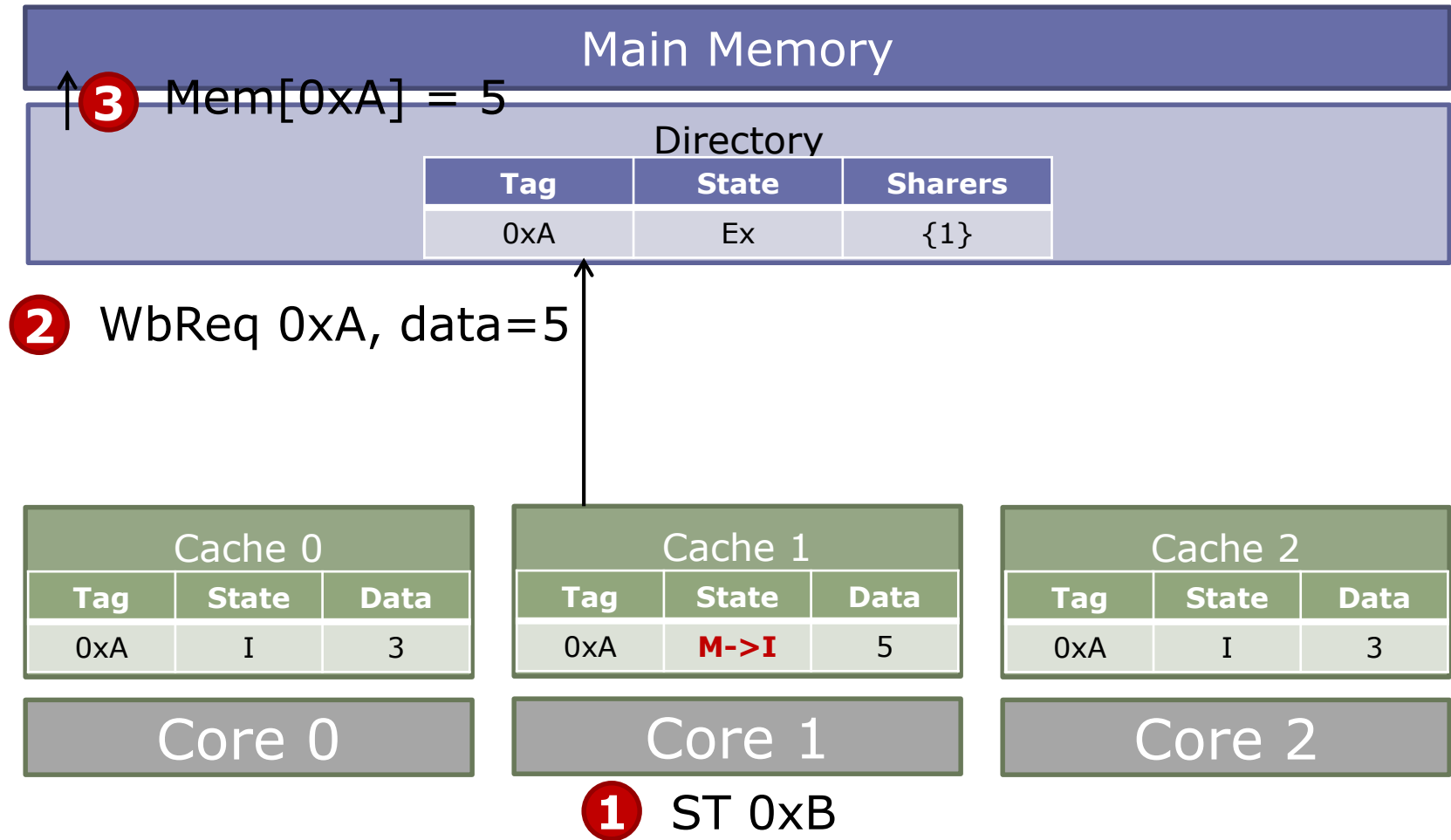

MSI Directory Protocol Example

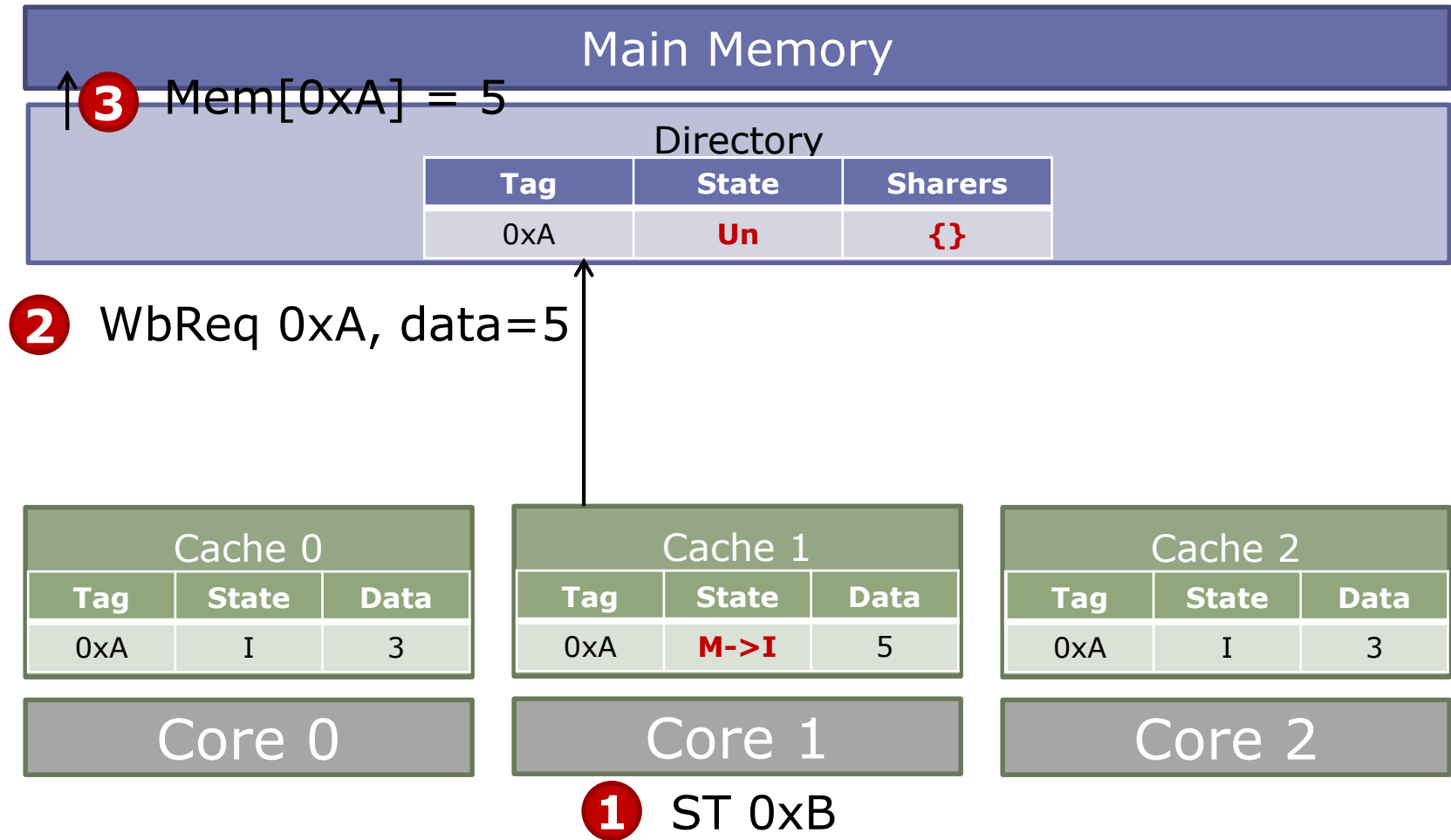

MSI Directory Protocol Example

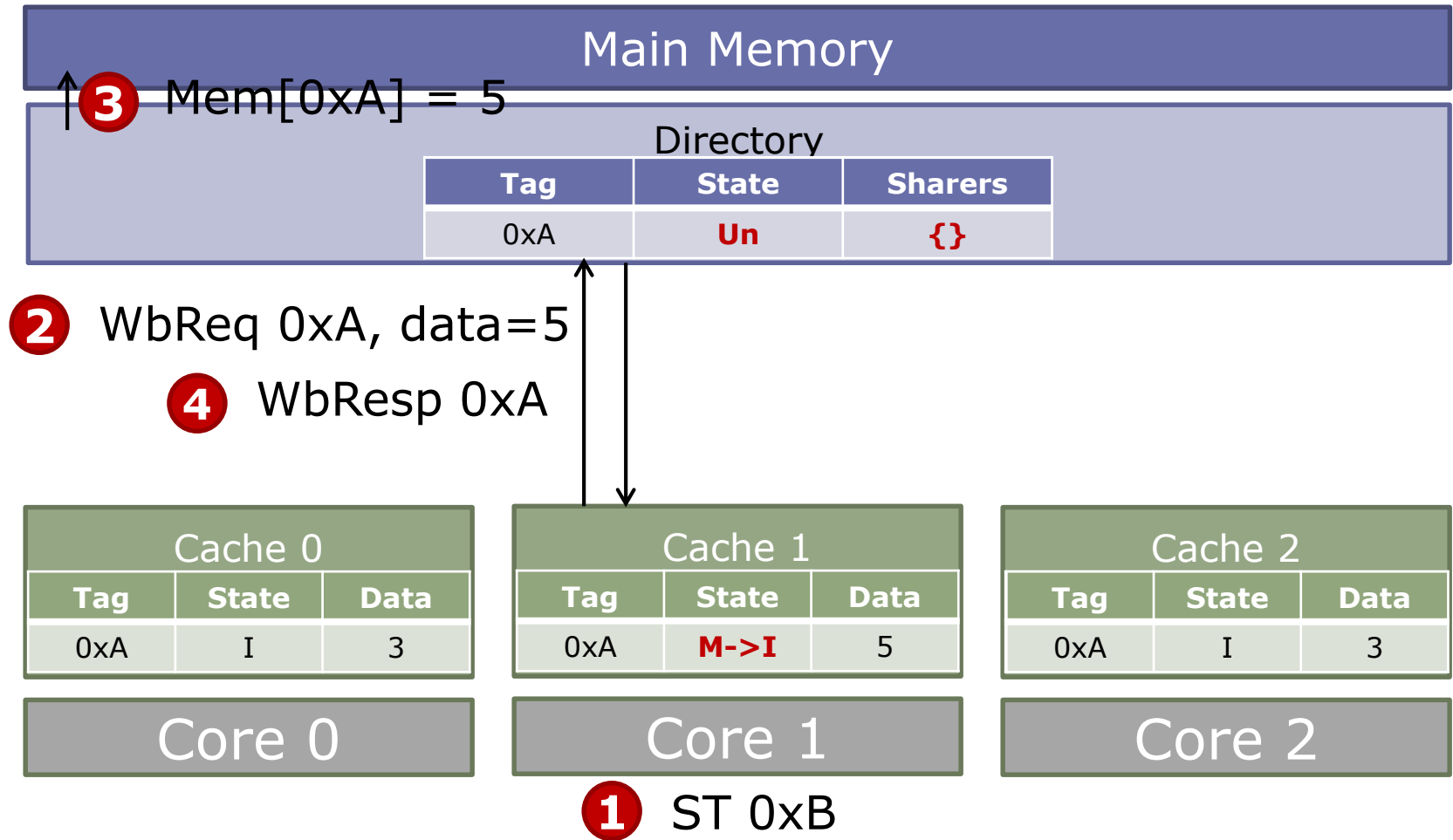

MSI Directory Protocol Example

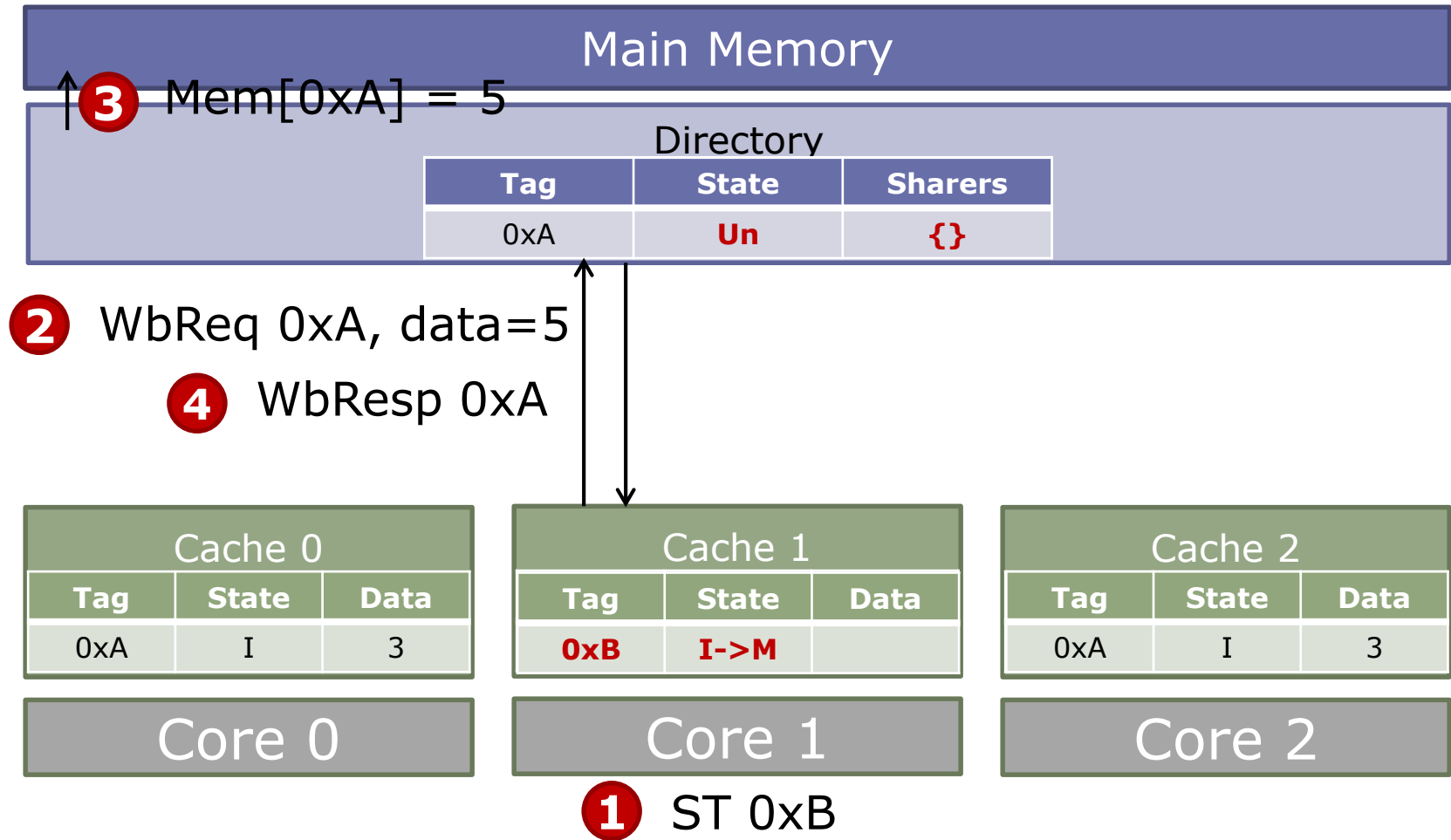

MSI Directory Protocol Example

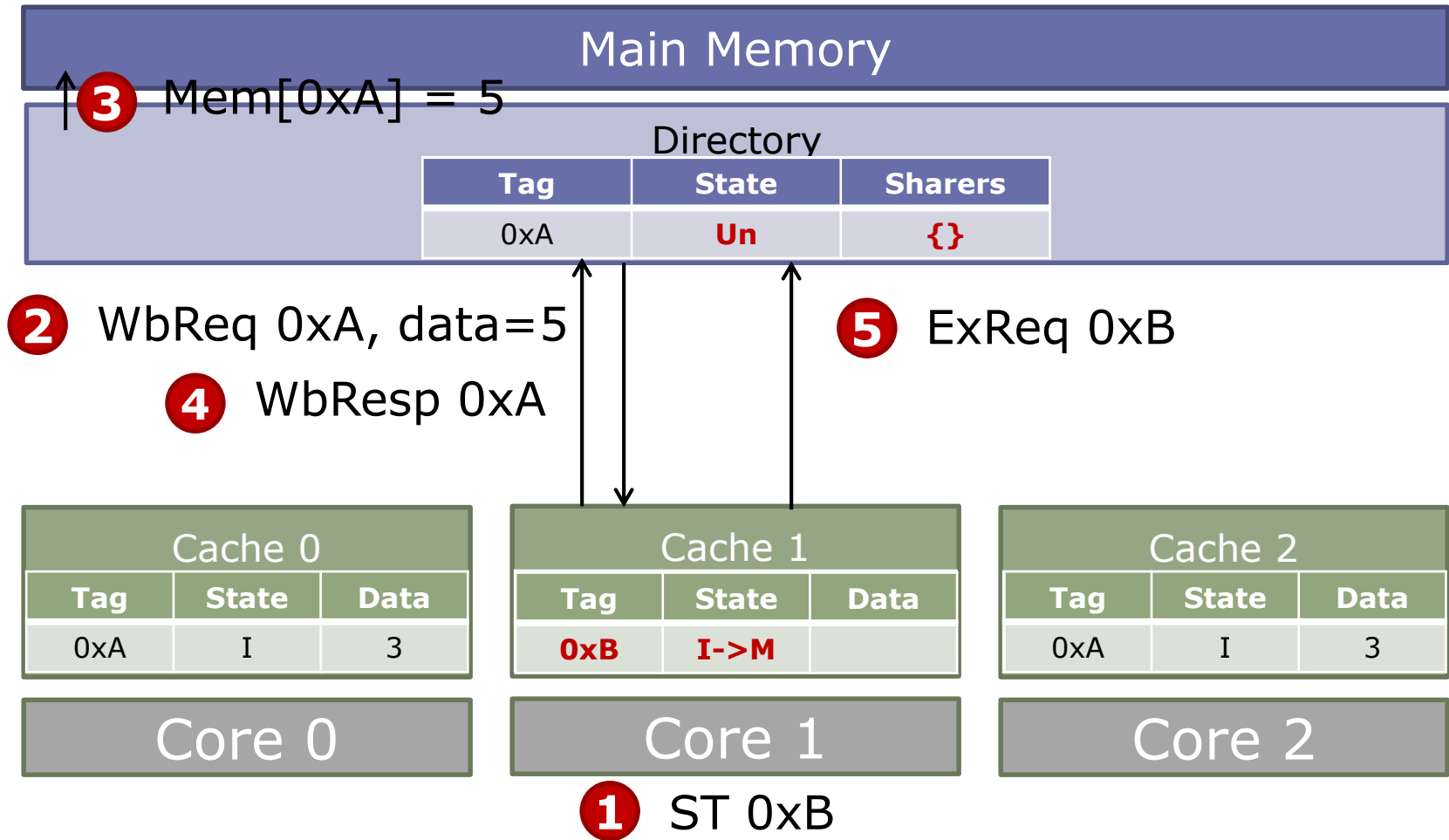

MSI Directory Protocol Example

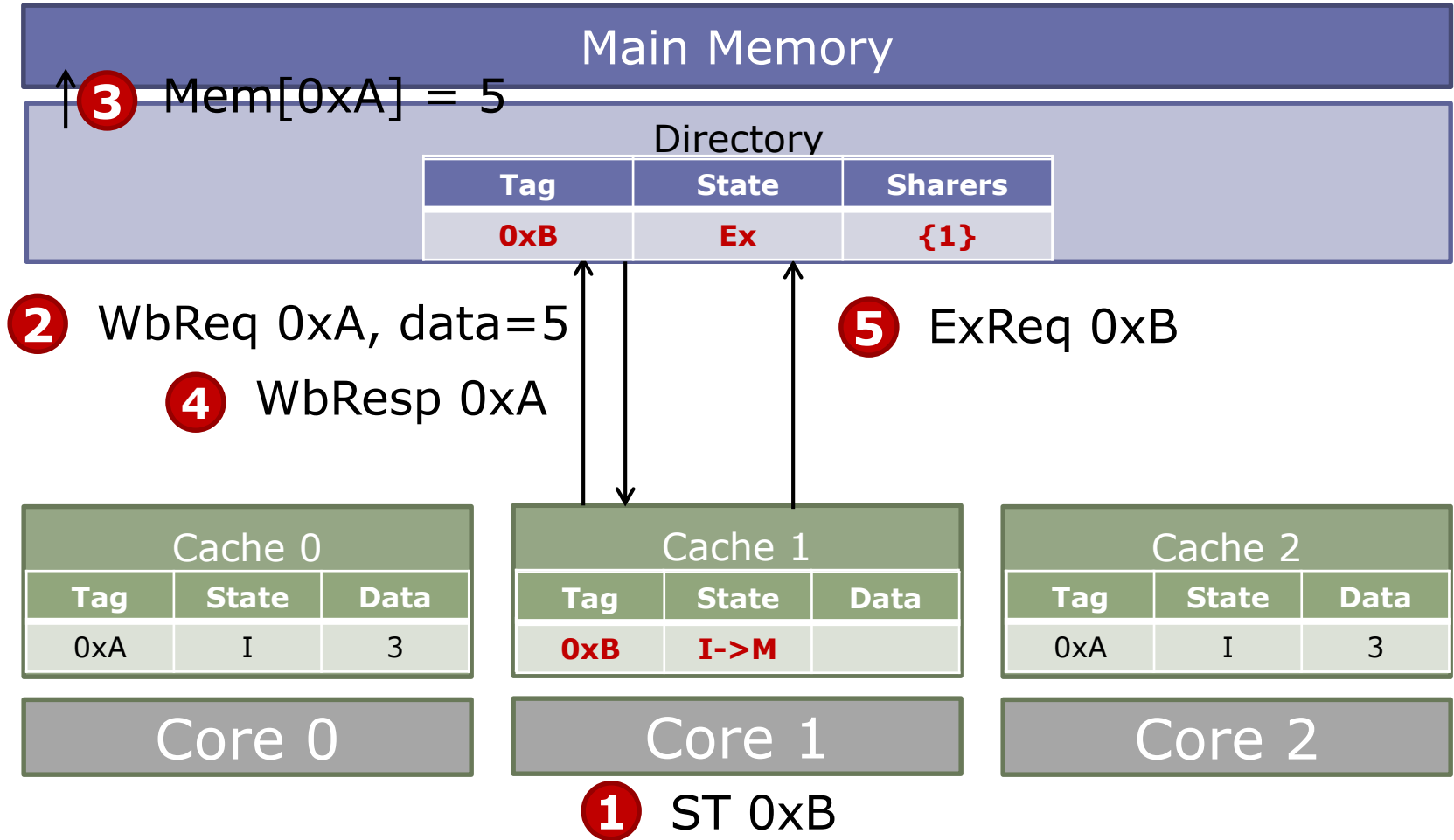

MSI Directory Protocol Example

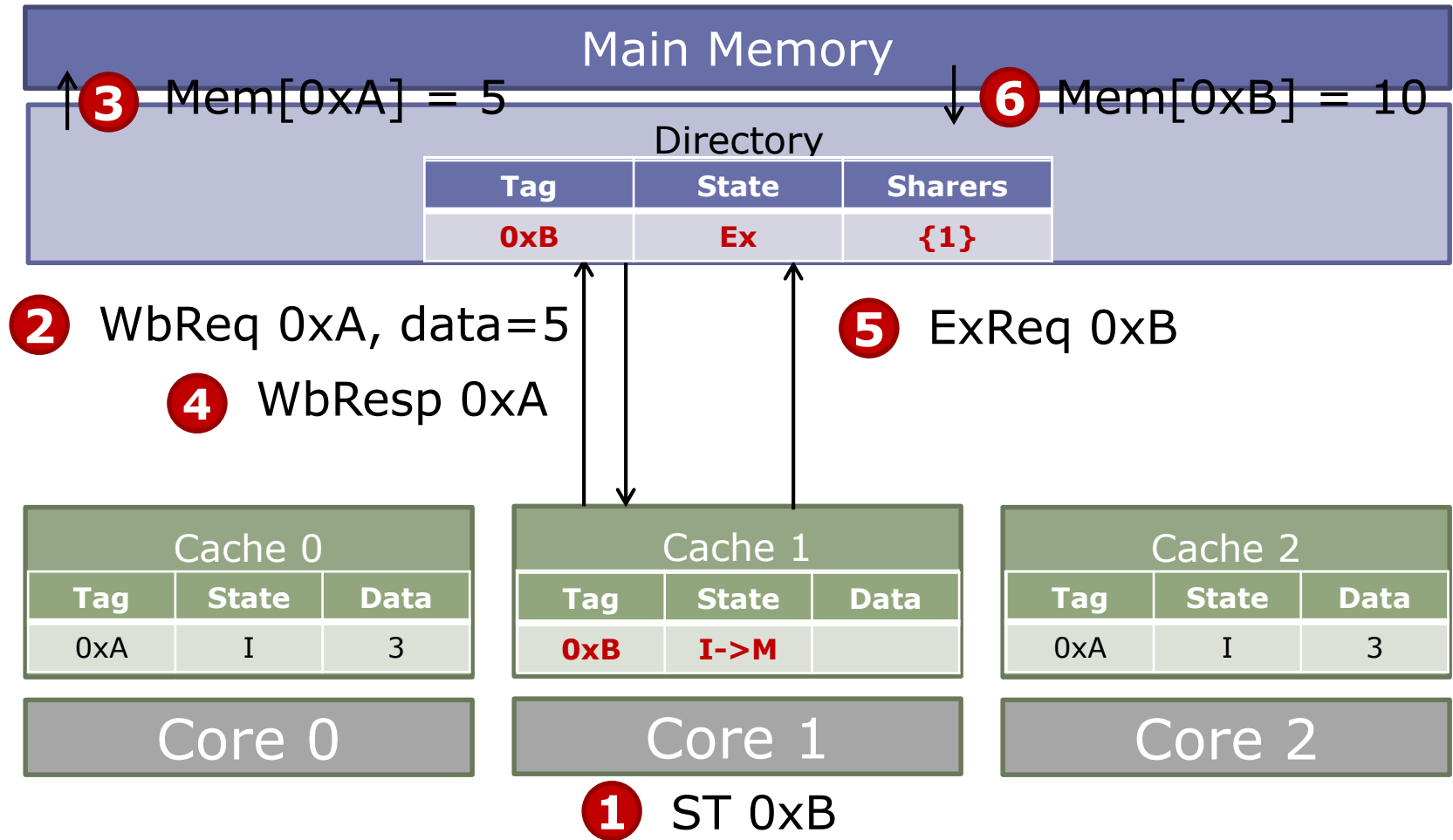

MSI Directory Protocol Example

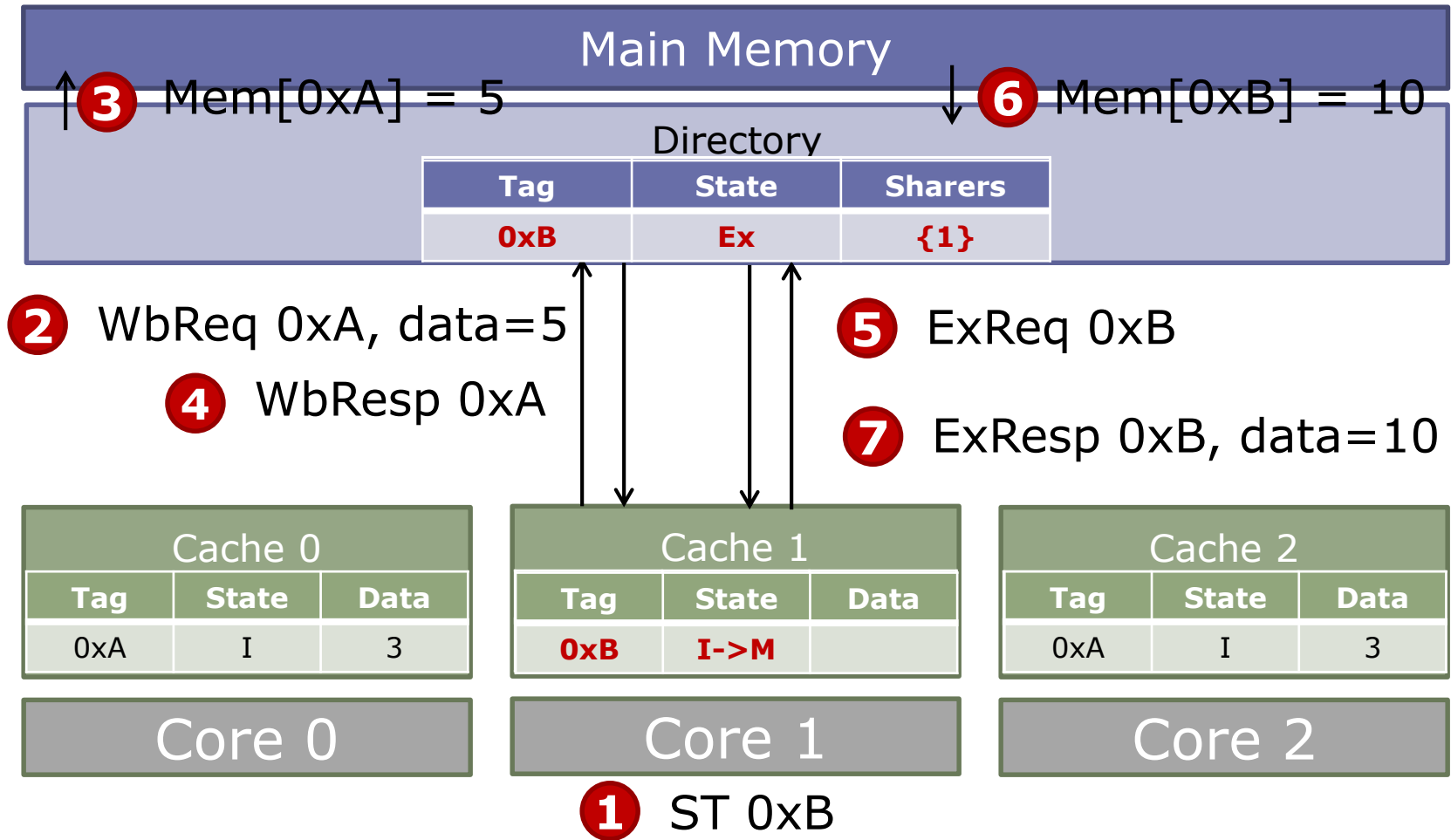

MSI Directory Protocol Example

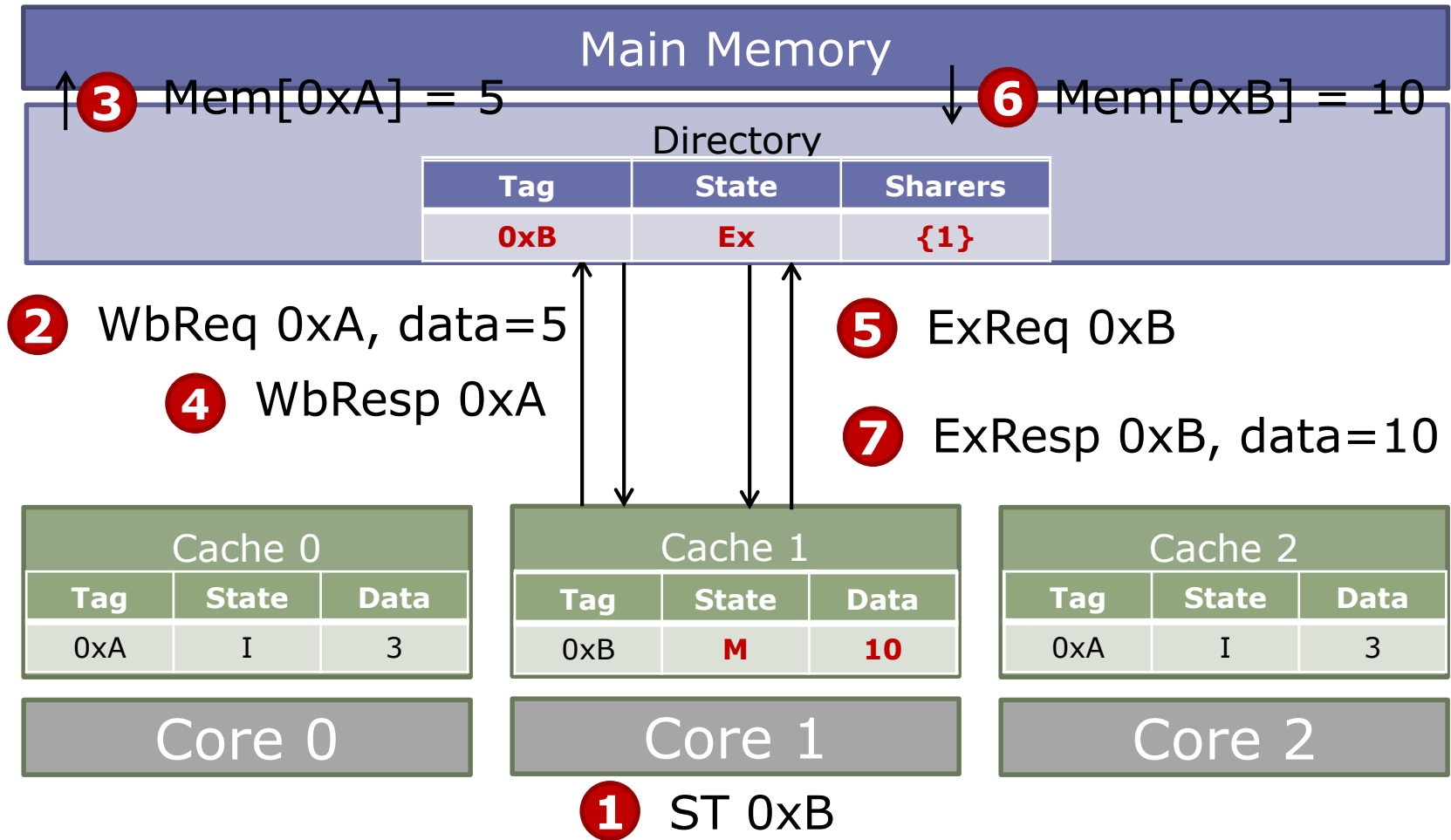

MSI Directory Protocol Example

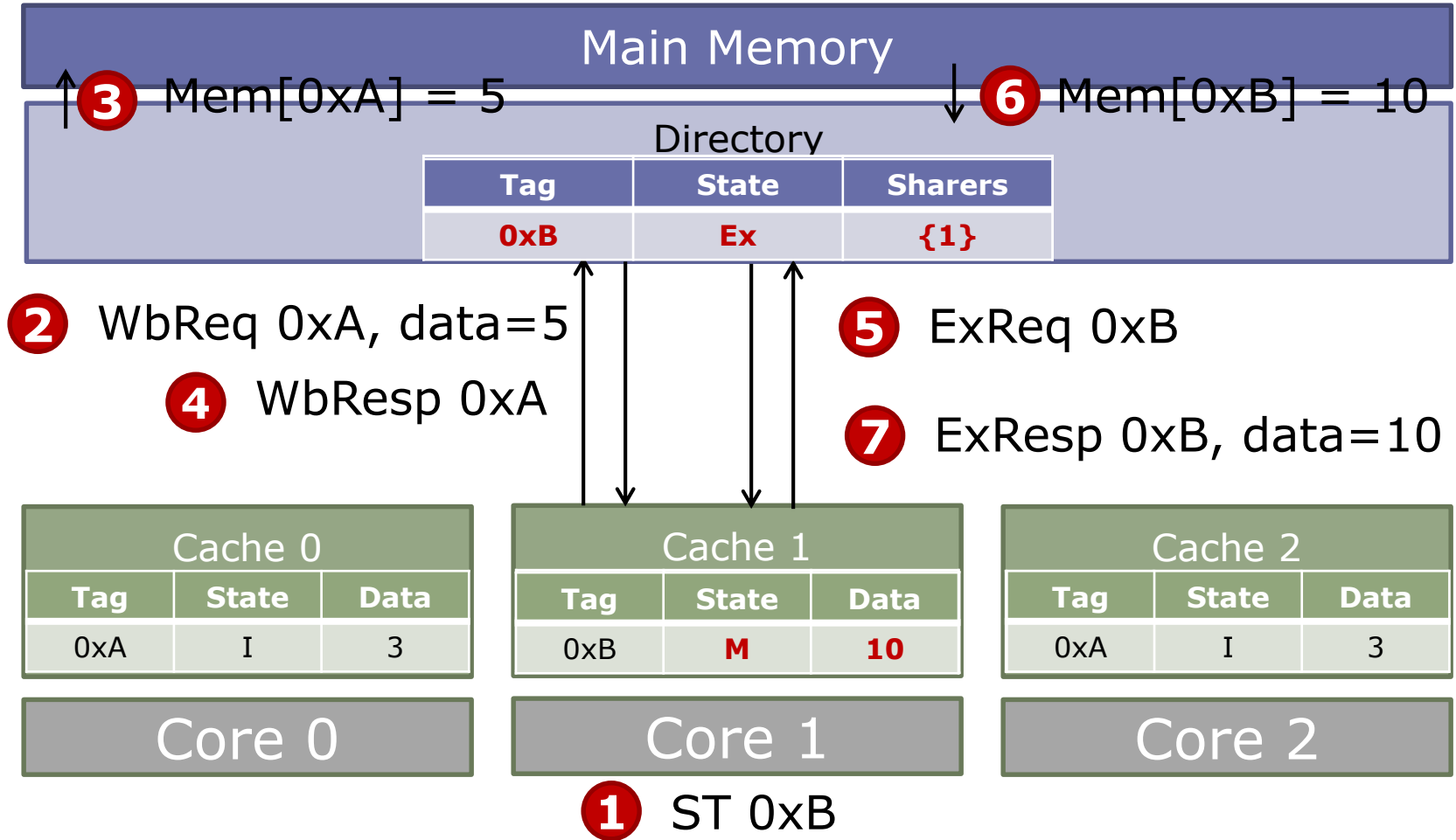

Why are 0xA's wb and 0xB's req serialized?

MSI Directory Protocol Example

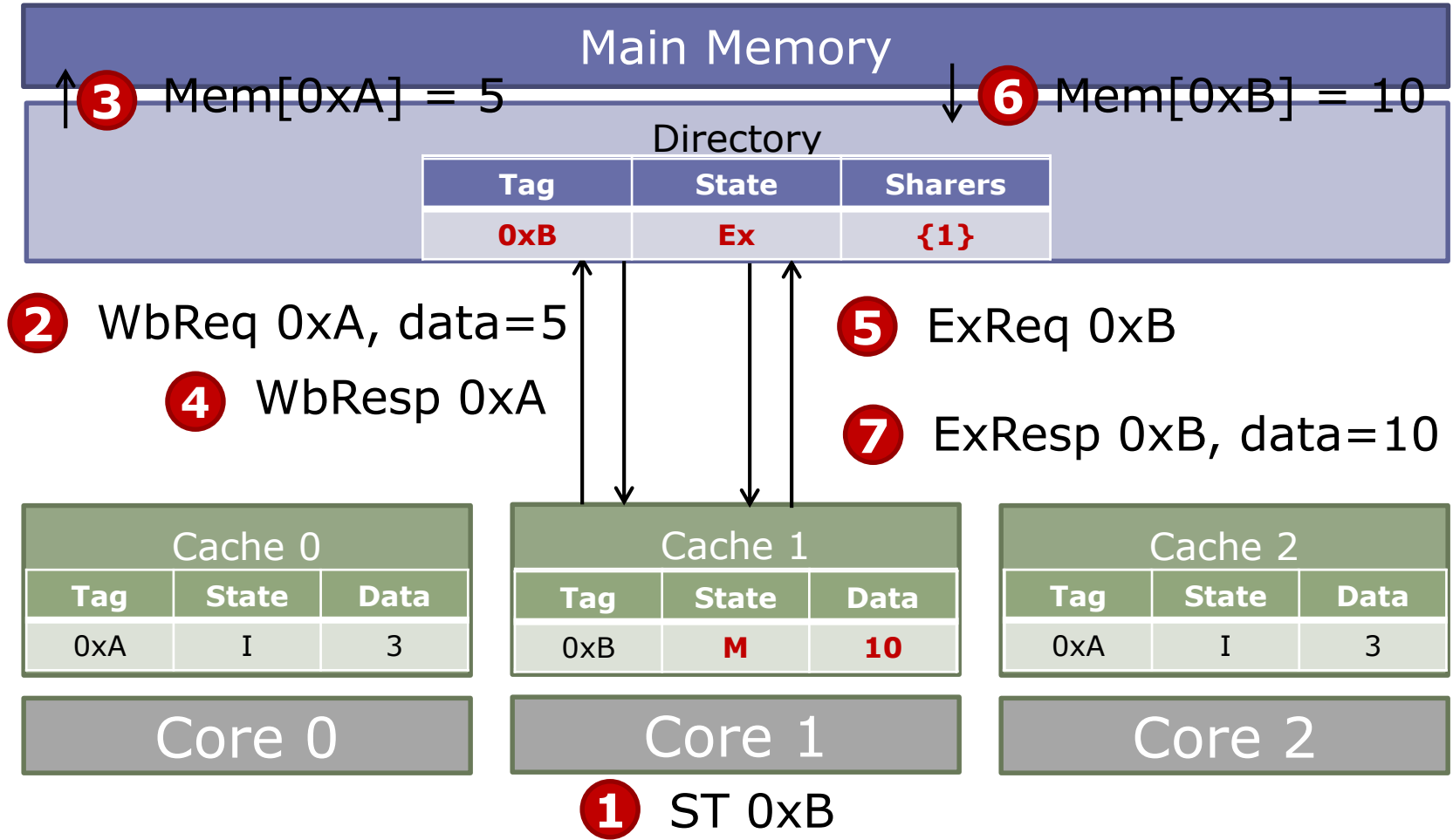

Why are 0xA's wb and 0xB's req serialized?

Structural dependence

MSI Directory Protocol Example

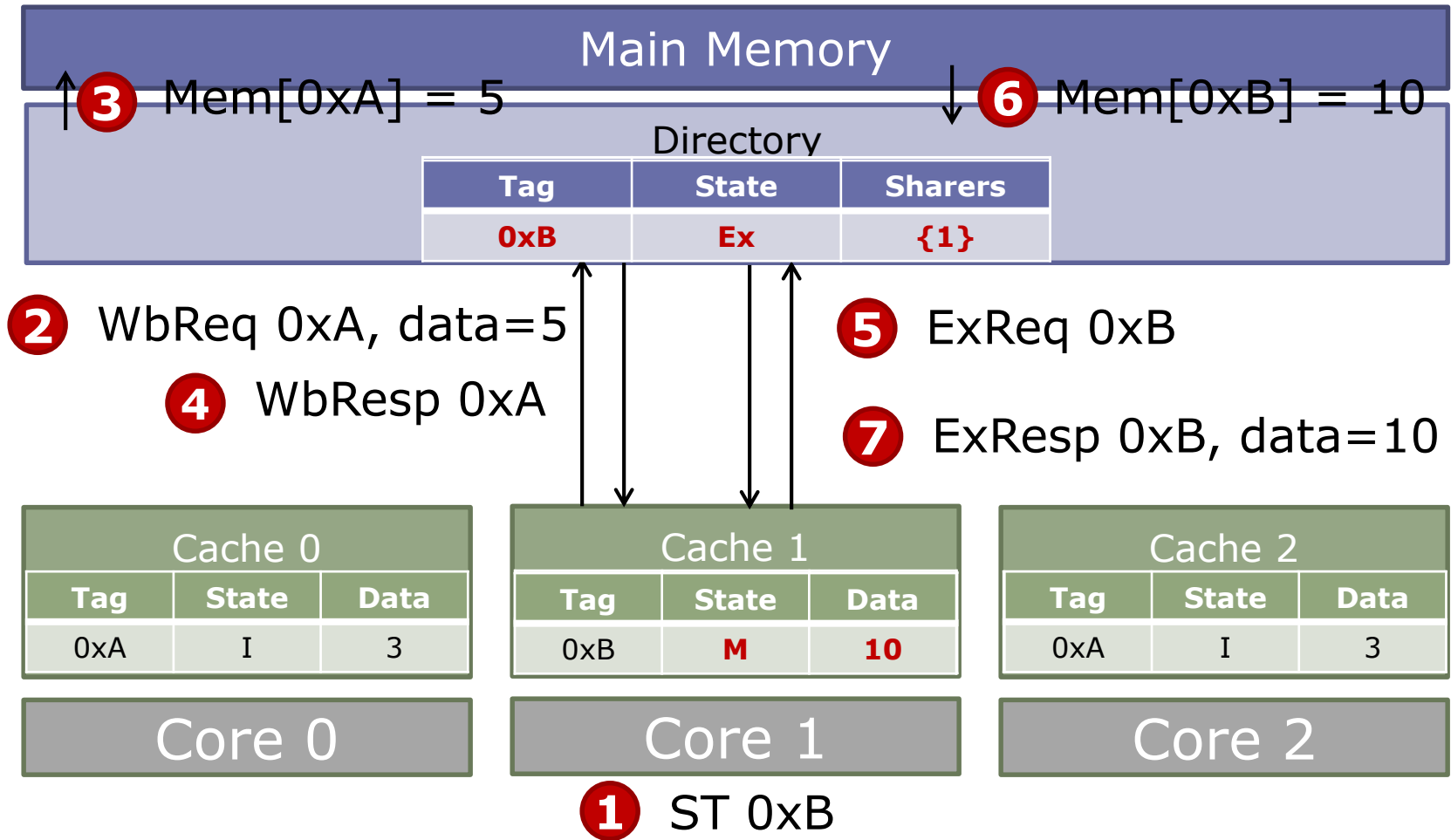

Why are 0xA's wb and 0xB's req serialized?
Possible solutions?

Structural dependence

MSI Directory Protocol Example

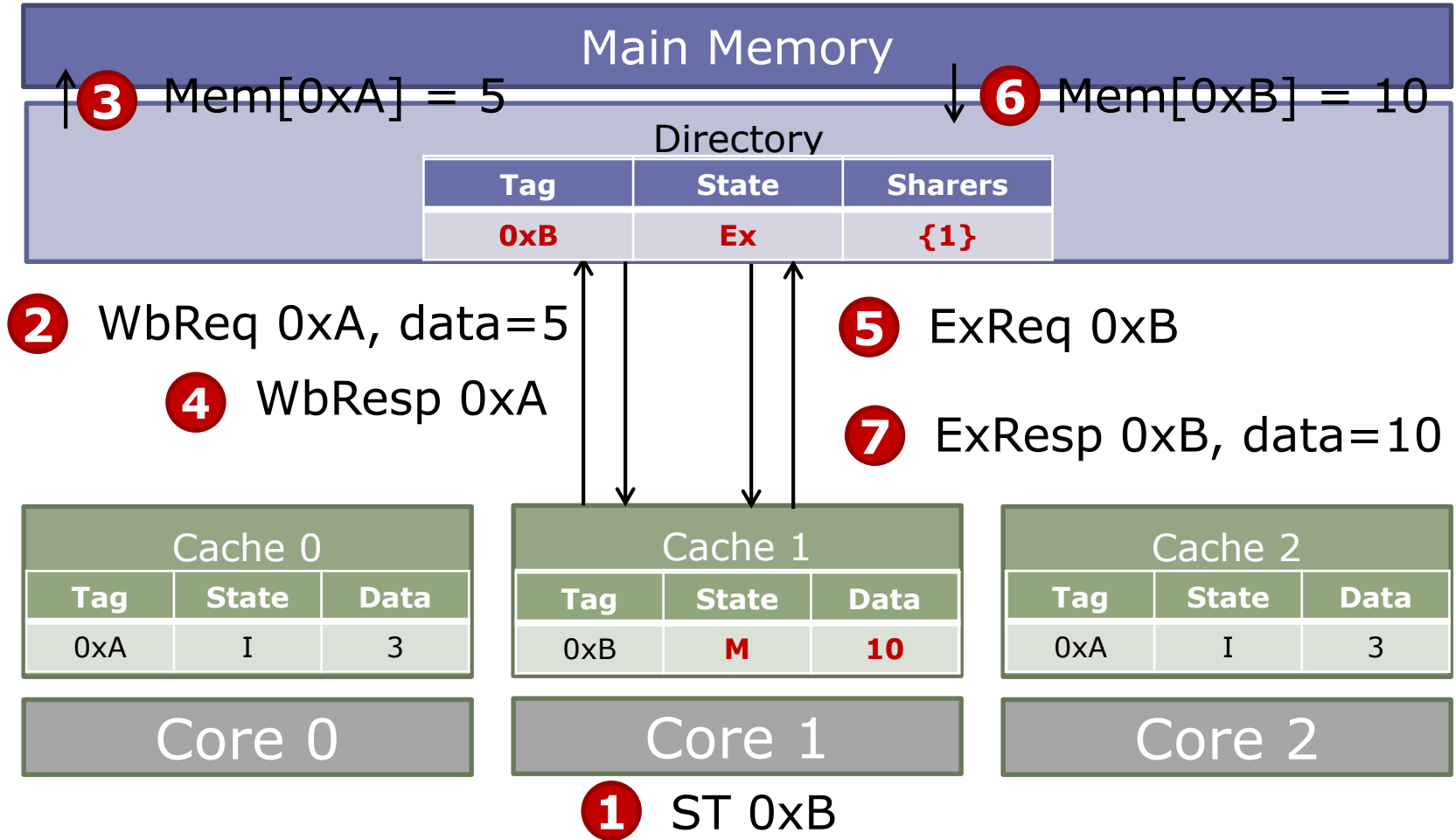

Why are 0xA's wb and 0xB's req serialized? **Structural dependence**

Possible solutions? **Buffer outside of cache to hold write data**

Miss Status Holding Register

MSHR – Holds load misses and writes outside of cache

MSHR entry



- On eviction/writeback
 - No free MSHR entry: stall
 - Allocate new MSHR entry
 - When channel available send WBReq and data
 - Deallocate entry on WBResp

Miss Status Holding Register

MSHR – Holds load misses and writes outside of cache

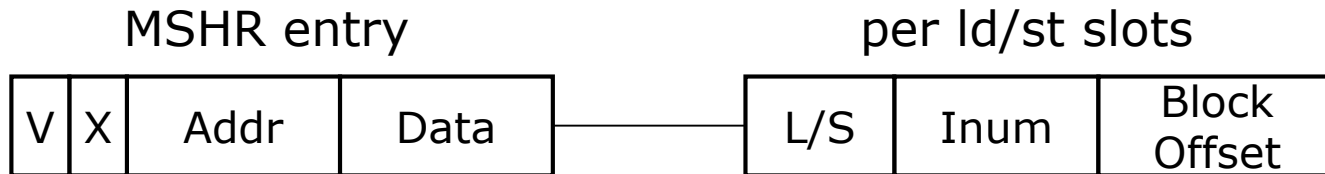

- On cache load miss
 - No free MSHR entry: stall
 - Allocate new MSHR entry
 - Send ShReq (or ExReq)
 - On *Resp forward data to CPU and cache
 - Deallocate MSHR

Miss Status Holding Register

MSHR – Holds load misses and writes outside of cache

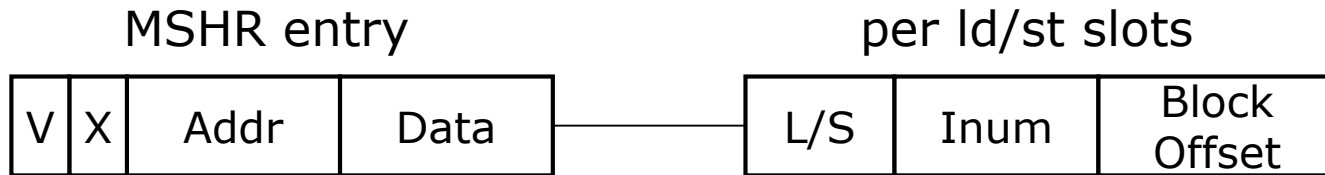

Miss Status Holding Register

MSHR – Holds load misses and writes outside of cache

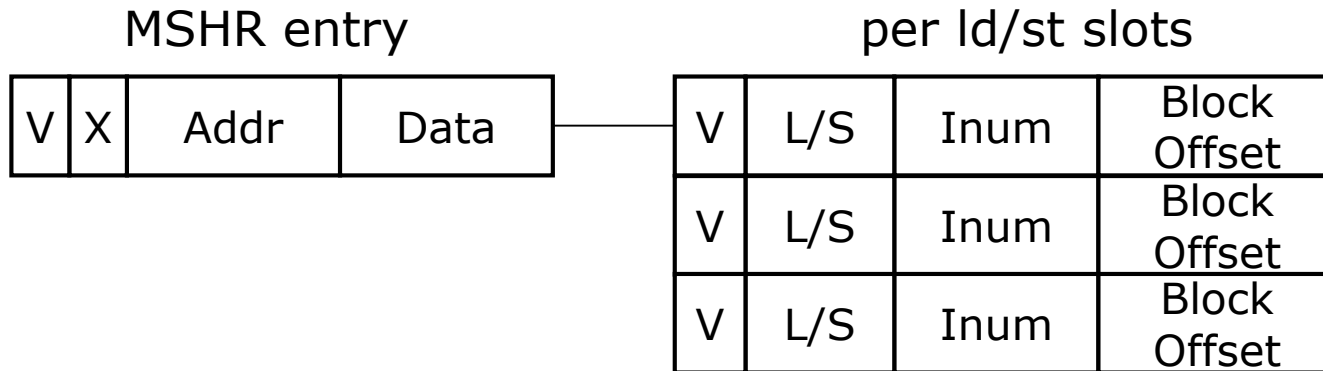

Per Id/st slots allow servicing multiple requests with one entry

Miss Status Holding Register

MSHR – Holds load misses and writes outside of cache

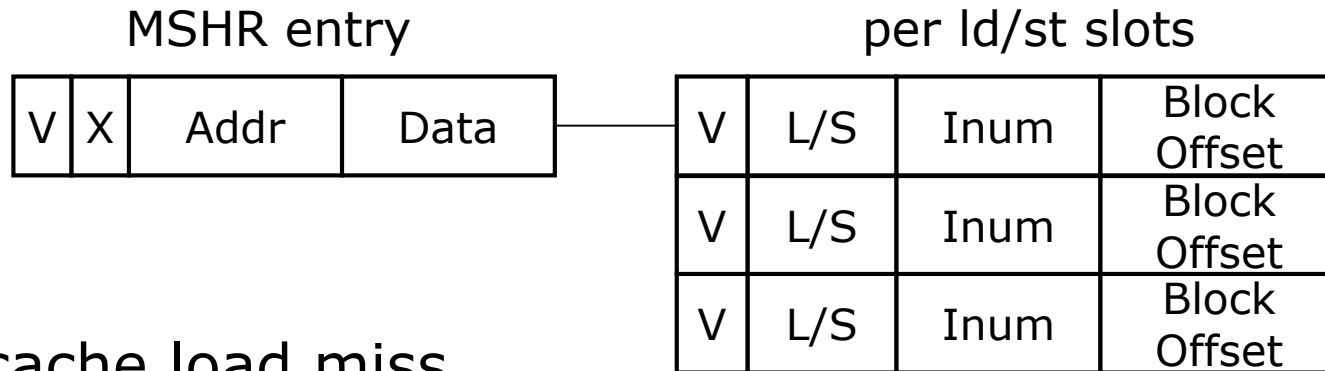

- On cache load miss
 - Look for matching address in MSHRs
 - If not found
 - If no free MSHR entry: stall
 - Allocate new MSHR entry and fill in
 - If found, just fill in per Id/st slot
 - Send ShReq (or ExReq)
 - On *Resp forward data to CPU and cache
 - Deallocate MSHR

Per Id/st slots allow servicing multiple requests with one entry

Directory Organization

- Requirement: Directory needs to keep track of all the cores that are sharing a cache block
- Challenge: For each block, the space needed to hold the list of sharers grows with number of possible sharers...

Flat, Memory-based Directories

- Dedicate a few bits of main memory to store the state and sharers of every line
- Encode sharers using a bit-vector

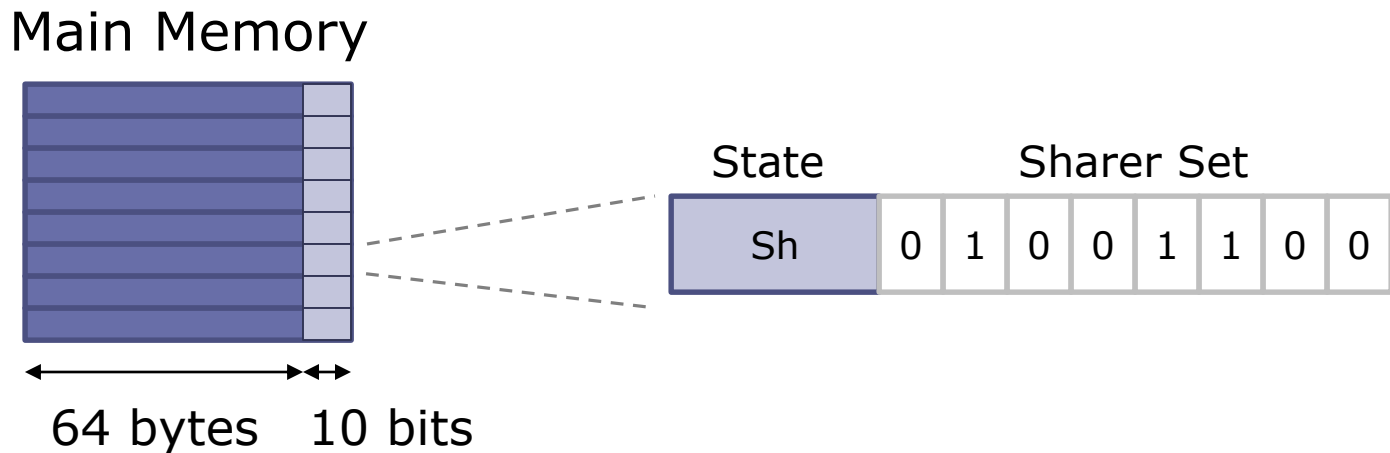

Flat, Memory-based Directories

- Dedicate a few bits of main memory to store the state and sharers of every line
- Encode sharers using a bit-vector

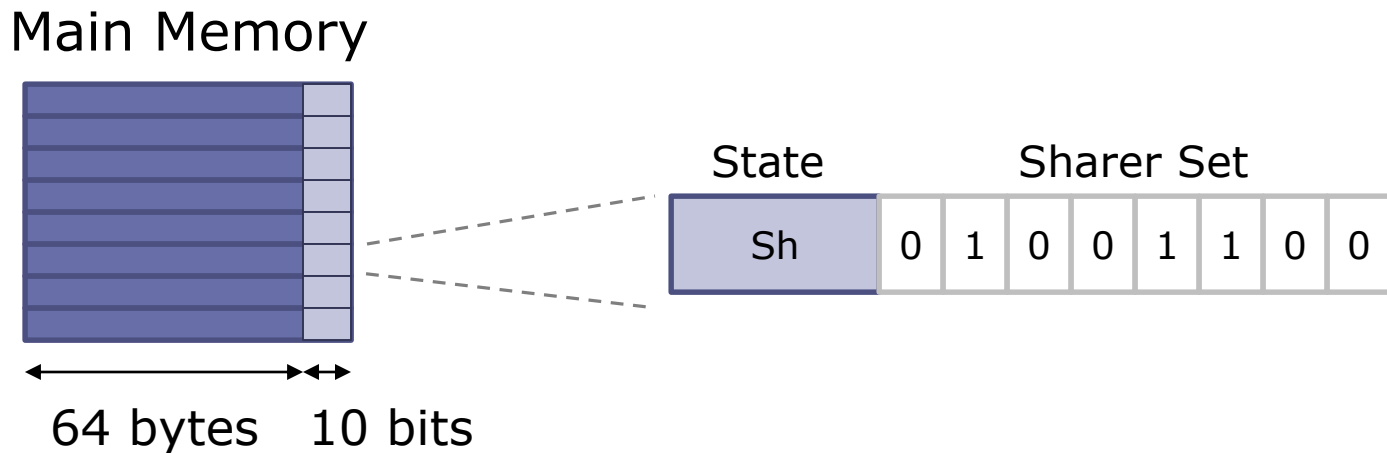

✓ Simple

✗ Slow

✗ Very inefficient with many processors ($\sim P$ bits/line)

Sparse Full-Map Directories

- Not every line in the system needs to be tracked – only those in private caches!
- Idea: Organize directory as a cache

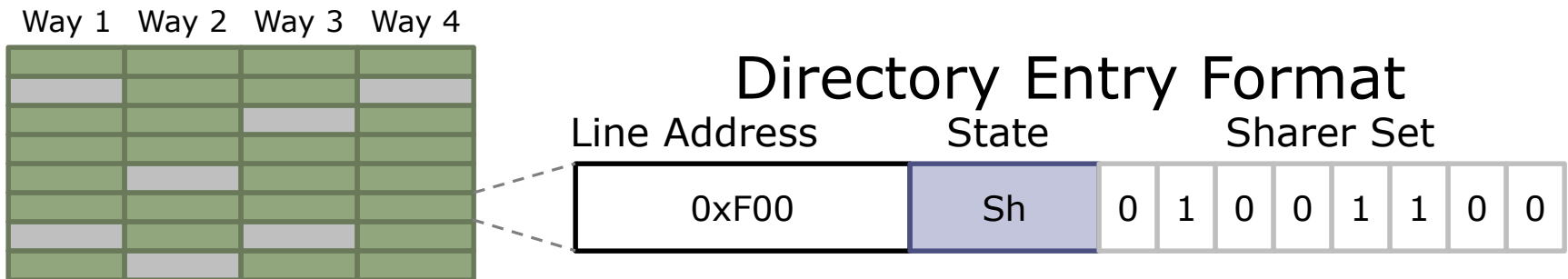

Sparse Full-Map Directories

- Not every line in the system needs to be tracked – only those in private caches!
- Idea: Organize directory as a cache

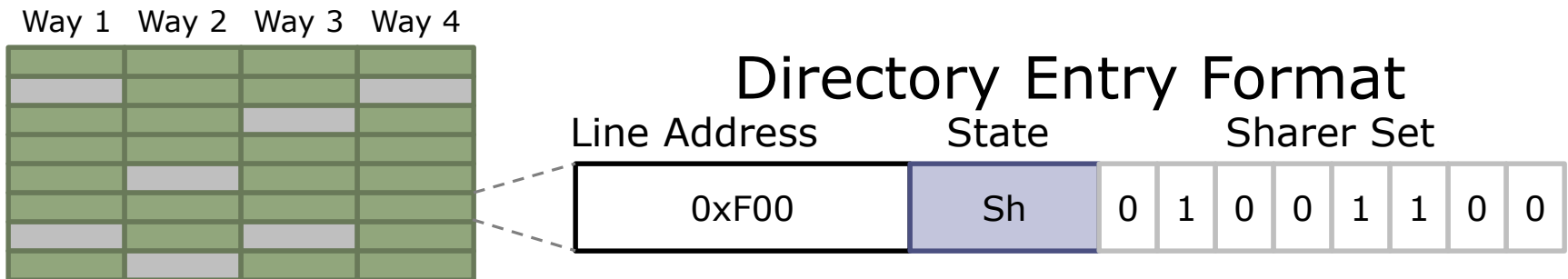

- ✓ Low latency, energy-efficient
- ✗ Bit-vectors grow with # cores → Area scales poorly
- ✗ Limited associativity → Directory-induced invalidations

Directory-Induced Invalidations

- To retain inclusion, must invalidate all sharers of an entry before reusing it for another address
- Example: 2-way set-associative sparse directory

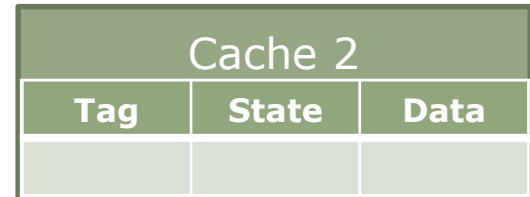
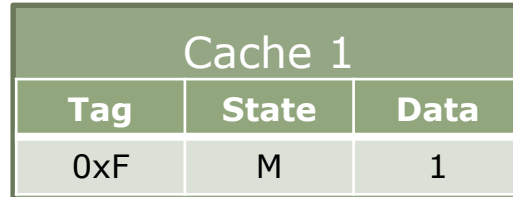
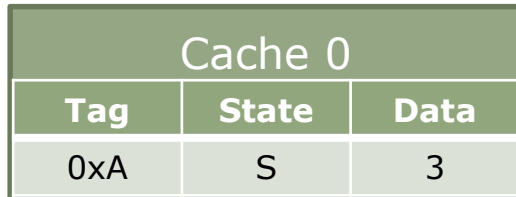
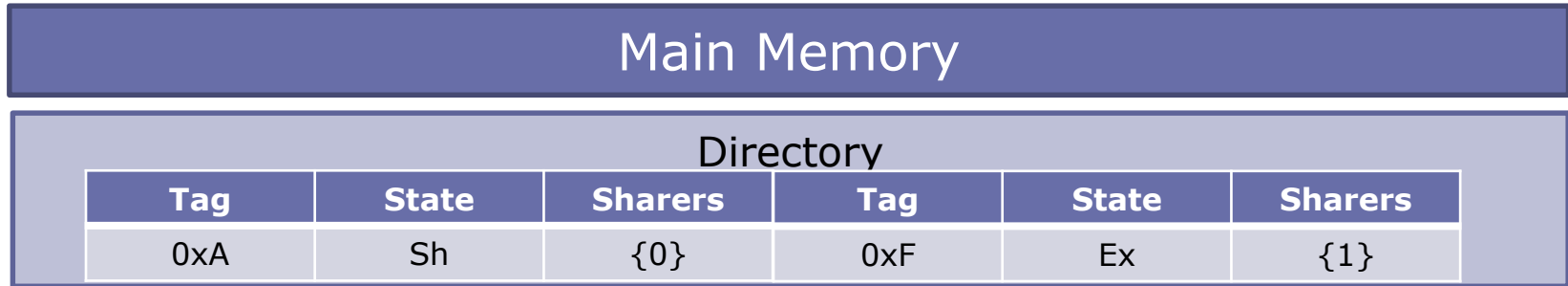

Directory-Induced Invalidations

- To retain inclusion, must invalidate all sharers of an entry before reusing it for another address
- Example: 2-way set-associative sparse directory

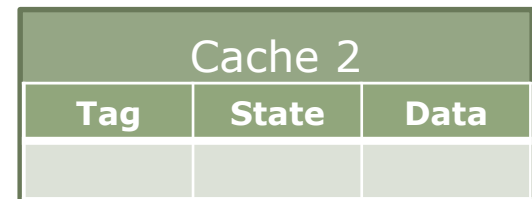
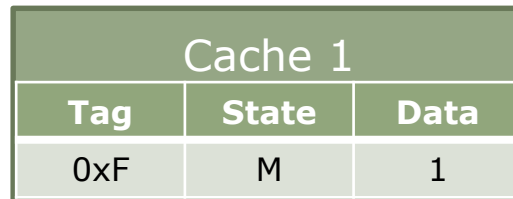
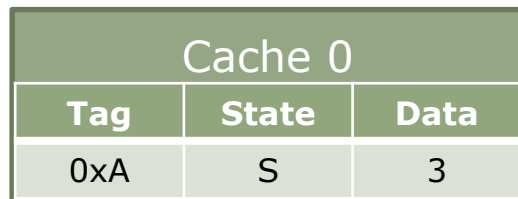
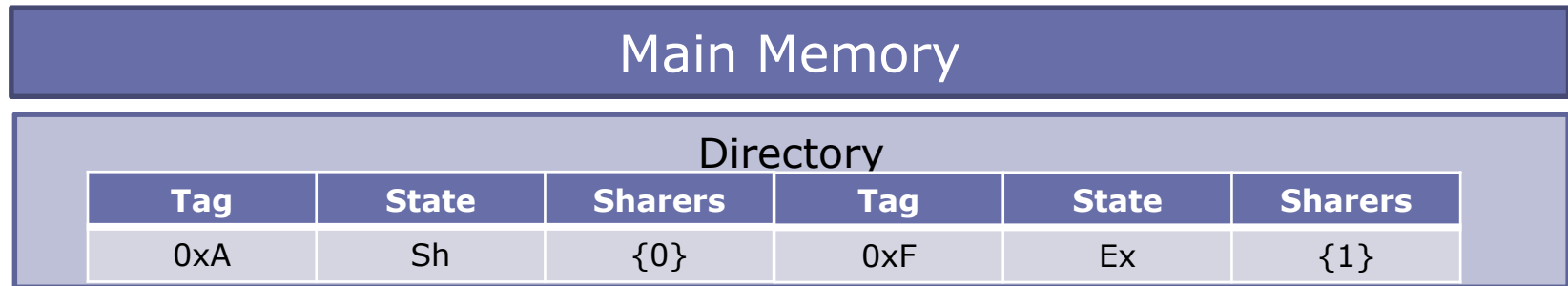

1 LD 0xB

Directory-Induced Invalidations

- To retain inclusion, must invalidate all sharers of an entry before reusing it for another address
- Example: 2-way set-associative sparse directory

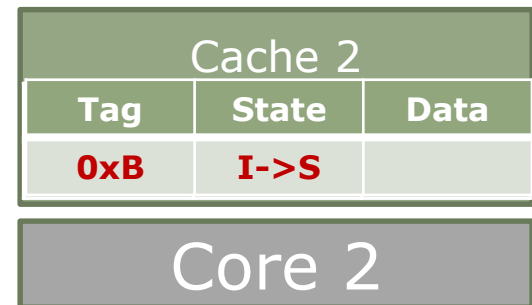
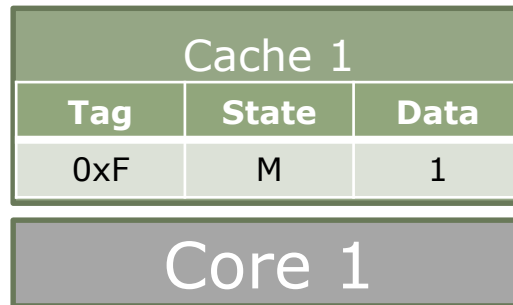
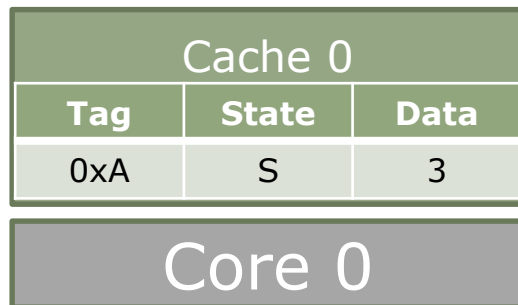
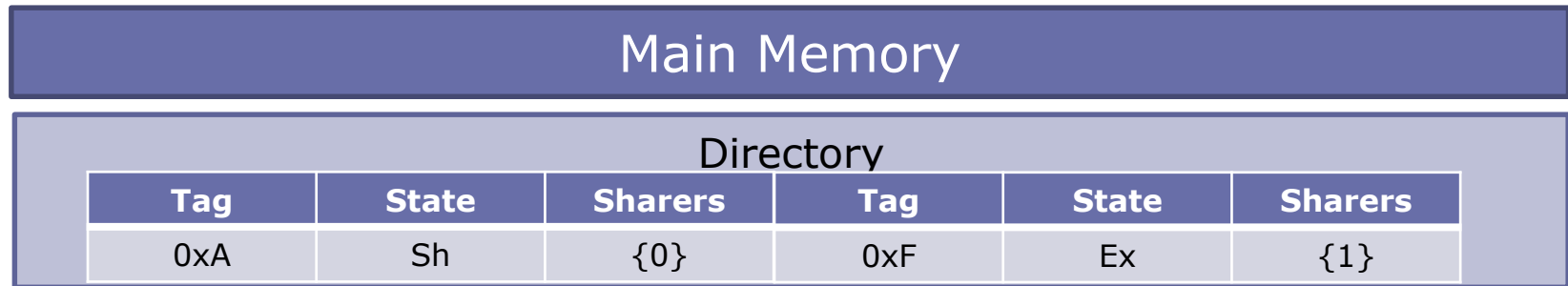

1 LD 0xB

Directory-Induced Invalidations

- To retain inclusion, must invalidate all sharers of an entry before reusing it for another address
- Example: 2-way set-associative sparse directory

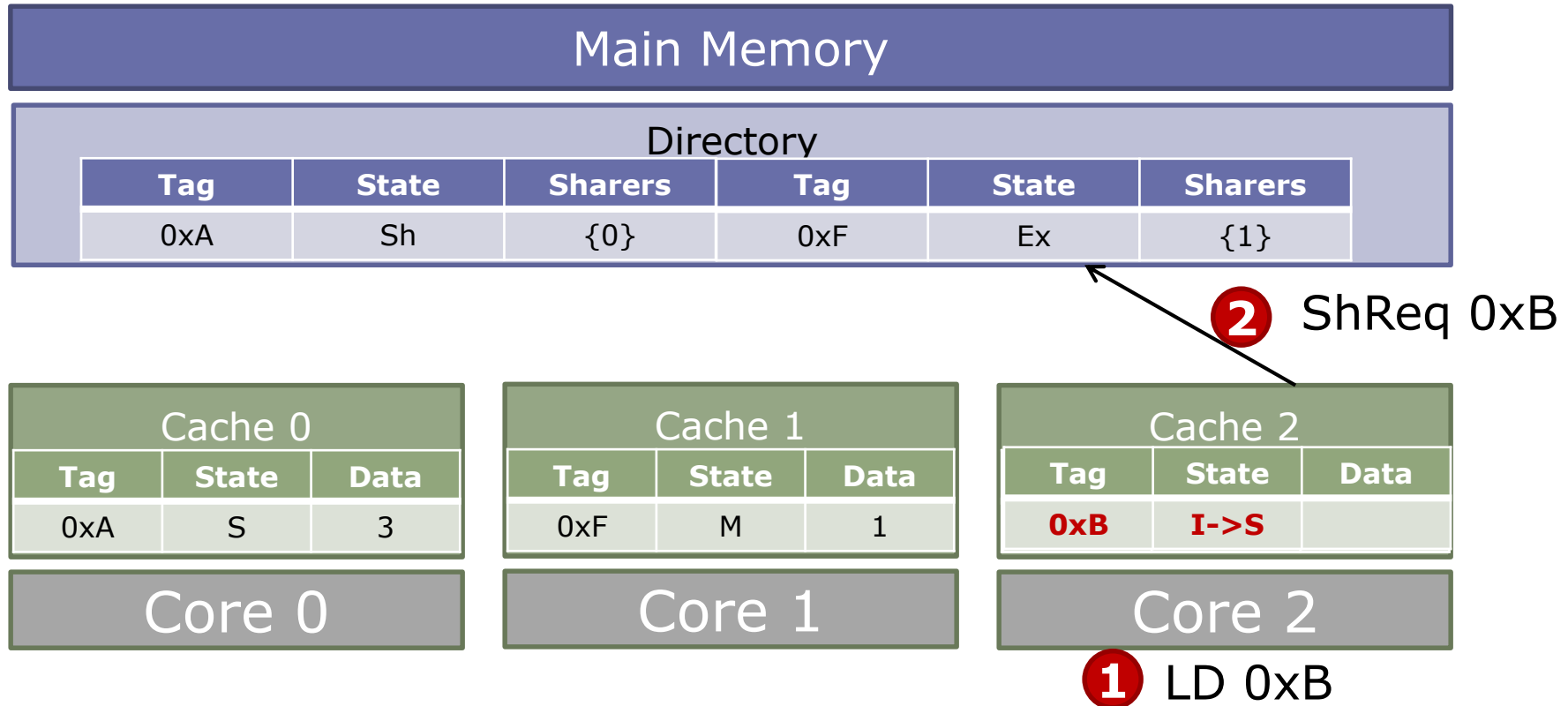

Directory-Induced Invalidations

- To retain inclusion, must invalidate all sharers of an entry before reusing it for another address
- Example: 2-way set-associative sparse directory

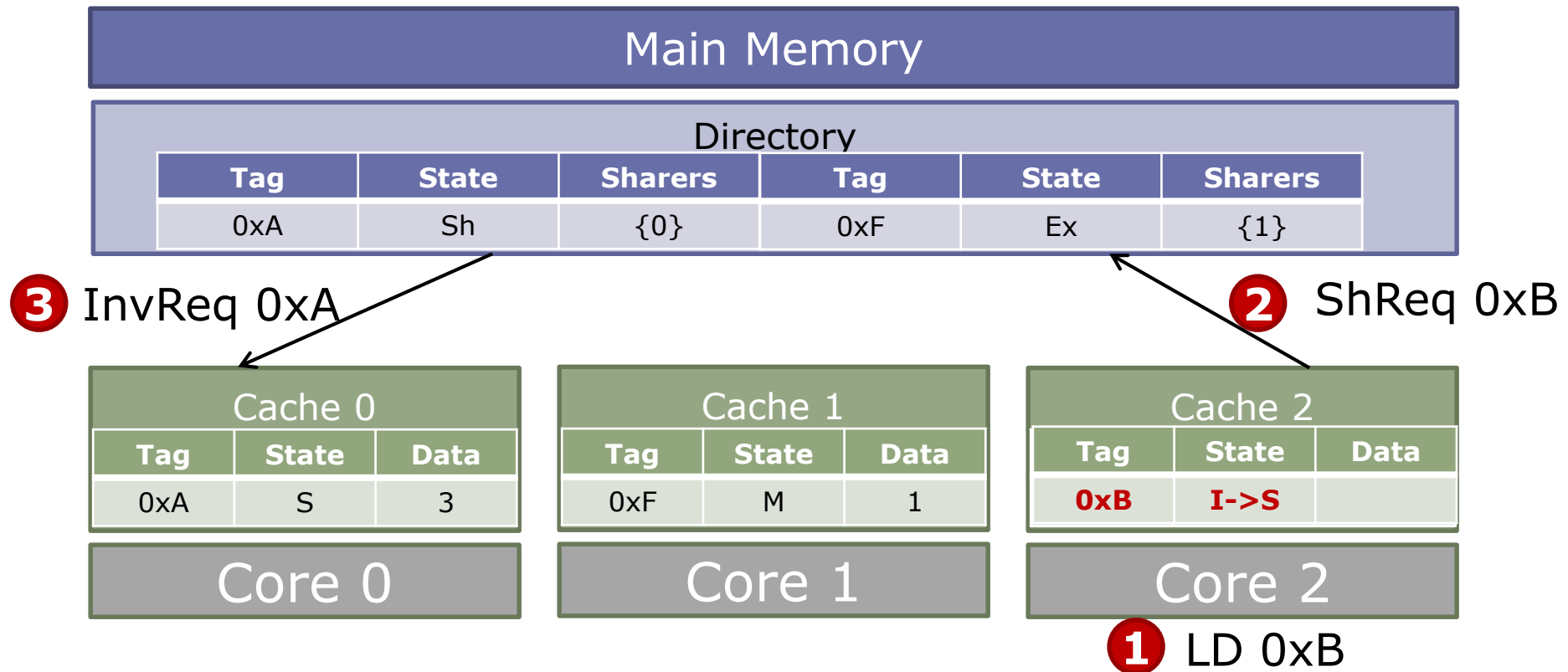

Directory-Induced Invalidations

- To retain inclusion, must invalidate all sharers of an entry before reusing it for another address
- Example: 2-way set-associative sparse directory

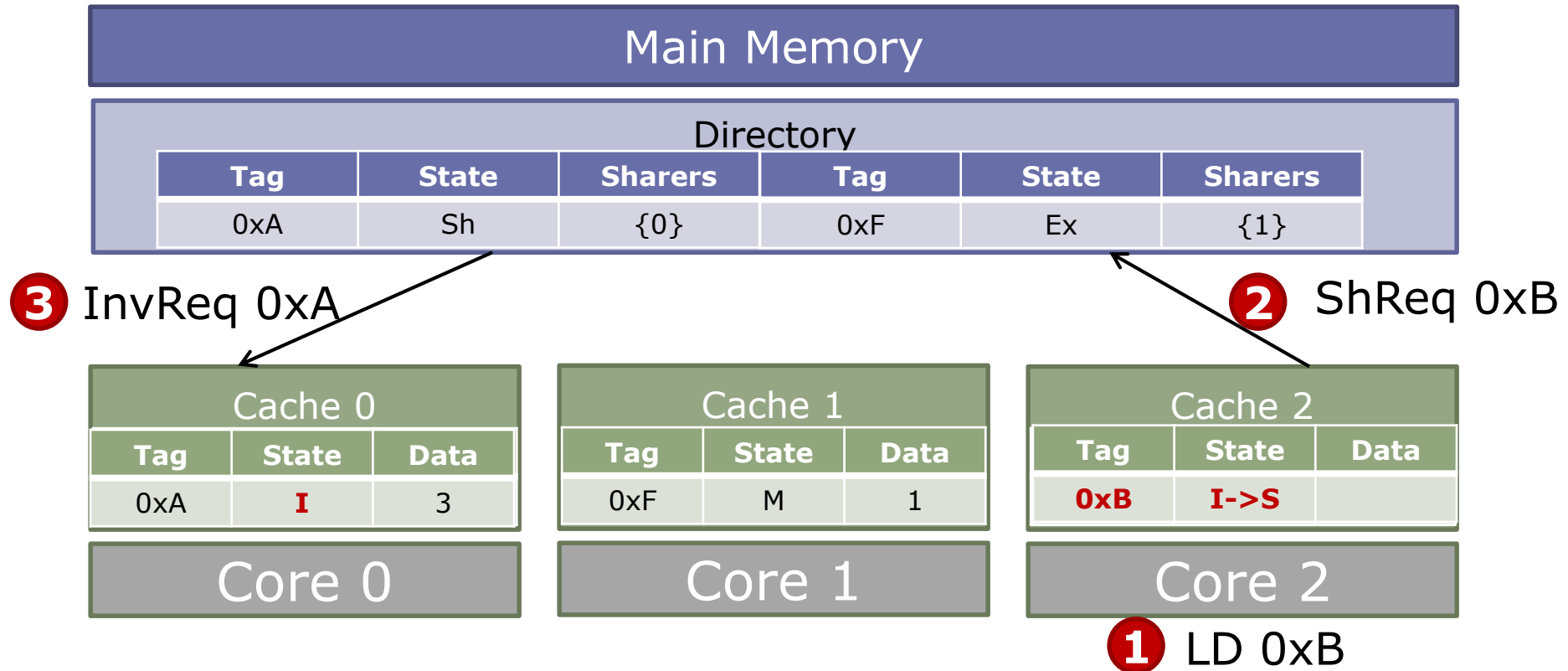

Directory-Induced Invalidations

- To retain inclusion, must invalidate all sharers of an entry before reusing it for another address
- Example: 2-way set-associative sparse directory

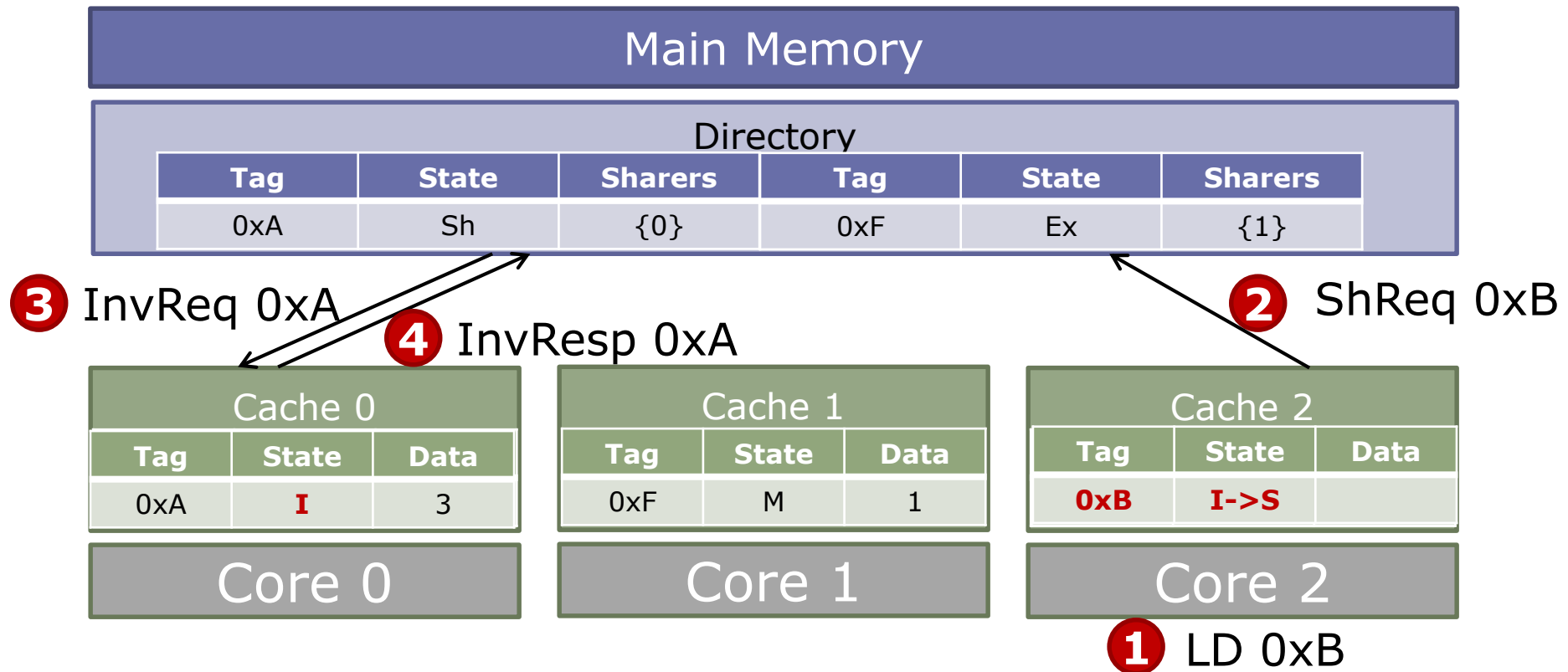

Directory-Induced Invalidations

- To retain inclusion, must invalidate all sharers of an entry before reusing it for another address
- Example: 2-way set-associative sparse directory

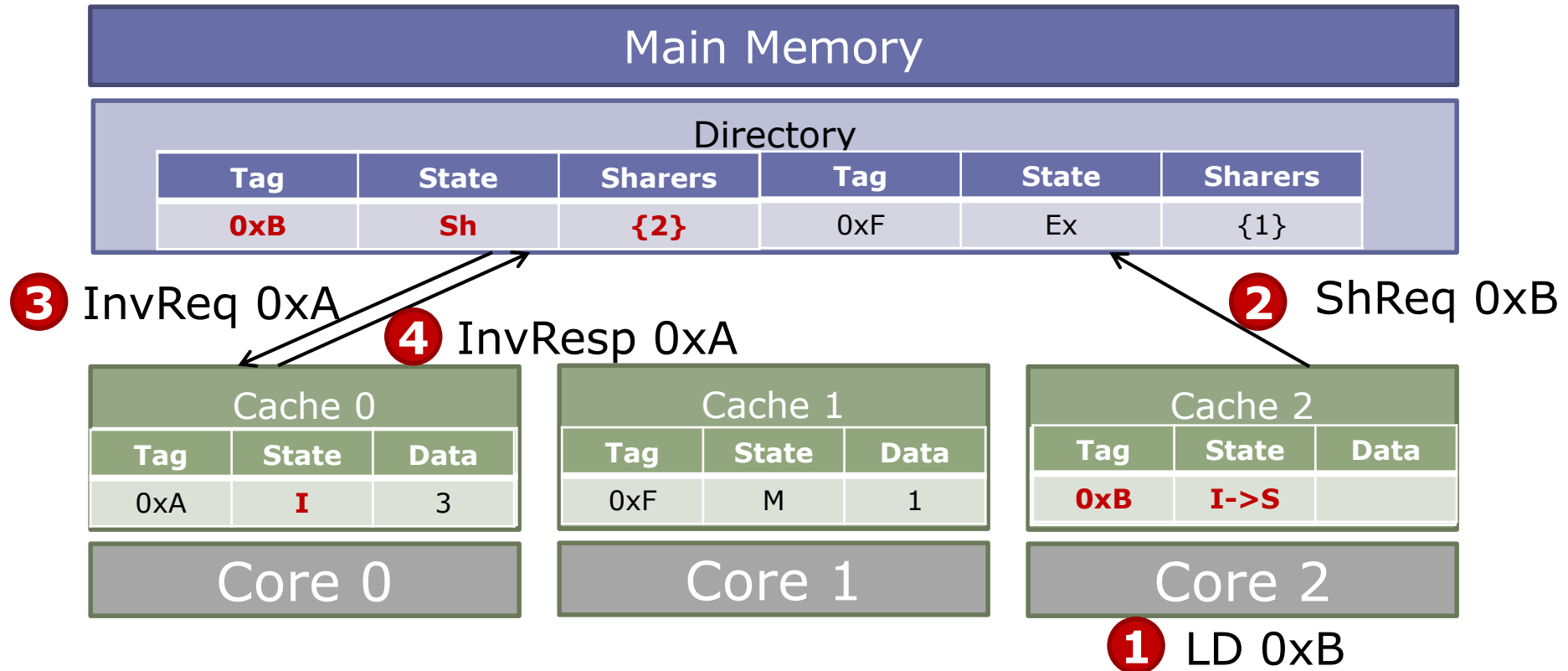

Directory-Induced Invalidations

- To retain inclusion, must invalidate all sharers of an entry before reusing it for another address
- Example: 2-way set-associative sparse directory

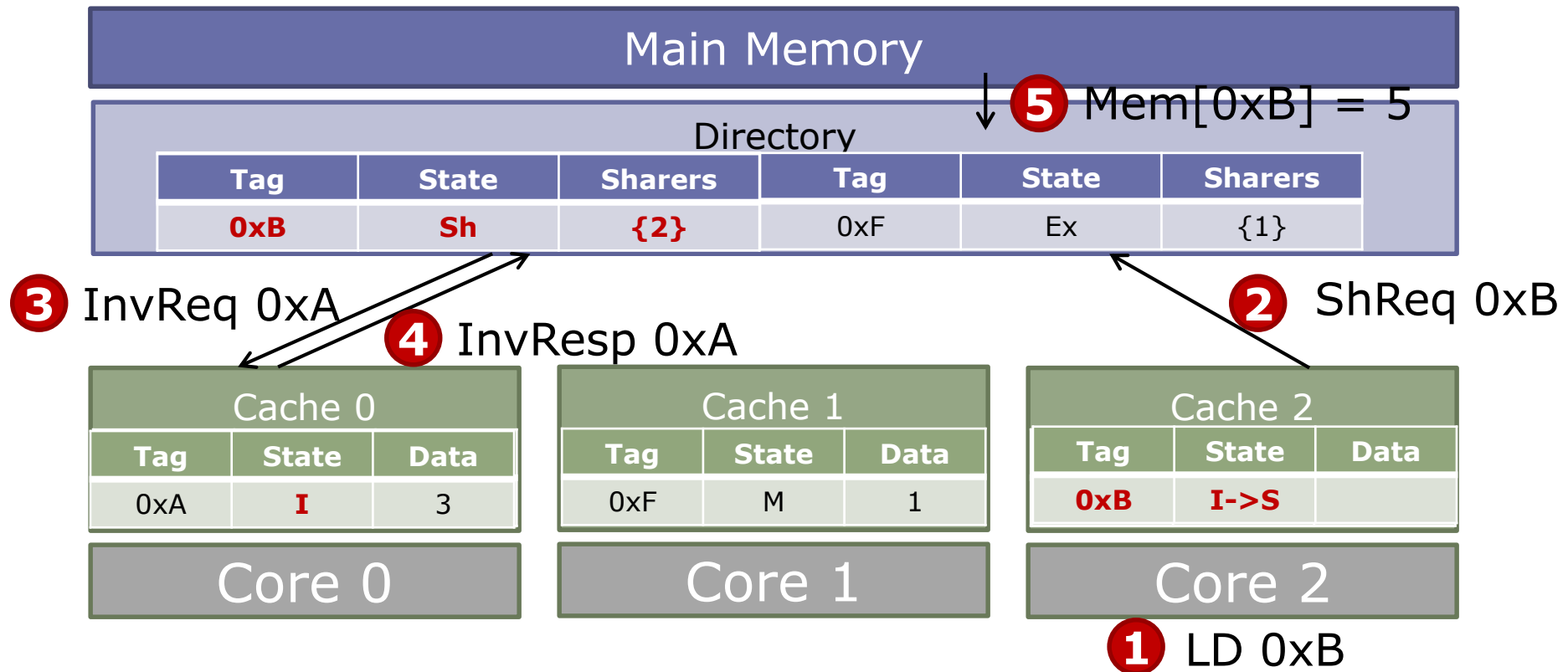

Directory-Induced Invalidations

- To retain inclusion, must invalidate all sharers of an entry before reusing it for another address
- Example: 2-way set-associative sparse directory

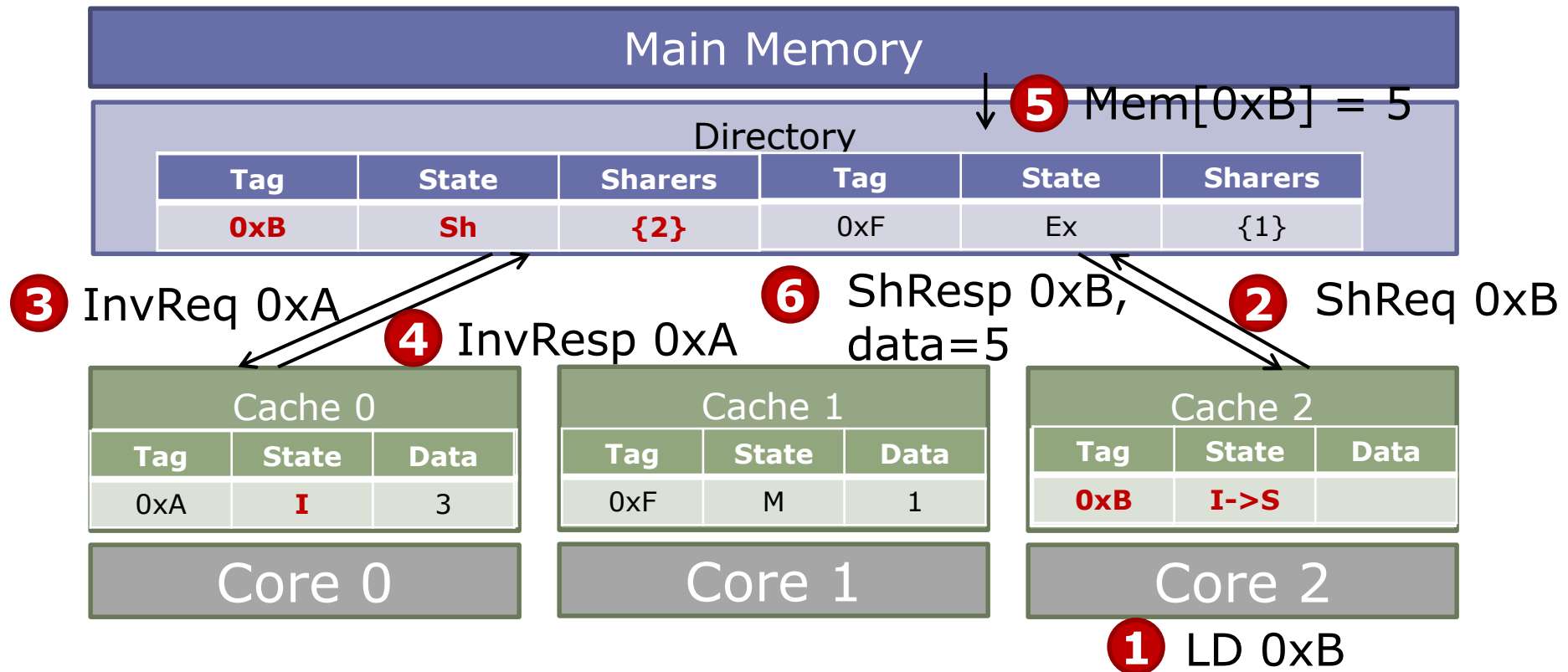

Directory-Induced Invalidations

- To retain inclusion, must invalidate all sharers of an entry before reusing it for another address
- Example: 2-way set-associative sparse directory

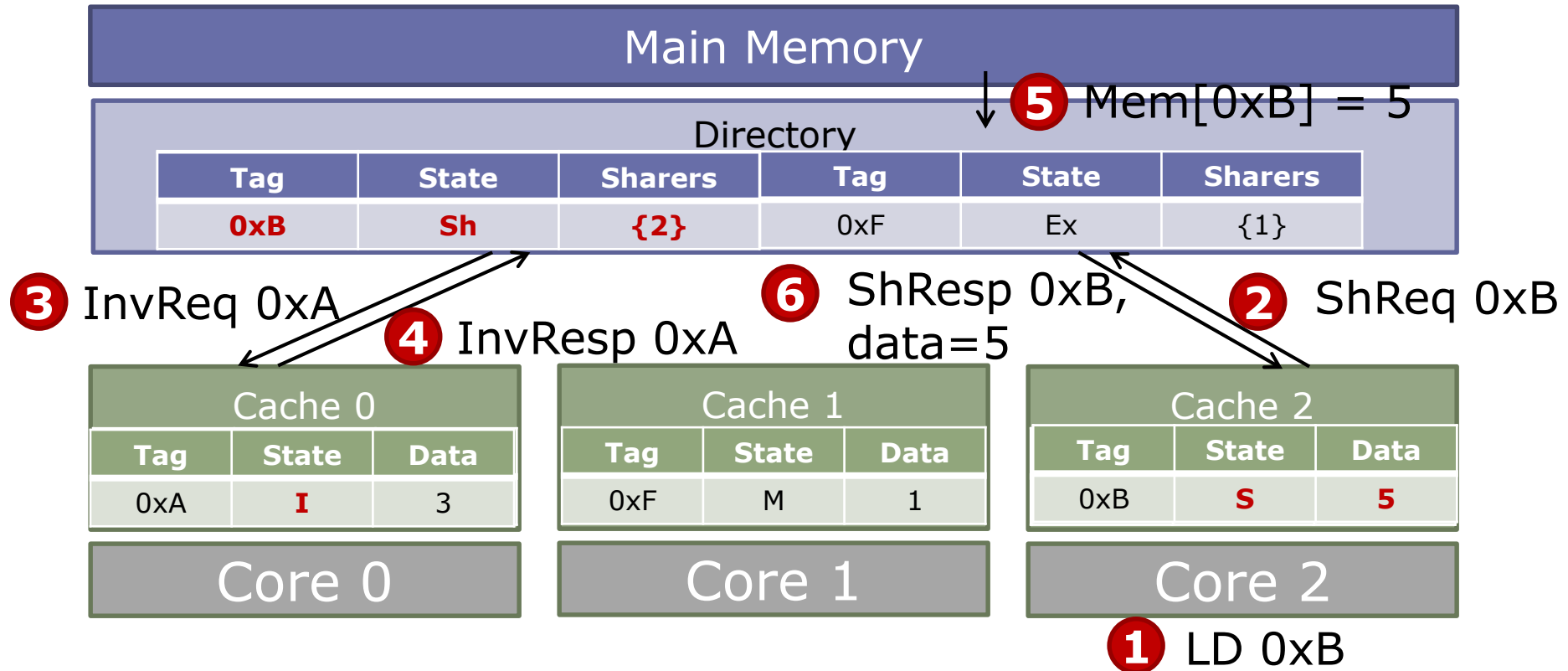

Directory-Induced Invalidations

- To retain inclusion, must invalidate all sharers of an entry before reusing it for another address
- Example: 2-way set-associative sparse directory

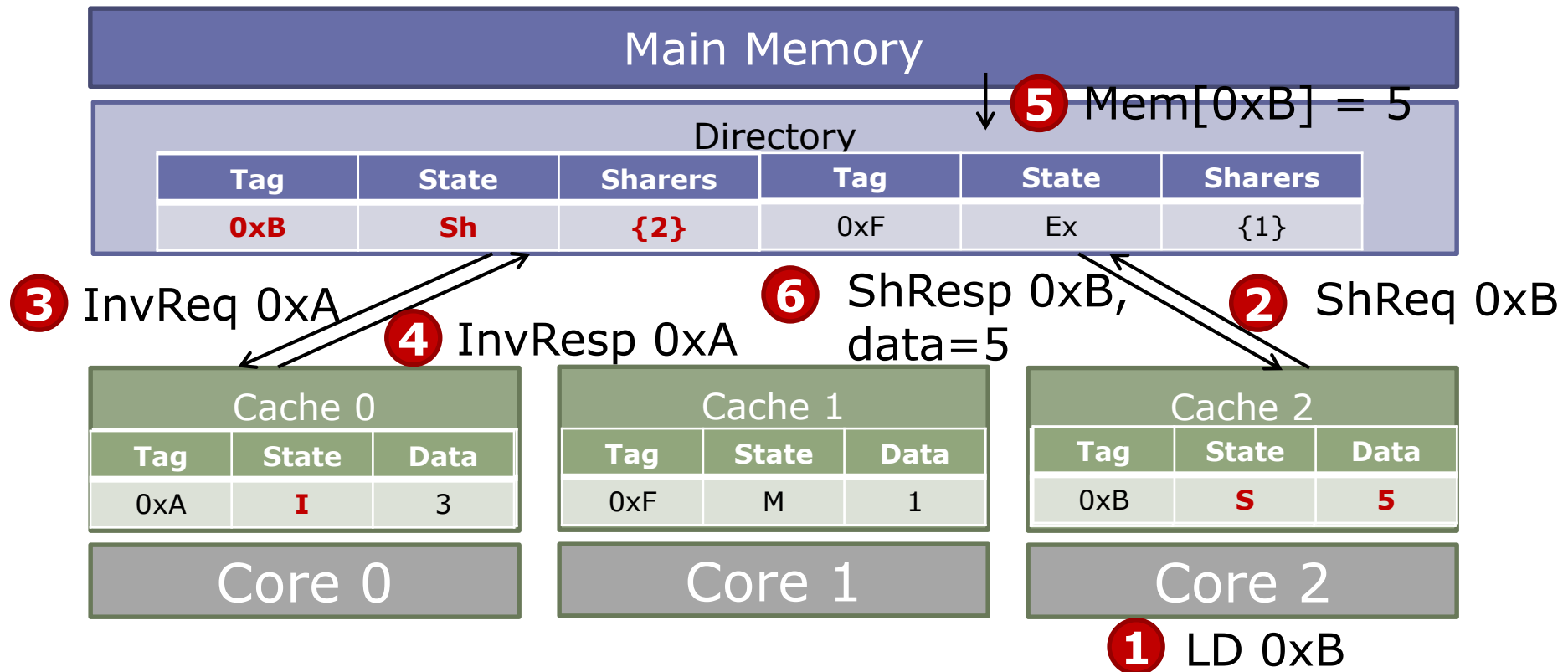

How many entries should the directory have?

Inexact Representations of Sharer Sets

- Coarse-grain bit-vectors (e.g., 1 bit per 4 cores)

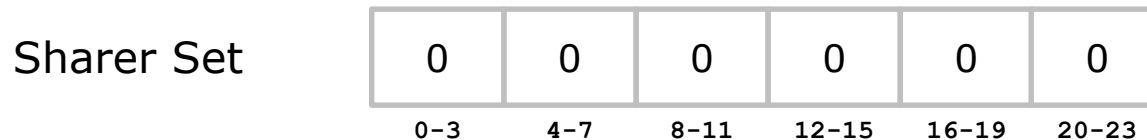

- Limited pointers: Maintain a few sharer pointers, on overflow mark 'all' and broadcast (or invalidate another sharer)

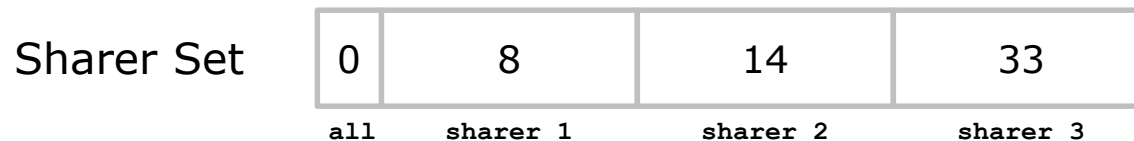

- Allow false positives (e.g., Bloom filters)

Inexact Representations of Sharer Sets

- Coarse-grain bit-vectors (e.g., 1 bit per 4 cores)

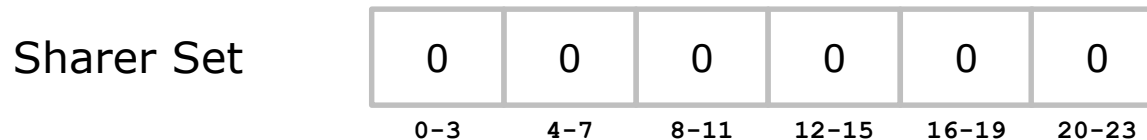

- Limited pointers: Maintain a few sharer pointers, on overflow mark 'all' and broadcast (or invalidate another sharer)

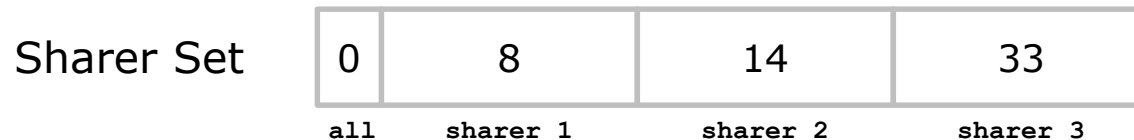

- Allow false positives (e.g., Bloom filters)
 - ✓ Reduced area & energy
 - ✗ Overheads still not scalable (these techniques simply play with constant factors)
 - ✗ Inexact sharers → Broadcasts, invalidations or spurious invalidations and downgrades

Protocol Races

- Directory serializes multiple requests for the same address
 - Same-address requests are queued or NACKed and retried
- But races still exist due to conflicting requests
- Example: Upgrade race

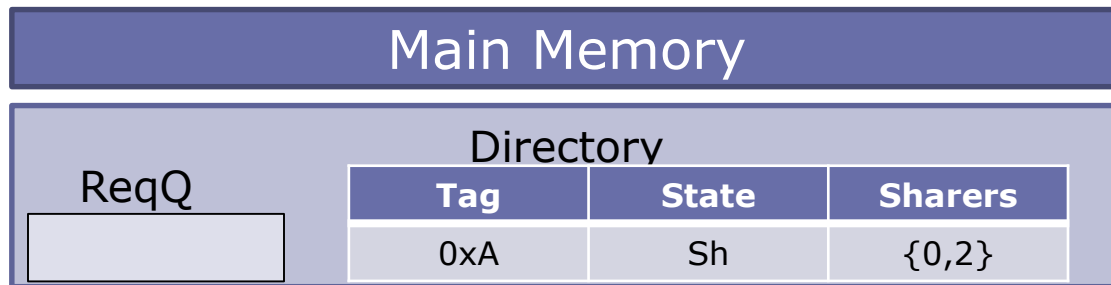

Cache 0		
Tag	State	Data
0xA	S	3

Core 0

Cache 1		
Tag	State	Data
0xA	S	3

Core 1

Protocol Races

- Directory serializes multiple requests for the same address
 - Same-address requests are queued or NACKed and retried
- But races still exist due to conflicting requests
- Example: Upgrade race

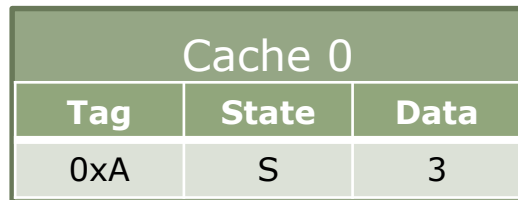
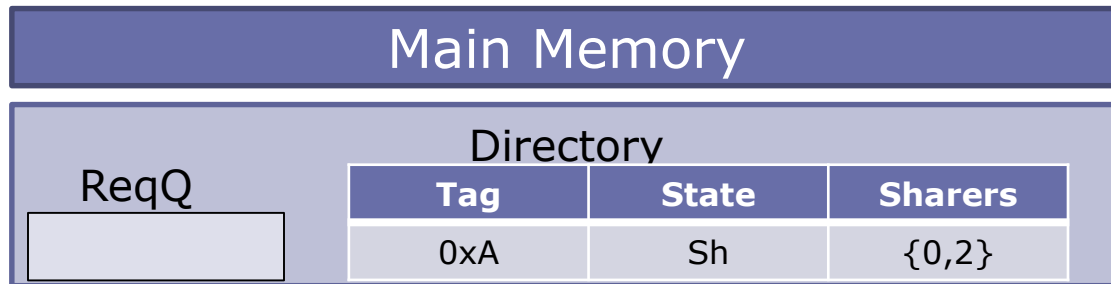

1 ST 0xA

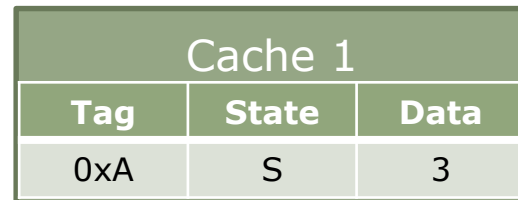

1' ST 0xA

Protocol Races

- Directory serializes multiple requests for the same address
 - Same-address requests are queued or NACKed and retried
- But races still exist due to conflicting requests
- Example: Upgrade race

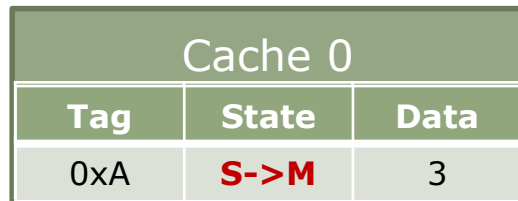
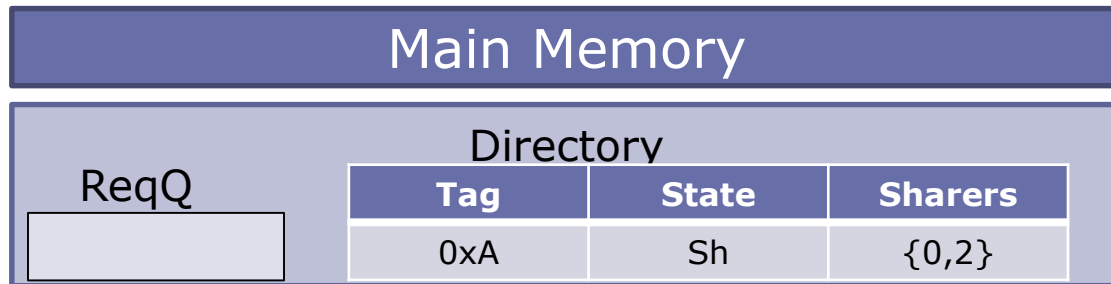

1 ST 0xA

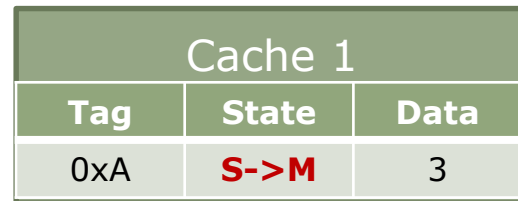

1' ST 0xA

Protocol Races

- Directory serializes multiple requests for the same address
 - Same-address requests are queued or NACKed and retried
- But races still exist due to conflicting requests
- Example: Upgrade race

Caches 0 and 1 issue simultaneous ExReqs

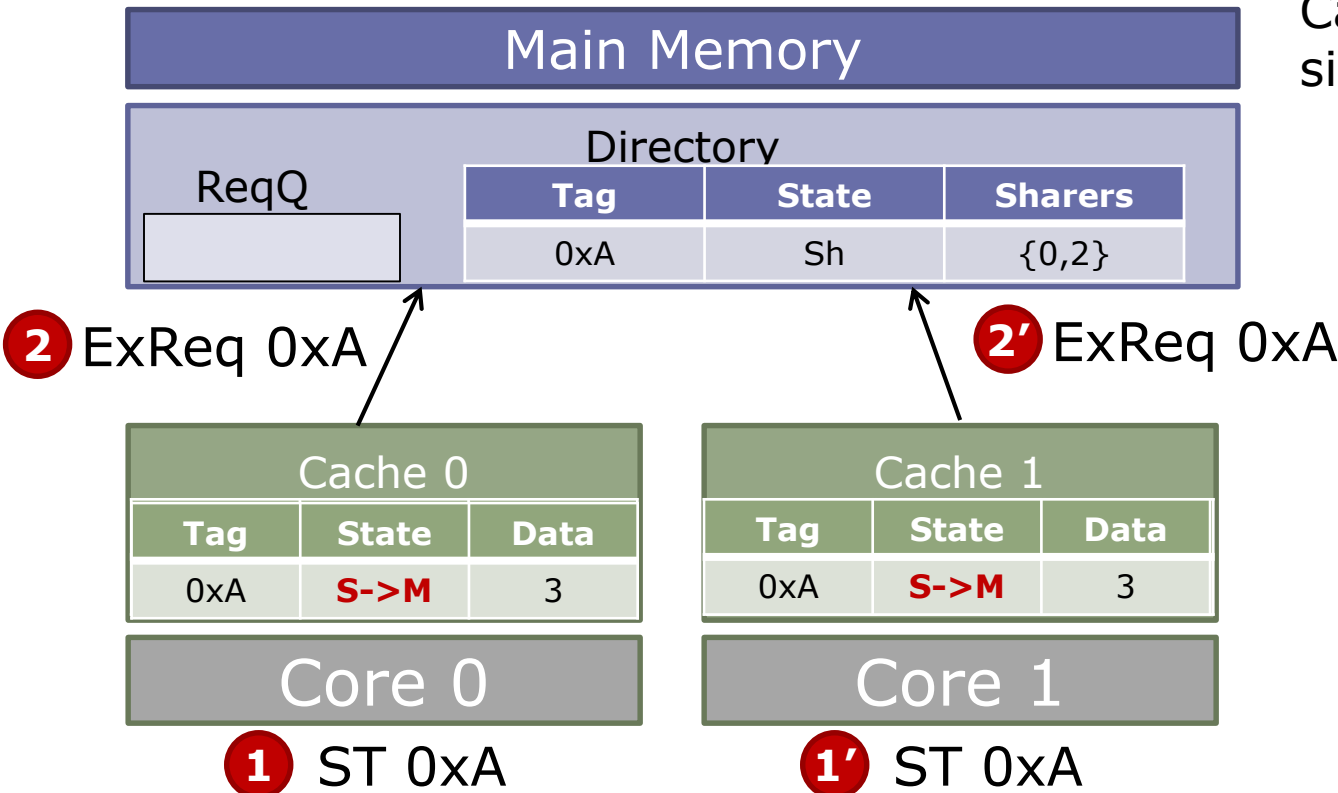

Protocol Races

- Directory serializes multiple requests for the same address
 - Same-address requests are queued or NACKed and retried
- But races still exist due to conflicting requests
- Example: Upgrade race

Caches 0 and 1 issue simultaneous ExReqs
 Directory starts serving cache 0's ExReq,
 queues cache 1's

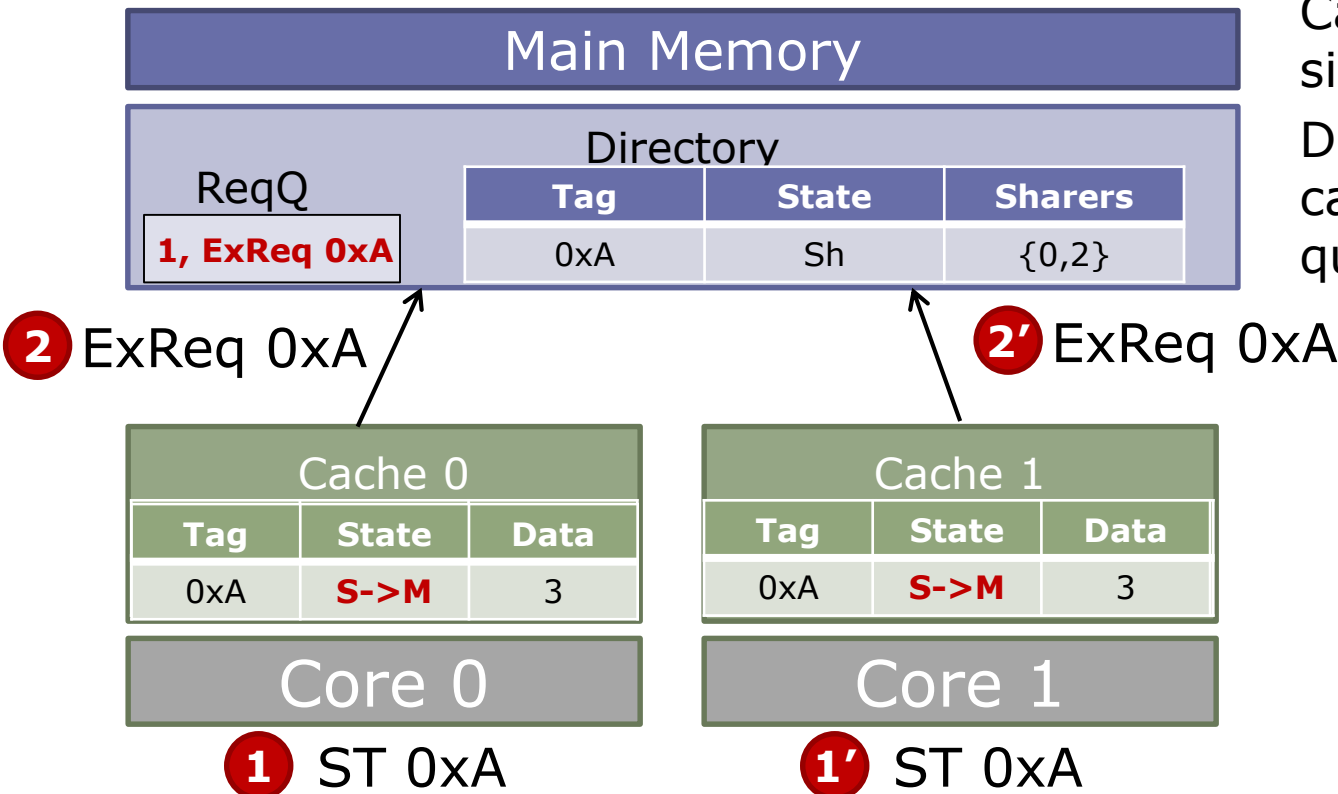

Protocol Races

- Directory serializes multiple requests for the same address
 - Same-address requests are queued or NACKed and retried
- But races still exist due to conflicting requests
- Example: Upgrade race

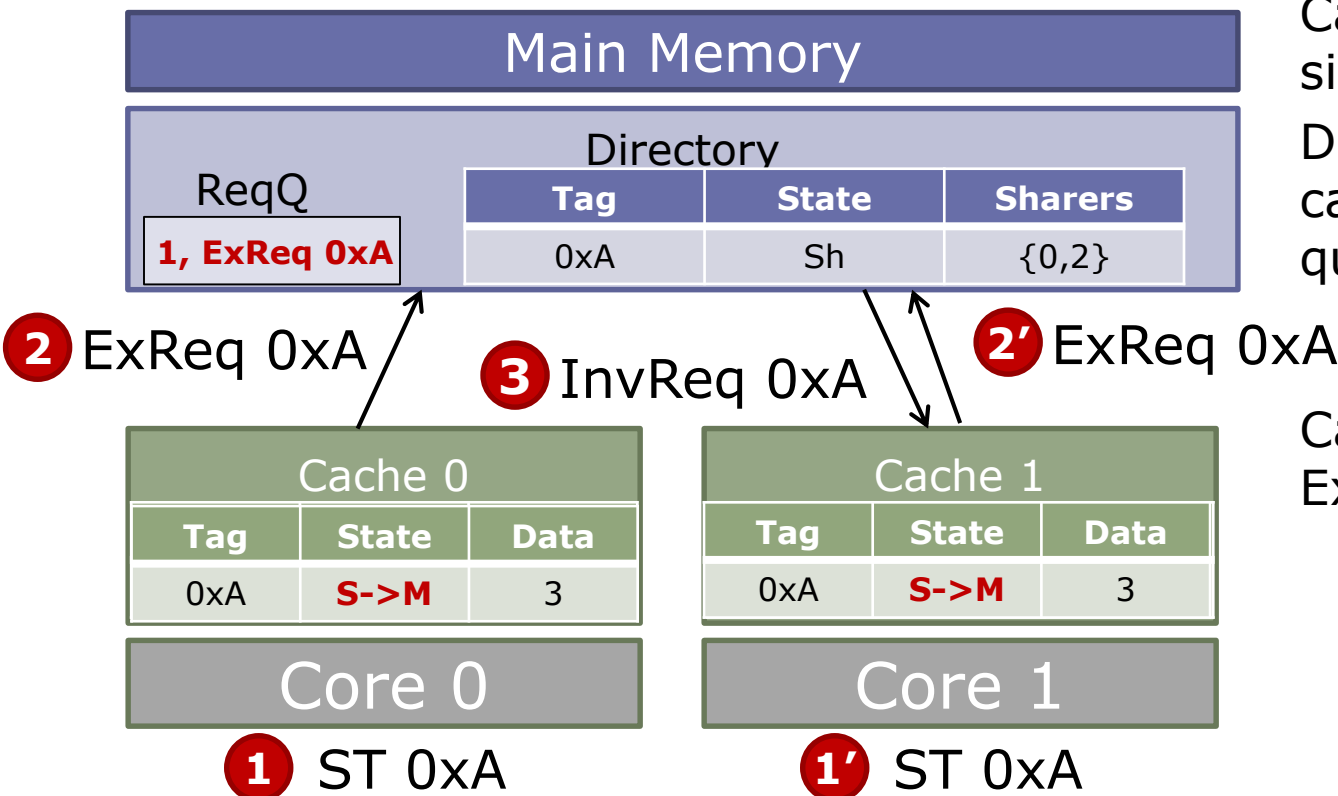

Caches 0 and 1 issue simultaneous ExReqs
 Directory starts serving cache 0's ExReq, queues cache 1's

Cache 1 expected ExResp, but got InvReq!

Protocol Races

- Directory serializes multiple requests for the same address
 - Same-address requests are queued or NACKed and retried
- But races still exist due to conflicting requests
- Example: Upgrade race

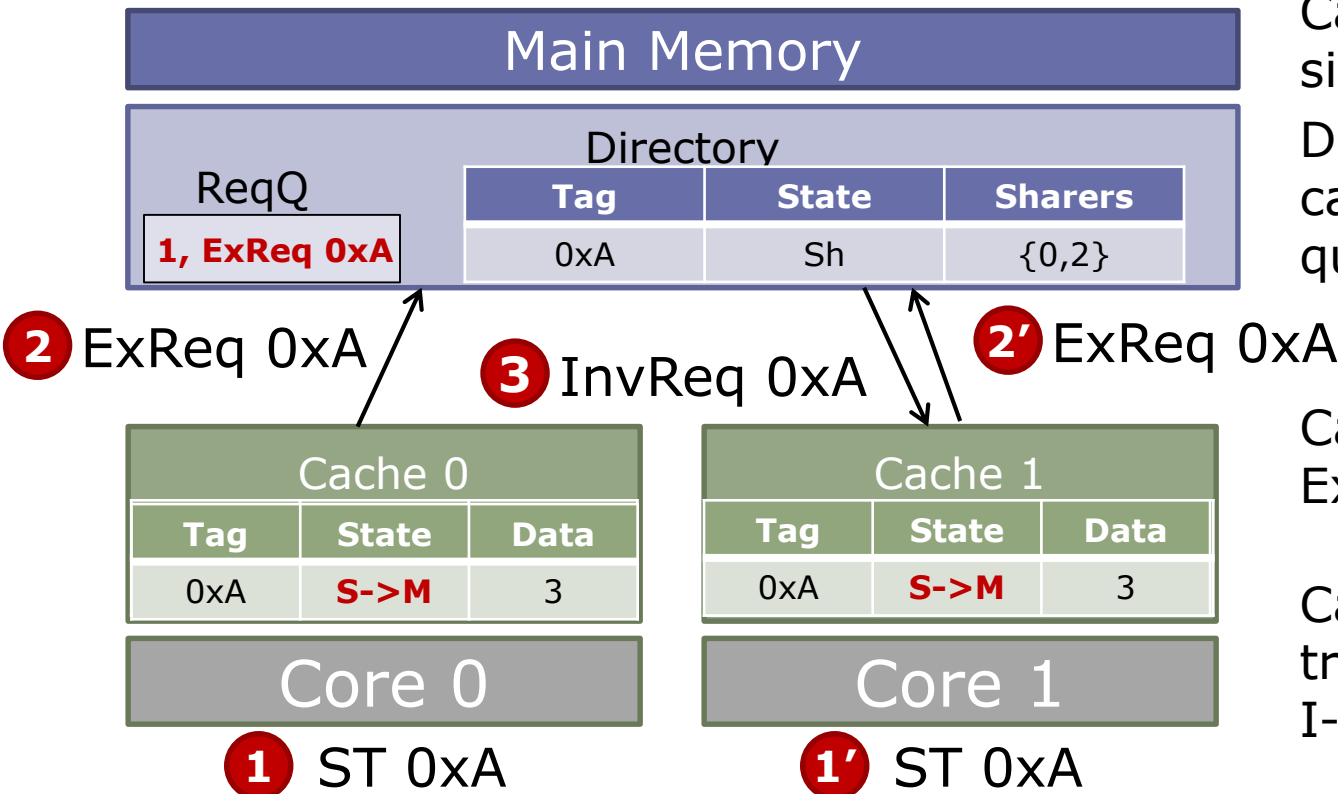

Caches 0 and 1 issue simultaneous ExReqs
 Directory starts serving cache 0's ExReq, queues cache 1's

Cache 1 expected ExResp, but got InvReq!

Cache 1 should transition from S->M to I->M and send InvResp

Extra Hops and 3-Hop Protocols

Reducing Protocol Latency

- Problem: Data in another cache needs to pass through the directory, adding latency
- Optimization: Forward data to requester directly

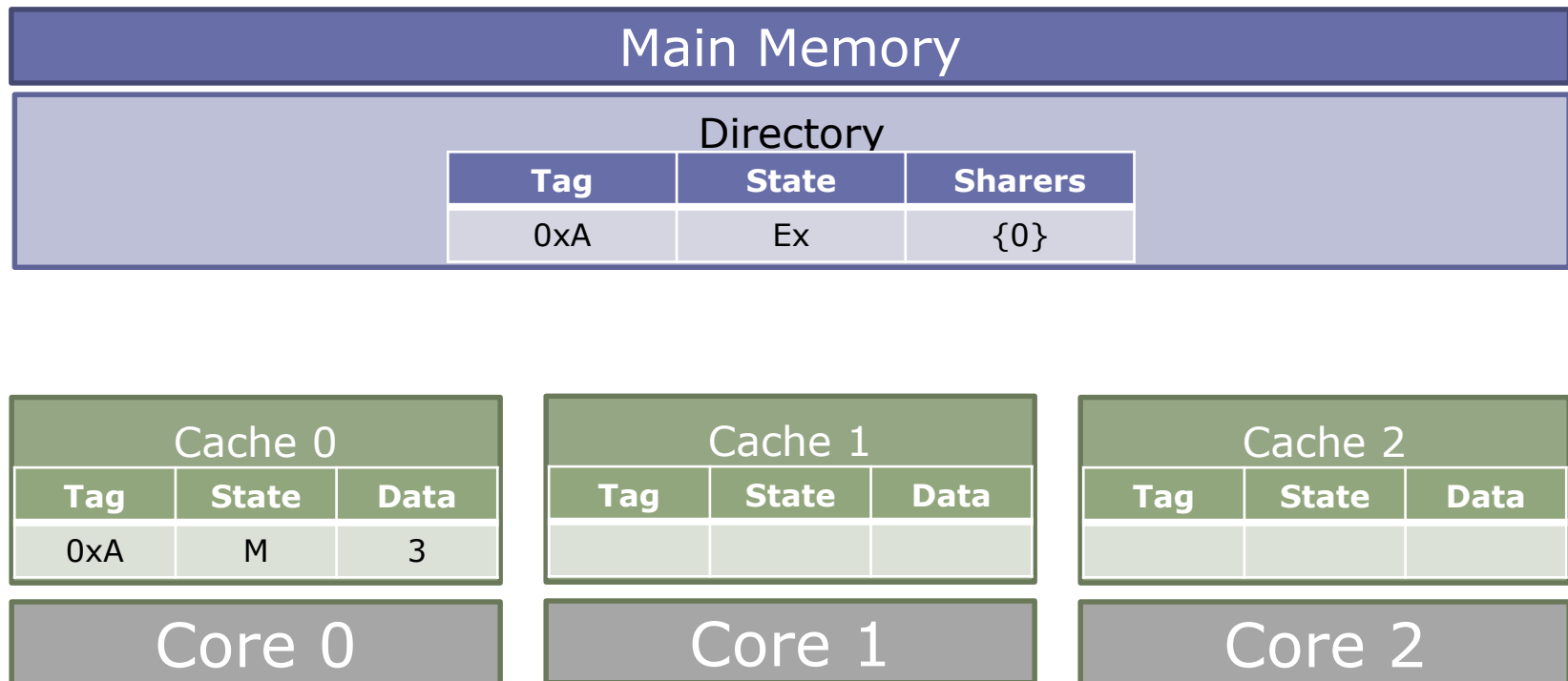

Extra Hops and 3-Hop Protocols

Reducing Protocol Latency

- Problem: Data in another cache needs to pass through the directory, adding latency
- Optimization: Forward data to requester directly

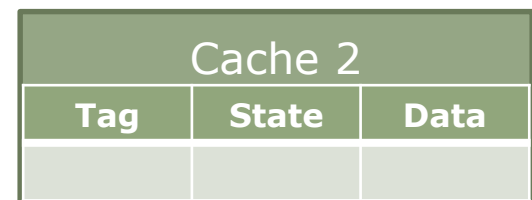
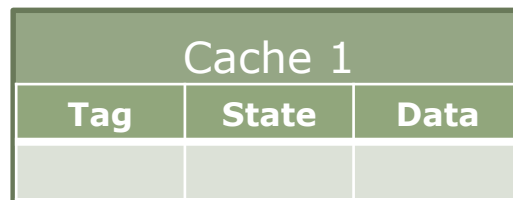
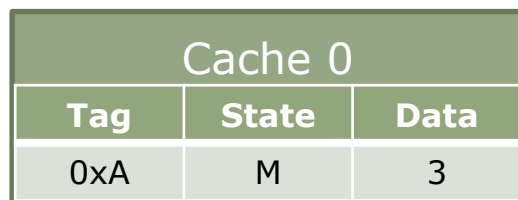
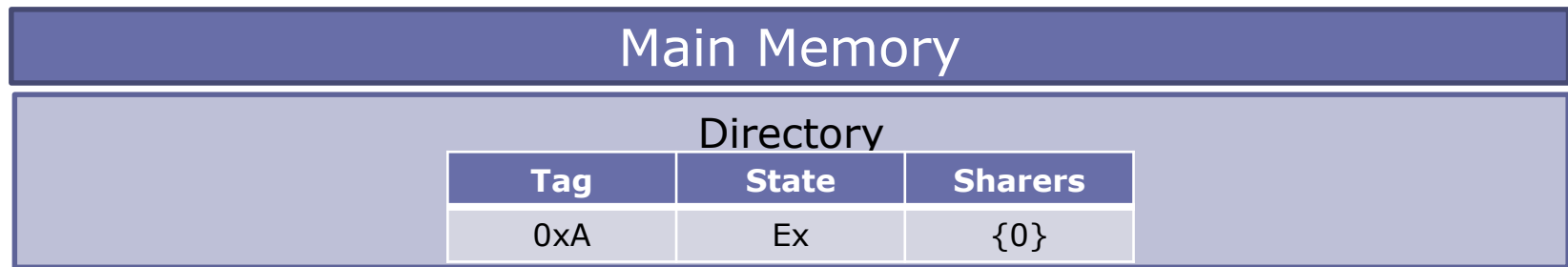

1 ST 0xA

Extra Hops and 3-Hop Protocols

Reducing Protocol Latency

- Problem: Data in another cache needs to pass through the directory, adding latency
- Optimization: Forward data to requester directly

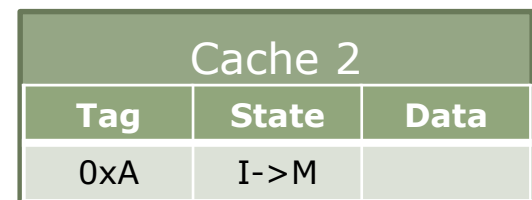
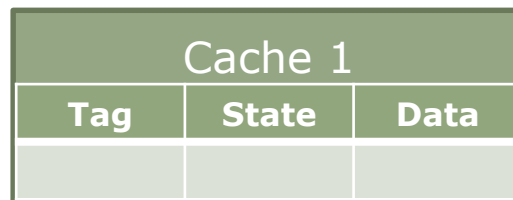
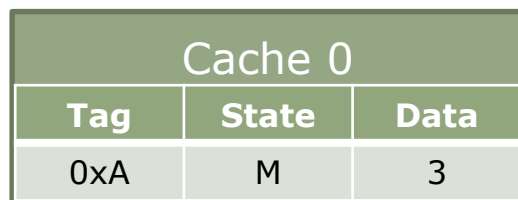
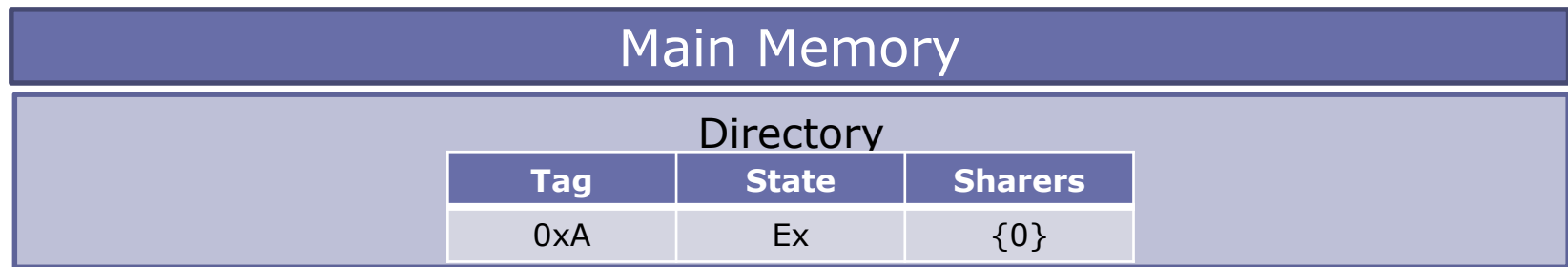

1 ST 0xA

Extra Hops and 3-Hop Protocols

Reducing Protocol Latency

- Problem: Data in another cache needs to pass through the directory, adding latency
- Optimization: Forward data to requester directly

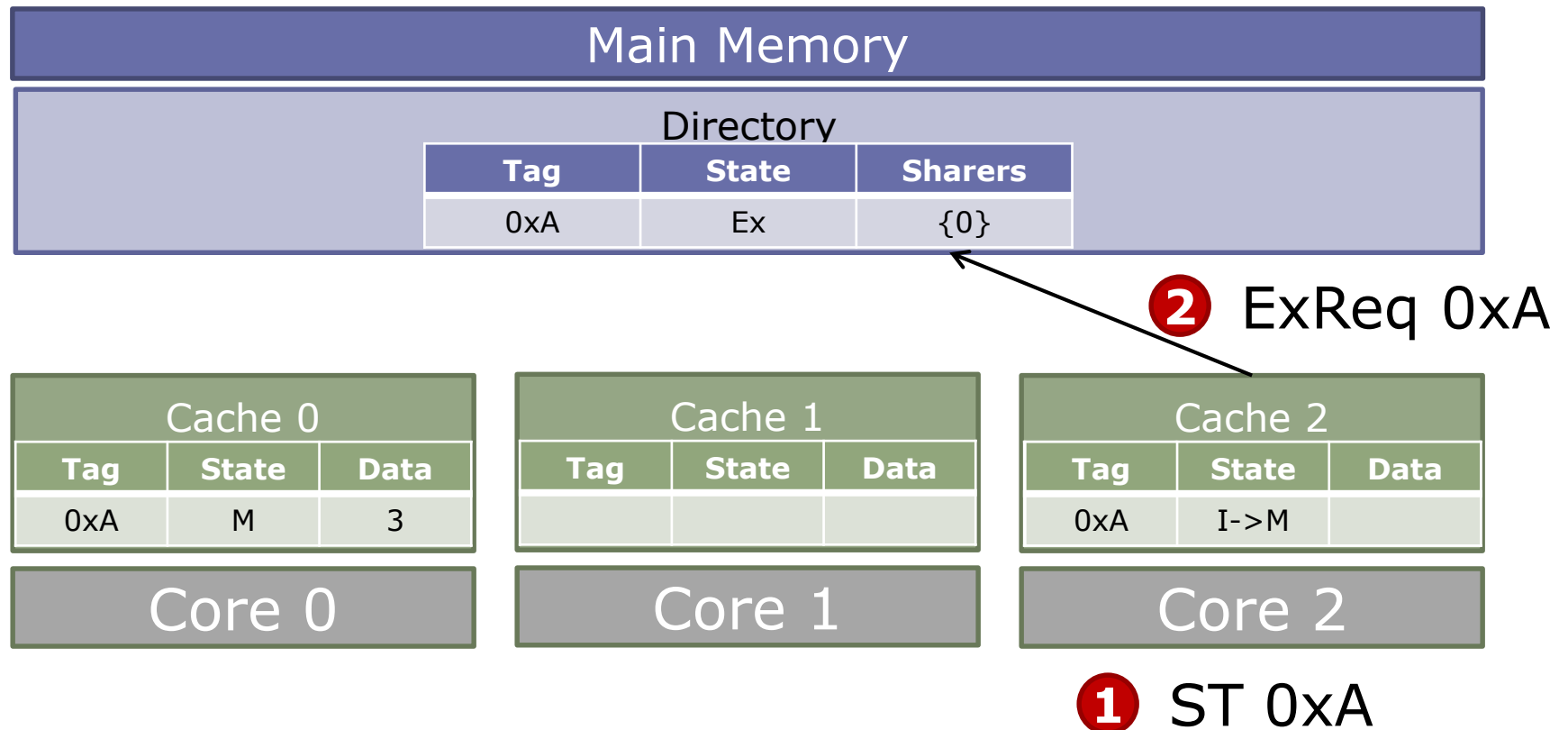

Extra Hops and 3-Hop Protocols

Reducing Protocol Latency

- Problem: Data in another cache needs to pass through the directory, adding latency
- Optimization: Forward data to requester directly

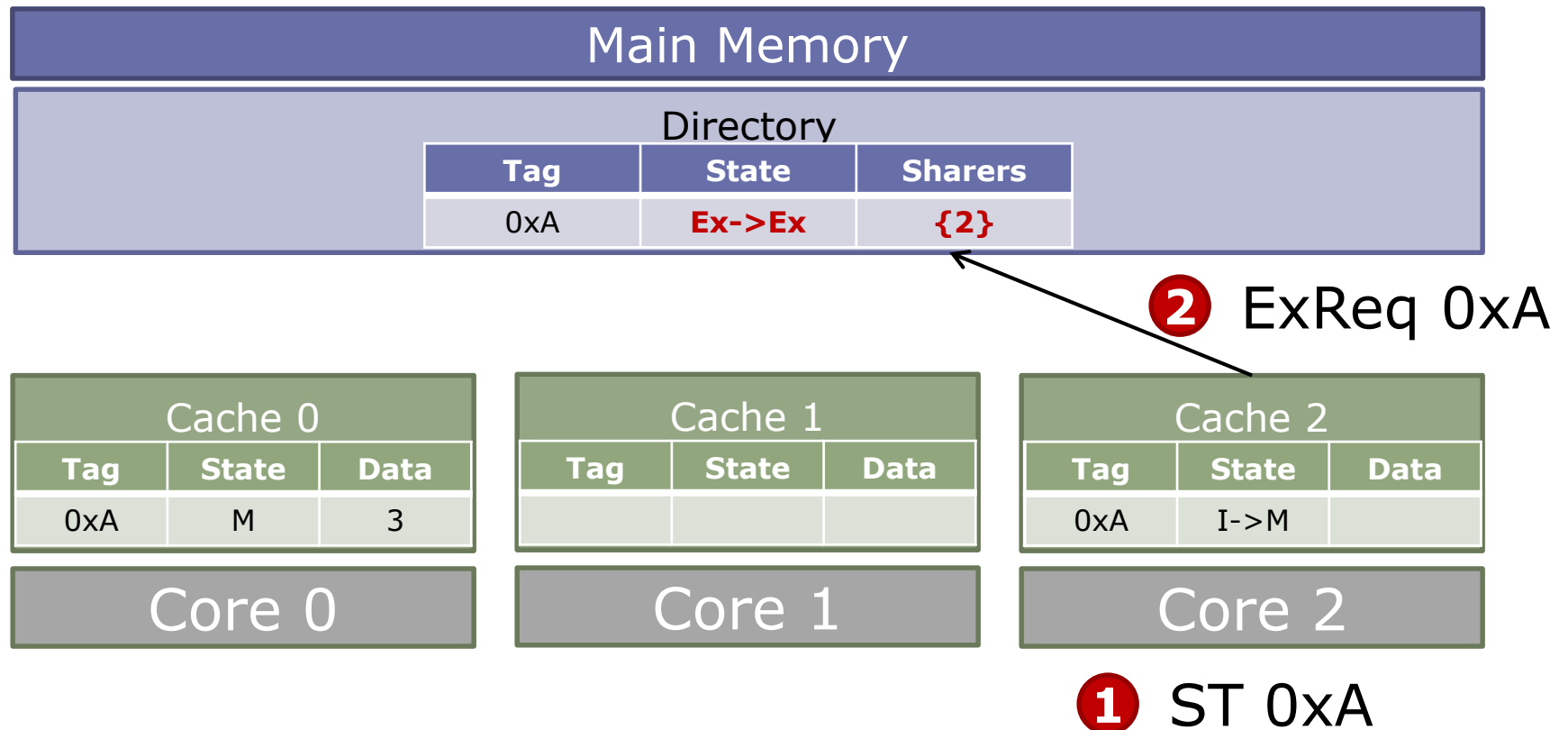

Extra Hops and 3-Hop Protocols

Reducing Protocol Latency

- Problem: Data in another cache needs to pass through the directory, adding latency
- Optimization: Forward data to requester directly

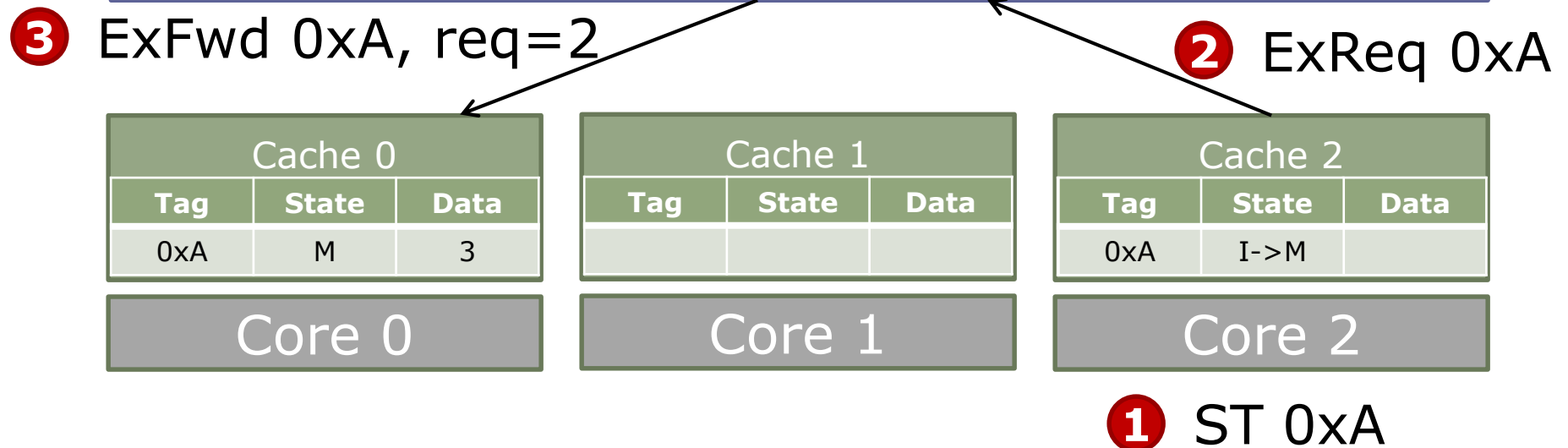
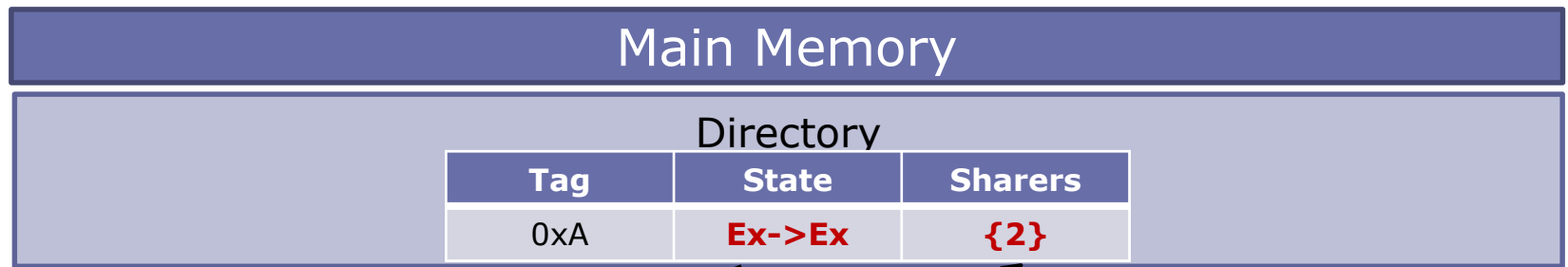

Extra Hops and 3-Hop Protocols

Reducing Protocol Latency

- Problem: Data in another cache needs to pass through the directory, adding latency
- Optimization: Forward data to requester directly

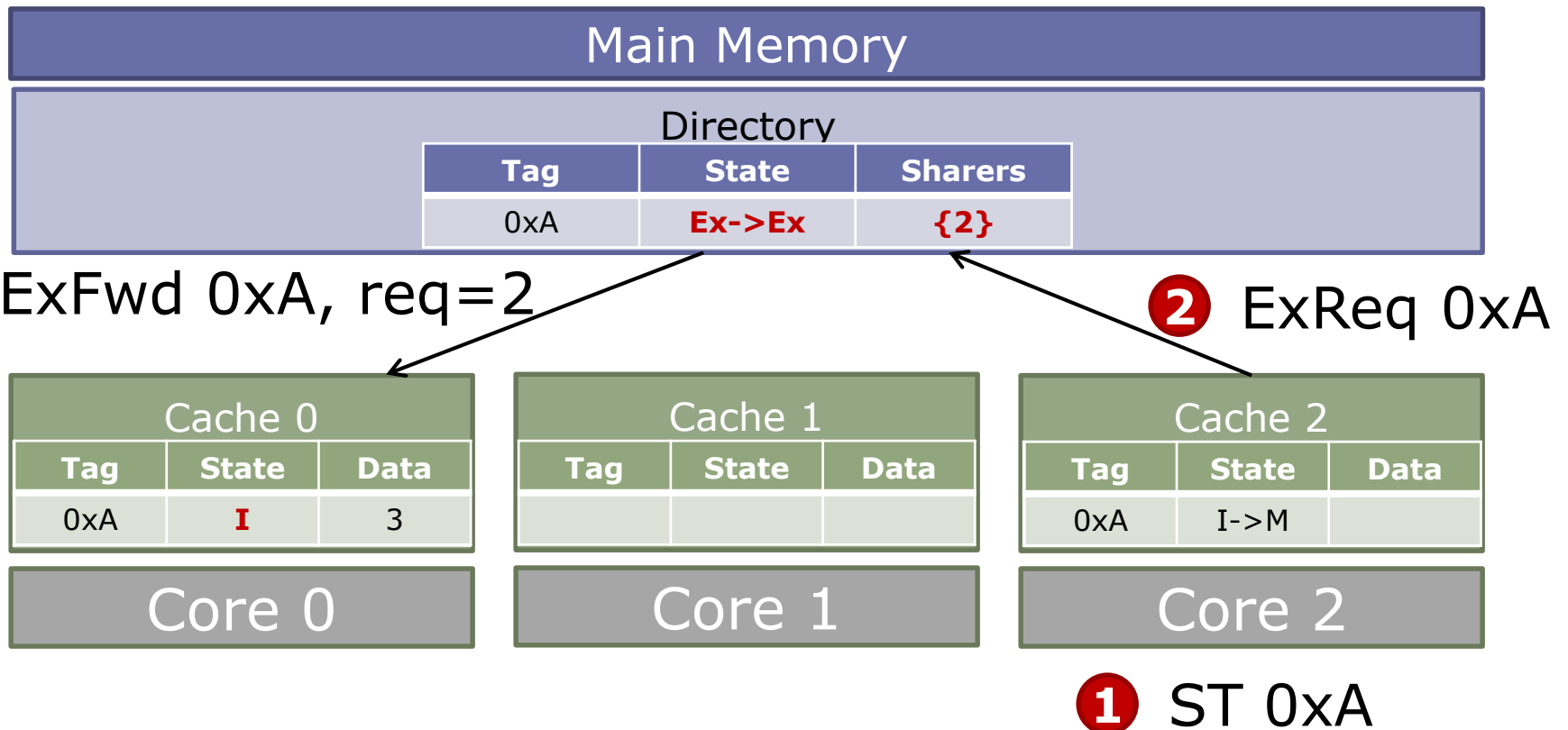

Extra Hops and 3-Hop Protocols

Reducing Protocol Latency

- Problem: Data in another cache needs to pass through the directory, adding latency
- Optimization: Forward data to requester directly

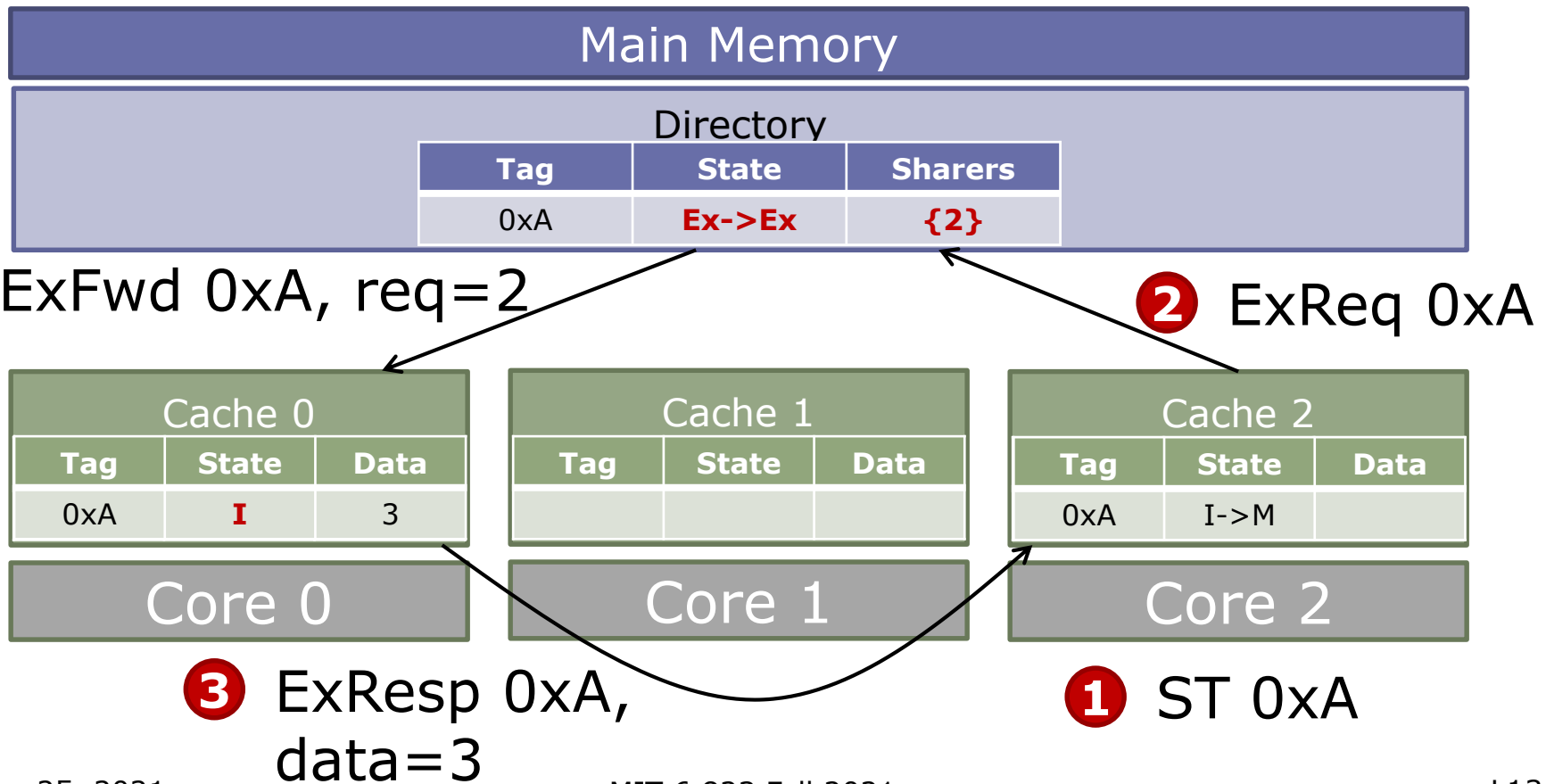

Extra Hops and 3-Hop Protocols

Reducing Protocol Latency

- Problem: Data in another cache needs to pass through the directory, adding latency
- Optimization: Forward data to requester directly

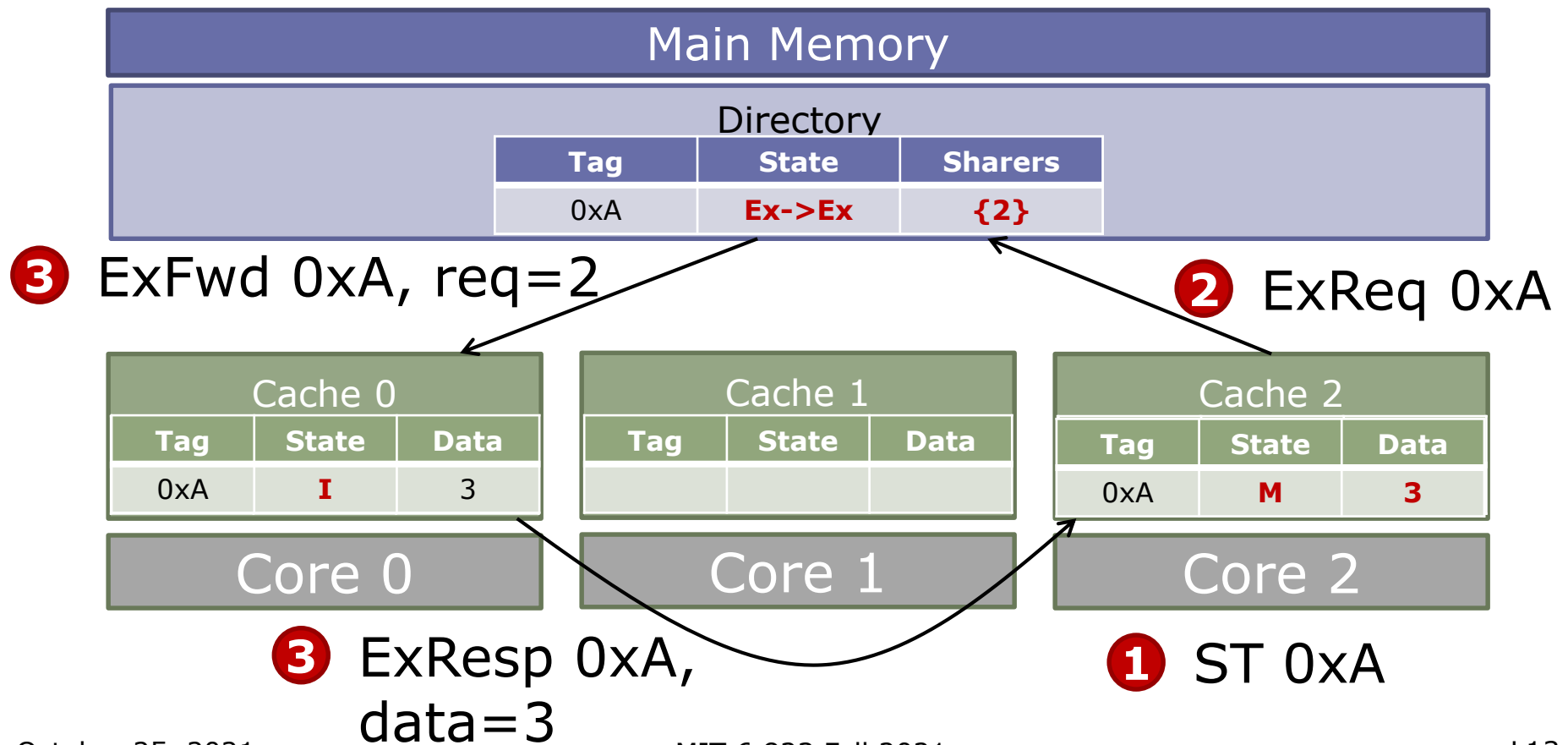

Extra Hops and 3-Hop Protocols

Reducing Protocol Latency

- Problem: Data in another cache needs to pass through the directory, adding latency
- Optimization: Forward data to requester directly

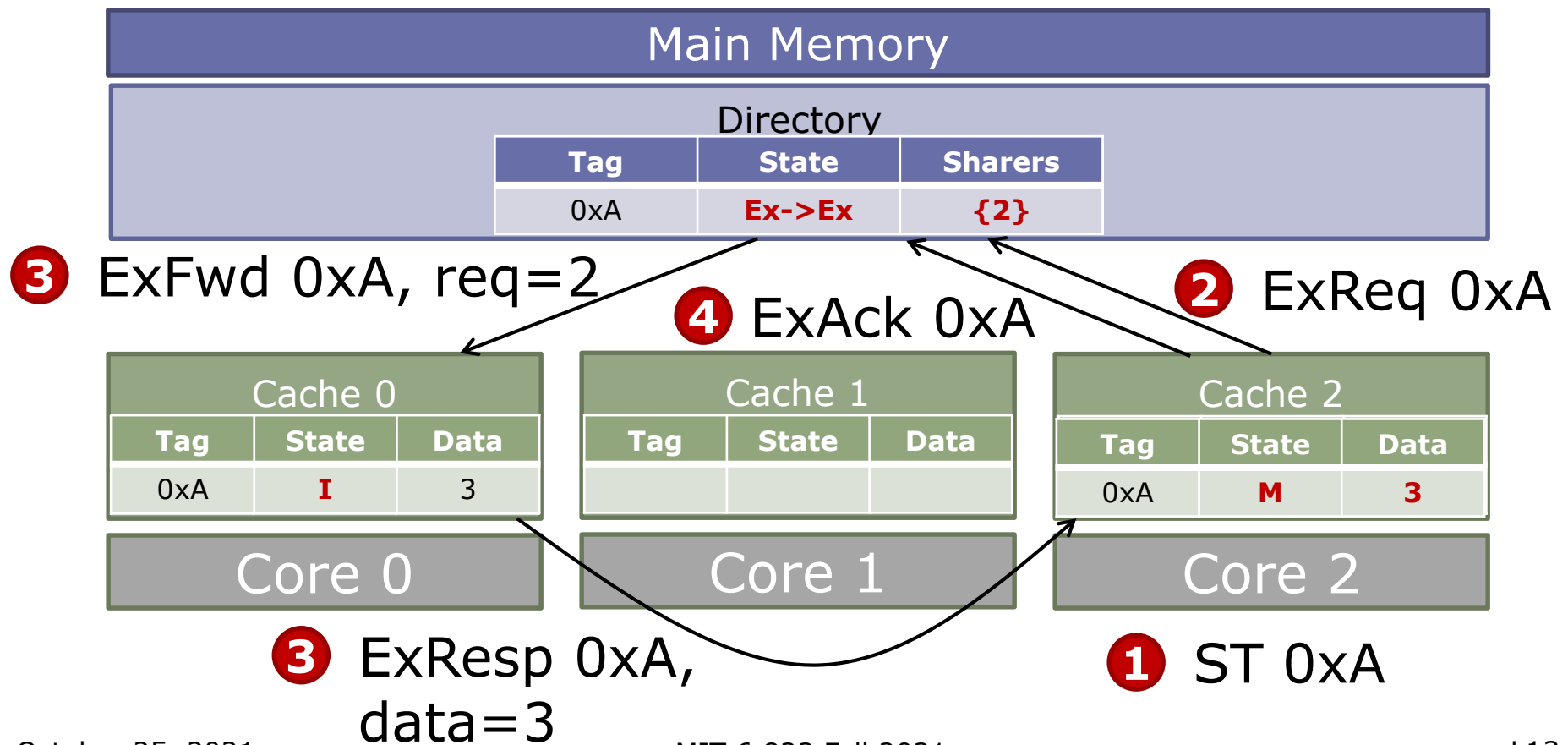

Extra Hops and 3-Hop Protocols

Reducing Protocol Latency

- Problem: Data in another cache needs to pass through the directory, adding latency
- Optimization: Forward data to requester directly

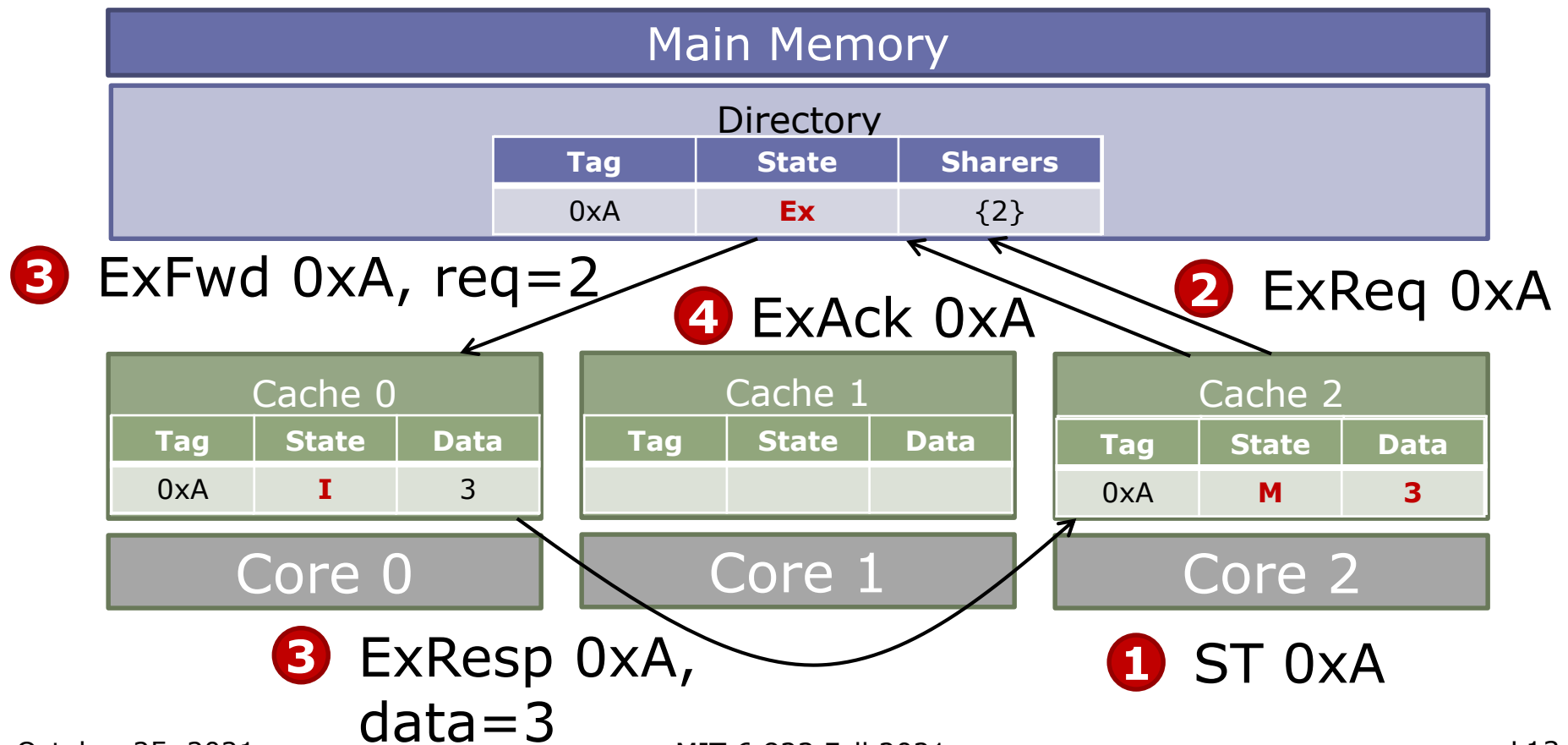

Coherence in Multi-Level Hierarchies

- Can use the same or different protocols to keep coherence across multiple levels
- Key invariant: Ensure sufficient permissions in all intermediate levels
- Example: 8-socket Xeon E7 (8 cores/socket)

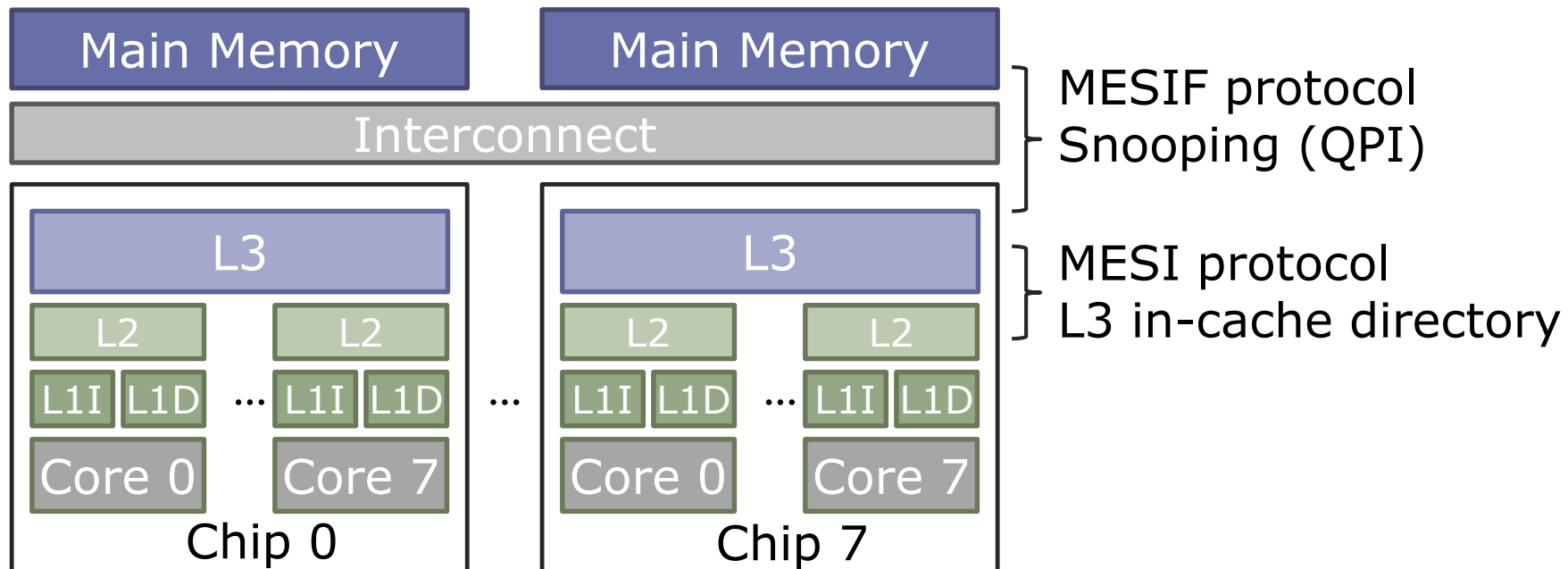

In-Cache Directories

- Common multicore memory hierarchy:
 - 1+ levels of private caches
 - A shared last-level cache
 - Need to enforce coherence among private caches
- Idea: Embed the directory information in shared cache tags
 - Shared cache must be inclusive

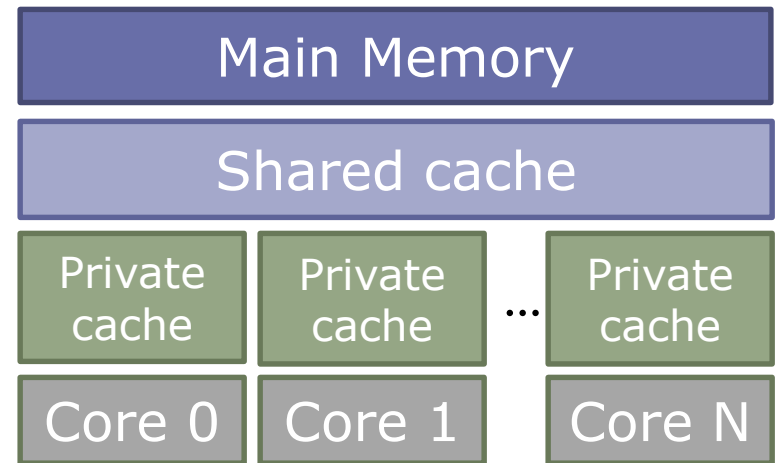

In-Cache Directories

- Common multicore memory hierarchy:
 - 1+ levels of private caches
 - A shared last-level cache
 - Need to enforce coherence among private caches
- Idea: Embed the directory information in shared cache tags
 - Shared cache must be inclusive

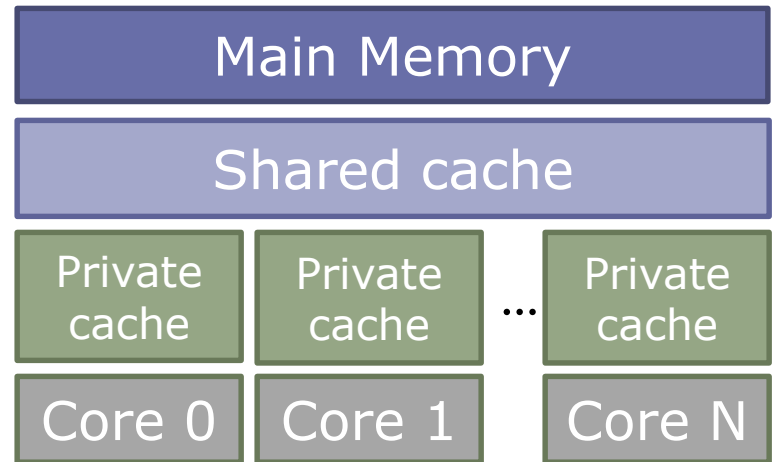

- ✓ Avoids tag overheads & separate lookups
- ✗ Can be inefficient if shared cache size \gg sum(private cache sizes)

Avoiding Protocol Deadlock

- Protocols can cause deadlocks even if network is deadlock-free! (*more on this later*)

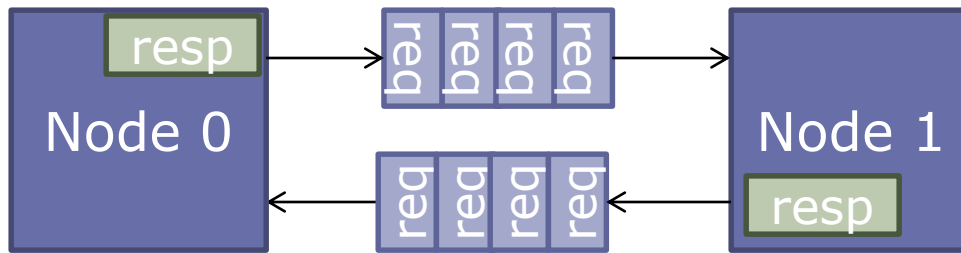

Example: Both nodes saturate all intermediate buffers with requests to each other, blocking responses from entering the network

Avoiding Protocol Deadlock

- Protocols can cause deadlocks even if network is deadlock-free! (*more on this later*)

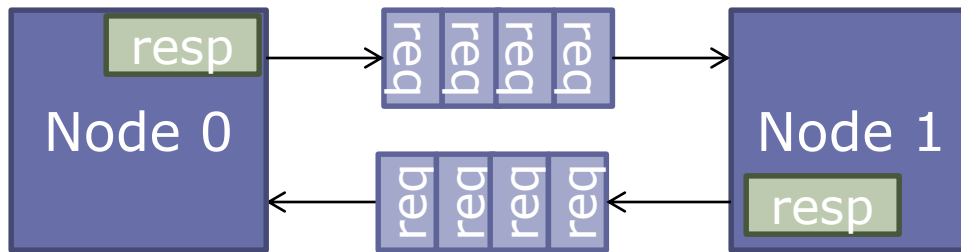

Example: Both nodes saturate all intermediate buffers with requests to each other, blocking responses from entering the network

- Solution: Separate *virtual networks*
 - Different sets of virtual channels and endpoint buffers
 - Same physical routers and links

Avoiding Protocol Deadlock

- Protocols can cause deadlocks even if network is deadlock-free! (*more on this later*)

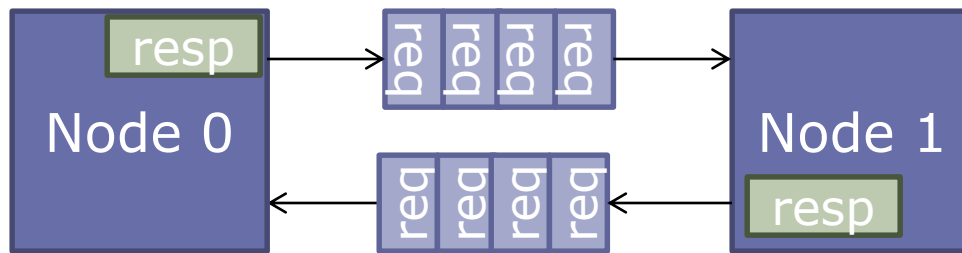

Example: Both nodes saturate all intermediate buffers with requests to each other, blocking responses from entering the network

- Solution: Separate *virtual networks*
 - Different sets of virtual channels and endpoint buffers
 - Same physical routers and links
- Most protocols require at least 2 virtual networks (for requests and replies), often >2 needed

Coherence and Synchronization

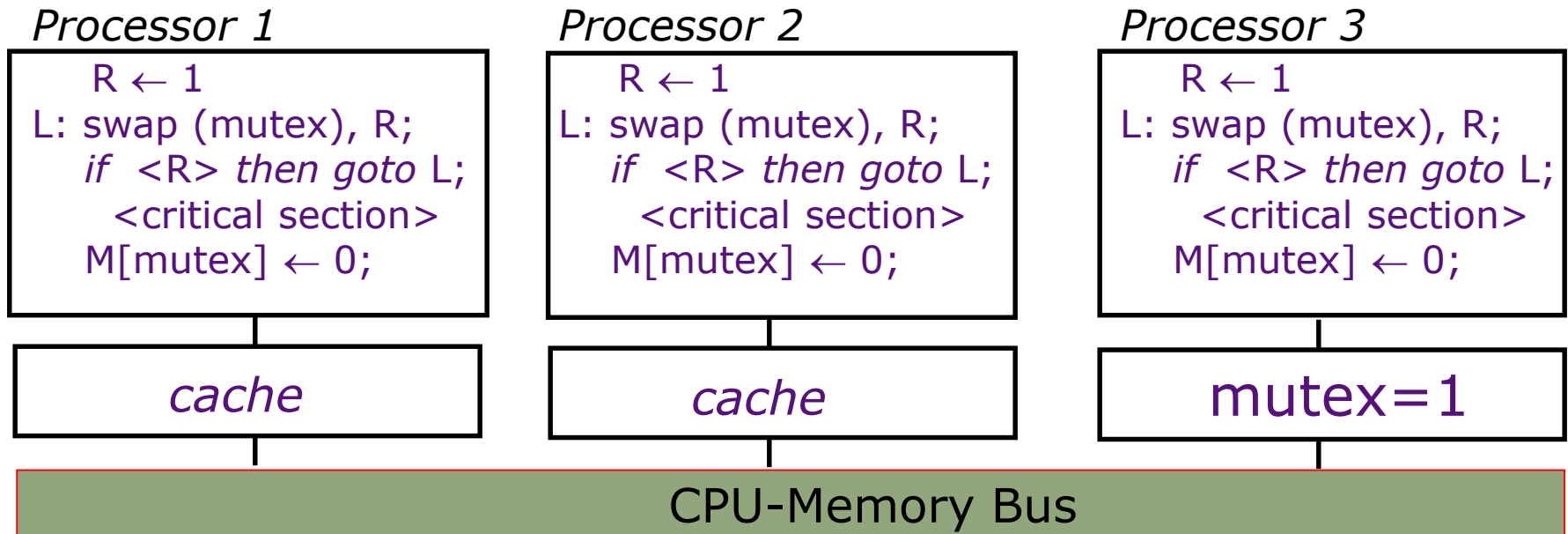

Coherence and Synchronization

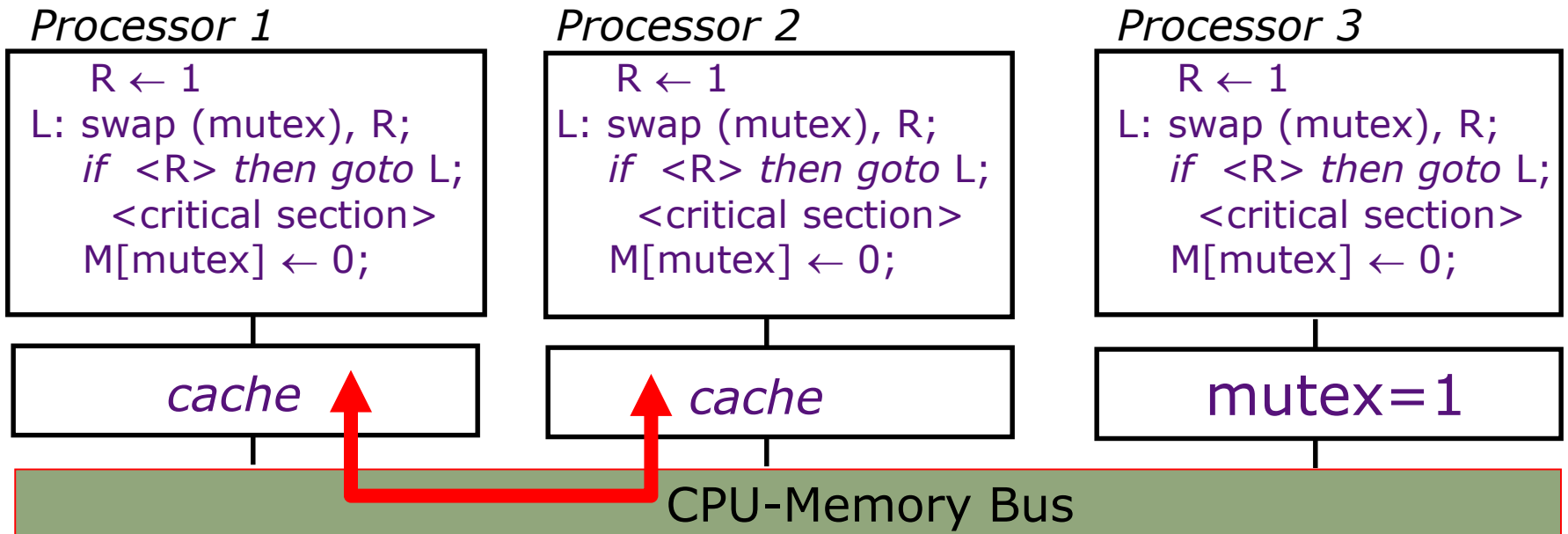

Cache coherence protocols will cause **mutex** to *ping-pong* between P1's and P2's caches.

Coherence and Synchronization

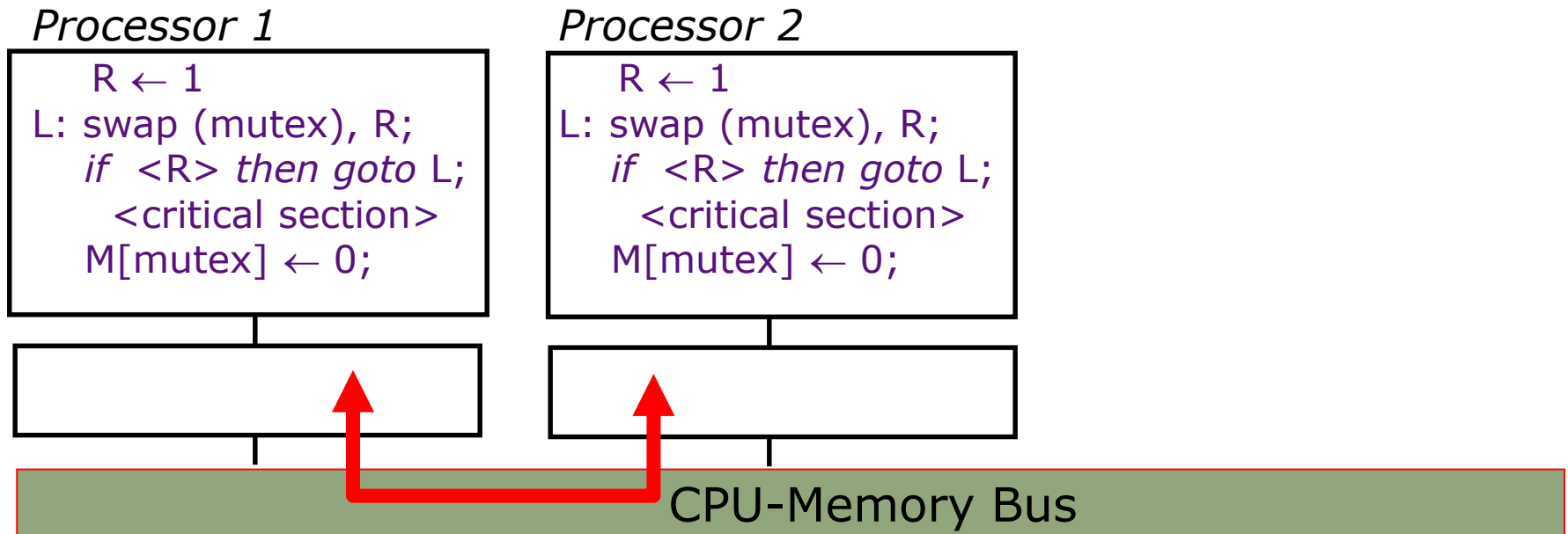

Cache coherence protocols will cause **mutex** to *ping-pong* between P1's and P2's caches.

Coherence and Synchronization

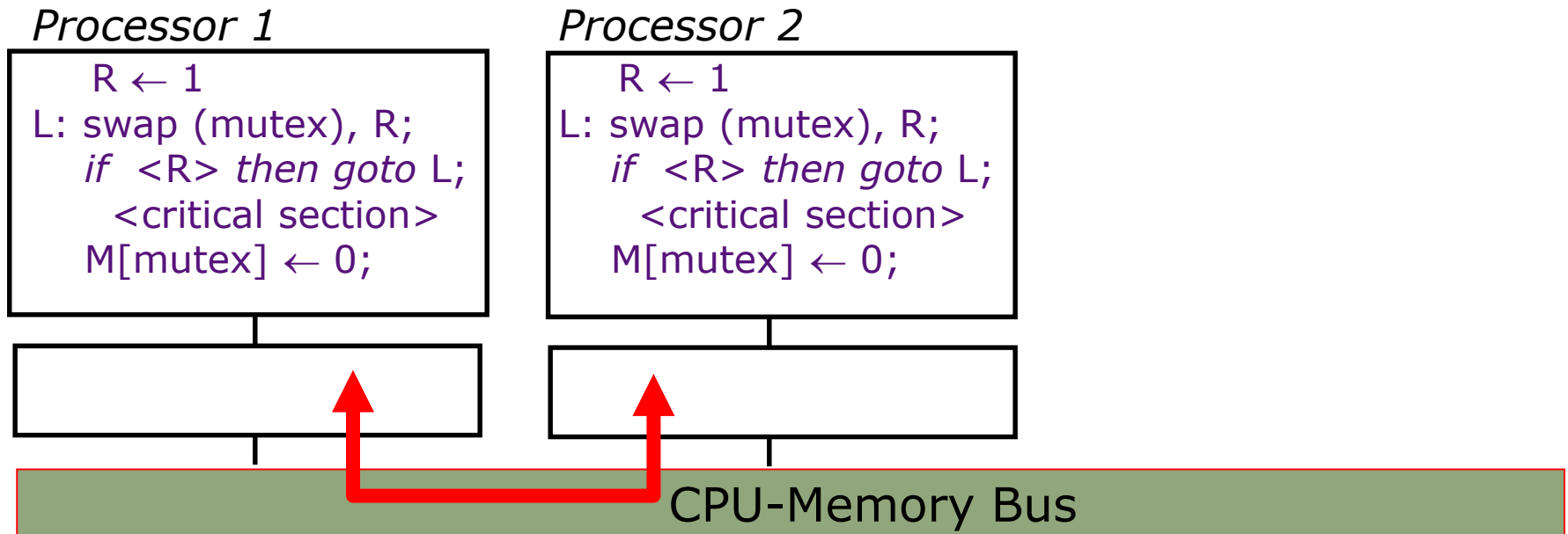

Cache coherence protocols will cause **mutex** to *ping-pong* between P1's and P2's caches.

Ping-ponging can be reduced by first reading the **mutex** location (*non-atomically*) and executing a swap only if it is found to be zero (test&test&set).

Implementing Atomic Instructions

- In general, an *atomic read-modify-write* instruction requires two memory operations without intervening memory operations by other processors

Implementing Atomic Instructions

- In general, an *atomic read-modify-write* instruction requires two memory operations without intervening memory operations by other processors
- Implementation options:
 - *With snoopy coherence, lock the bus → expensive*

Implementing Atomic Instructions

- In general, an *atomic read-modify-write* instruction requires two memory operations without intervening memory operations by other processors
- Implementation options:
 - *With snoopy coherence, lock the bus → expensive*
 - *With directory-based coherence, lock the line in the cache (prevent invalidations or evictions until atomic op finishes) → complex*

Implementing Atomic Instructions

- In general, an *atomic read-modify-write* instruction requires two memory operations without intervening memory operations by other processors
- Implementation options:
 - *With snoopy coherence, lock the bus → expensive*
 - *With directory-based coherence, lock the line in the cache (prevent invalidations or evictions until atomic op finishes) → complex*
- Modern processors often use
load-reserve
store-conditional

Load-reserve & Store-conditional

Special register(s) to hold reservation flag and address, and the outcome of store-conditional

```
Load-reserve R, (a):  
  <flag, adr> ← <1, a>;  
  R ← M[a];
```

```
Store-conditional (a), R:  
  if <flag, adr> == <1, a>  
  then cancel other procs'  
        reservation on a;  
        M[a] ← <R>;  
        status ← succeed;  
  else status ← fail;
```

If the cache receives an invalidation to the address in the reserve register, the reserve bit is set to **0**

- Several processors may reserve 'a' simultaneously
- These instructions are like ordinary loads and stores with respect to the bus traffic

Load-Reserve/Store-Conditional

Swap implemented with Ld-Reserve/St-Conditional

```
#      Swap(R1, mutex):  
  
L:    Ld-Reserve R2, (mutex)  
      St-Conditional (mutex), R1  
      if (status == fail) goto L  
      R1 <- R2
```

Performance:

Load-reserve & Store-conditional

The total number of coherence transactions is not necessarily reduced, but splitting an atomic instruction into load-reserve & store-conditional:

- *increases utilization* (and reduces processor stall time), especially in split-transaction buses and directories
- *reduces cache ping-pong effect* because processors trying to acquire a semaphore do not have to perform stores each time

Thank you!

*Next Lecture:
Consistency and
Relaxed Memory Models*