

Instruction Pipelining

Ryan Lee

Computer Science and Artificial Intelligence Laboratory
M.I.T.

Announcements

- Lab 1 released later today
 - Designing 3 different cache models using Pin
 - Due Oct. 1
- Please view the Pin tutorial video posted on the course website (under Recitation tab)
- Contact me if you cannot get access to lab machines

Reminder: Harvard-Style Single-Cycle Datapath for MIPS

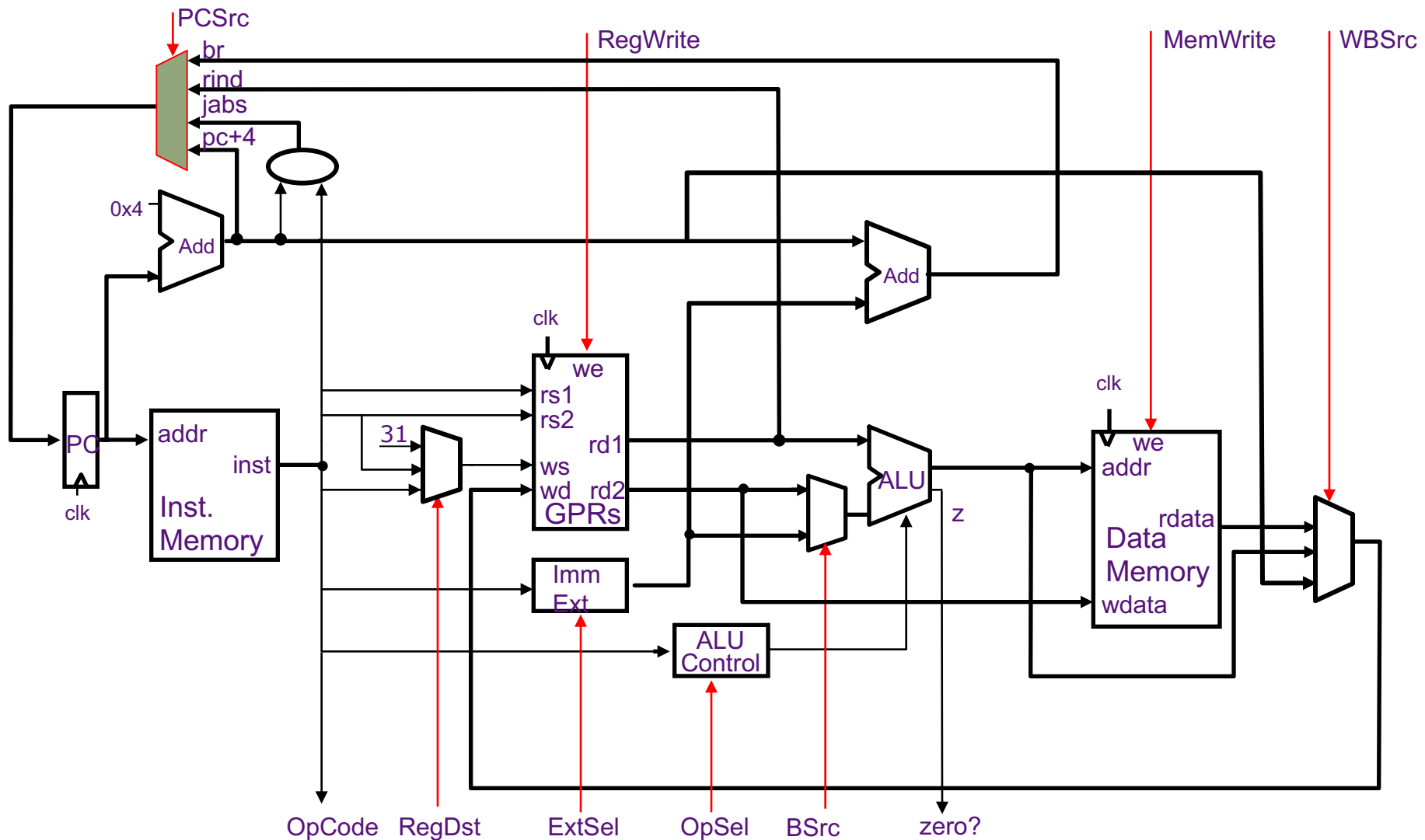

Reminder: Princeton Microarchitecture

Datapath & Control for 2 cycles-per-instruction

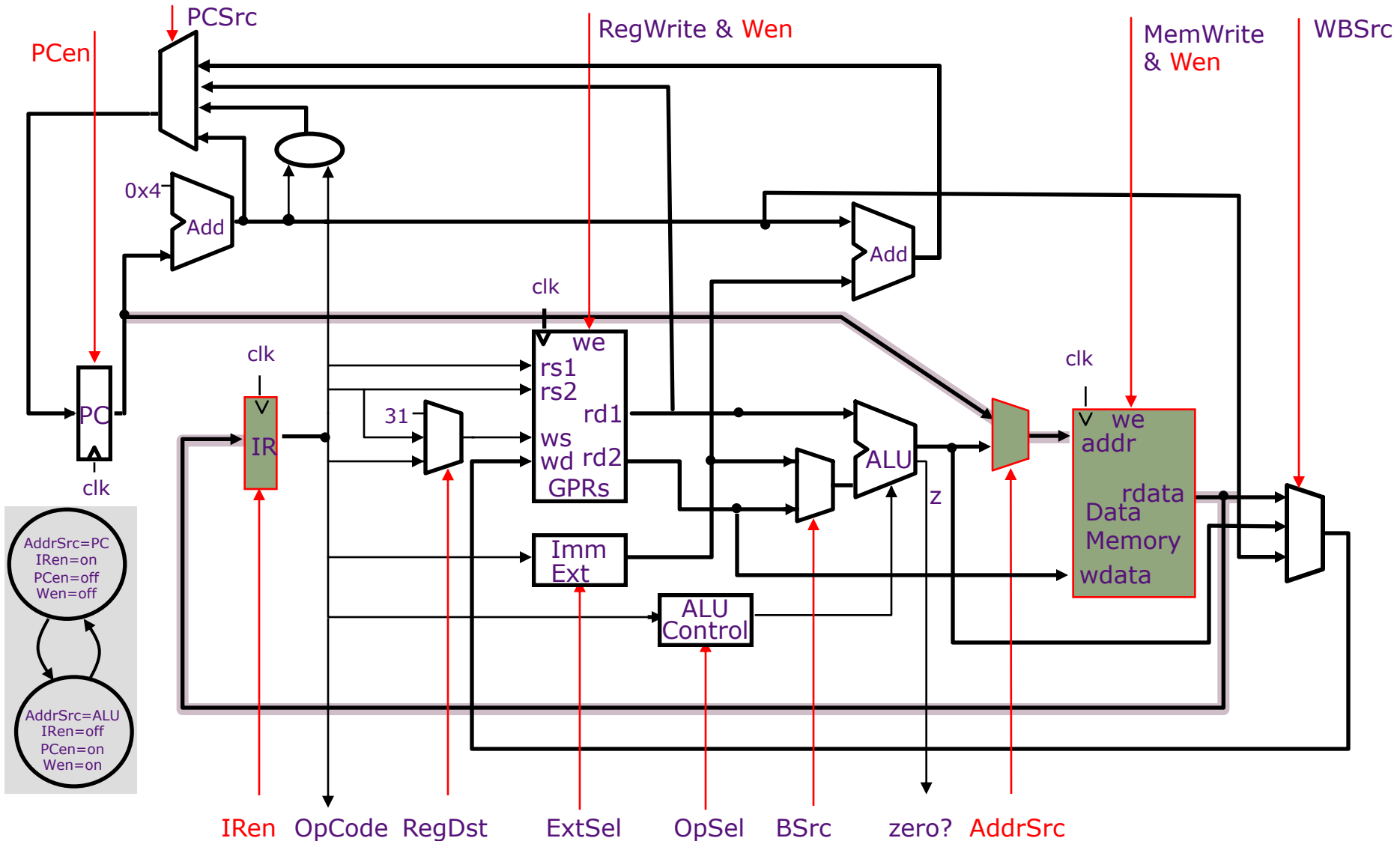

Princeton Microarchitecture (redrawn)

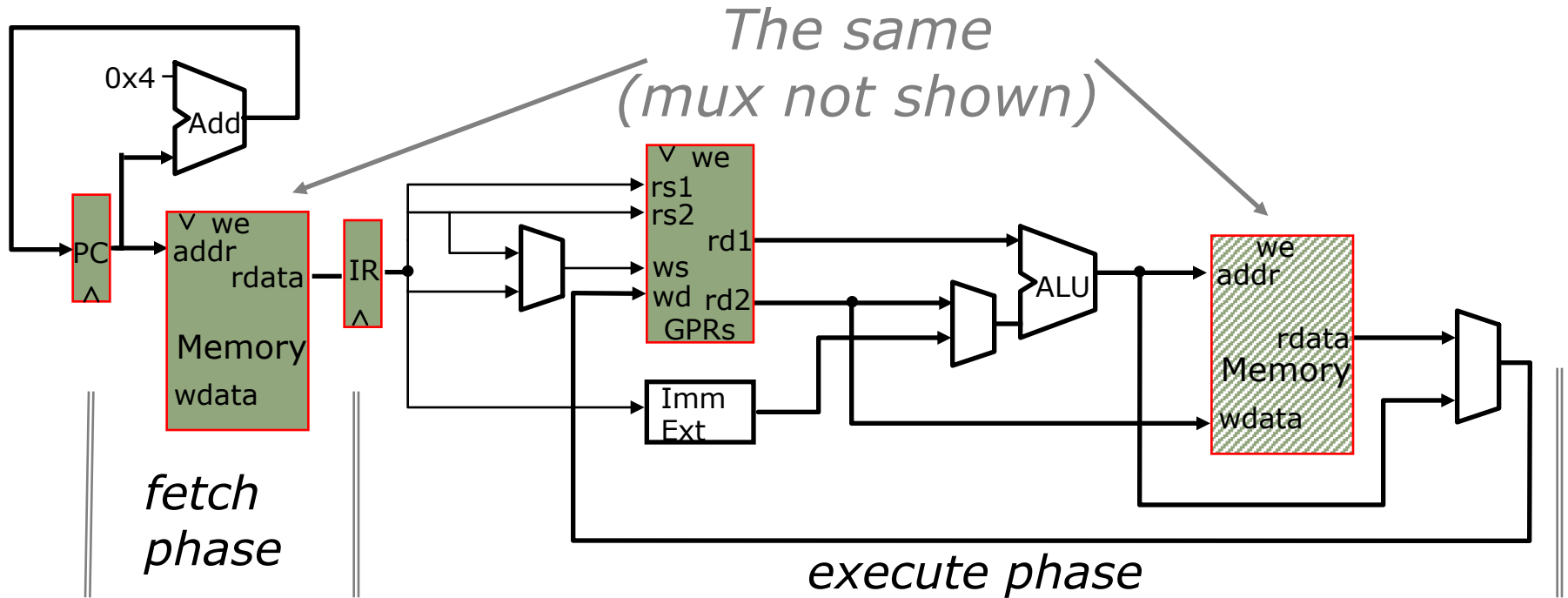

Only one of the phases is active in any cycle
⇒ a lot of datapath not used at any given time

Princeton Microarchitecture

Overlapped execution

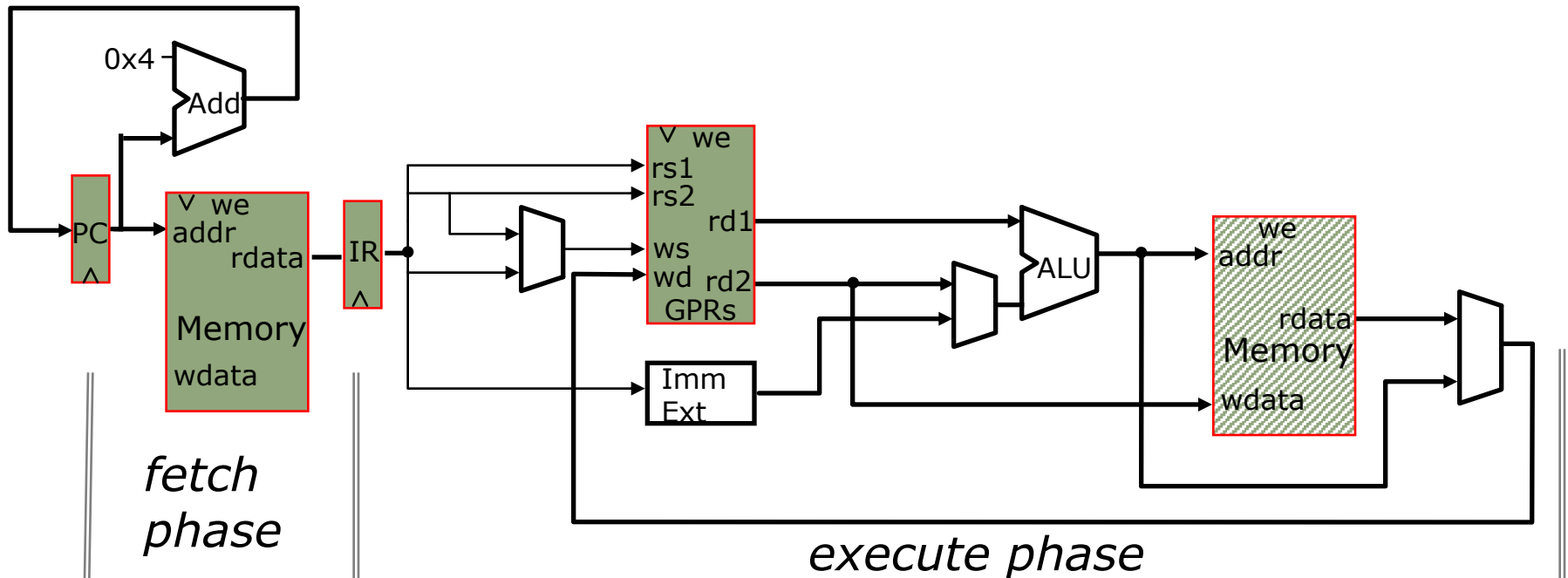

Can we overlap instruction fetch and execute?

Which action should be prioritized?

What do we do with Fetch?

Stalling the instruction fetch

Princeton Microarchitecture

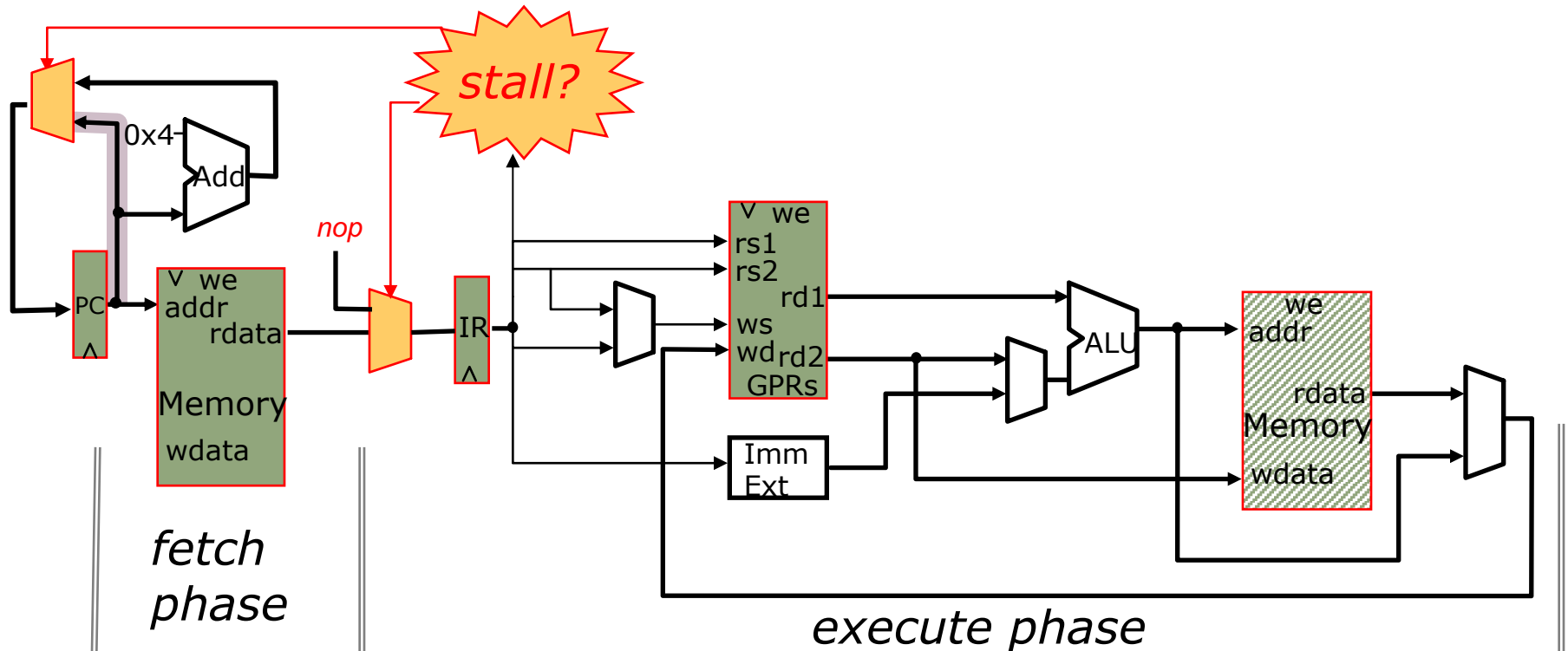

When stall condition is indicated

- *don't fetch a new instruction and don't change the PC*
- *insert a nop in the IR*
- *set the Memory Address mux to ALU (not shown)*

What if IR contains a jump or branch instruction?

Need to stall on branches

Princeton Microarchitecture

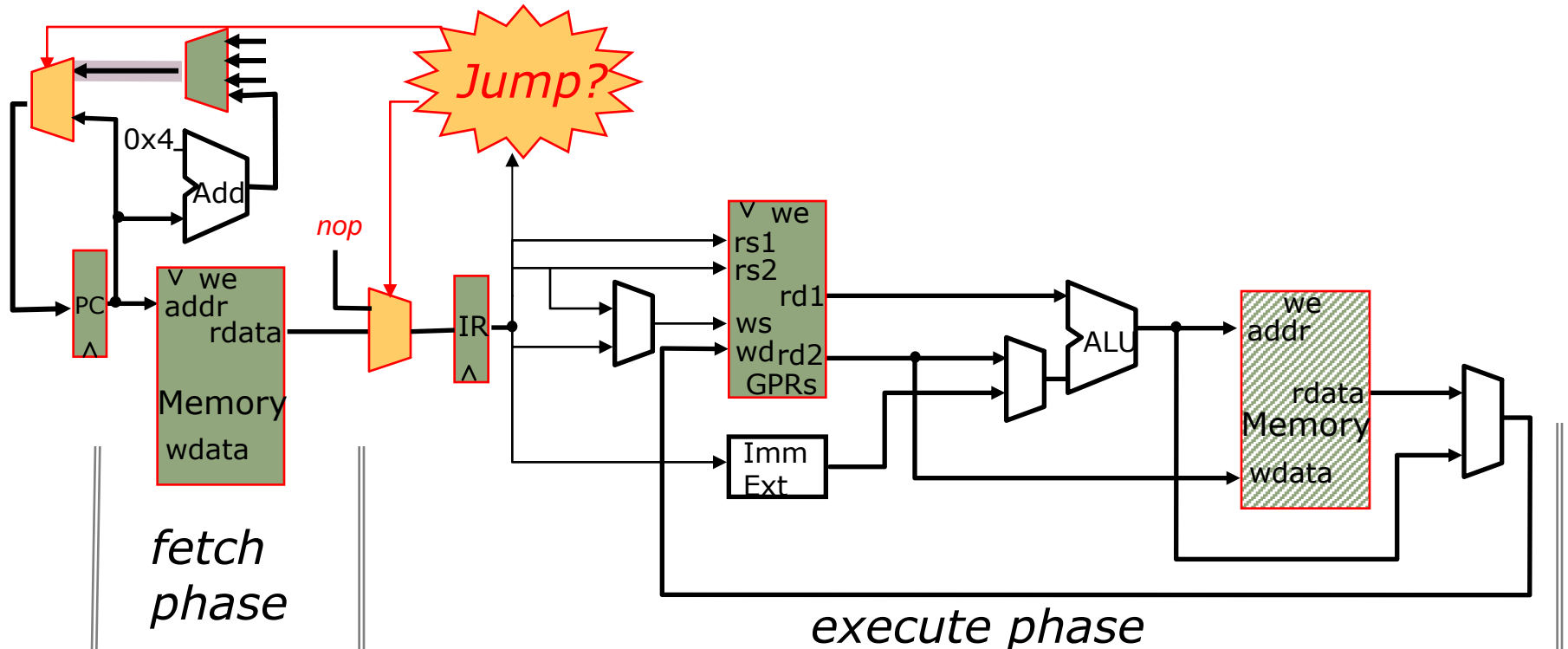

When IR contains a jump or taken branch

- *no "structural conflict" for the memory*
- *but we do not have the correct PC value in the PC*
- *memory cannot be used – Address Mux setting is irrelevant*
- *insert a nop in the IR*
- *insert the nextPC (branch-target) address in the PC*

Pipelined Princeton Microarchitecture

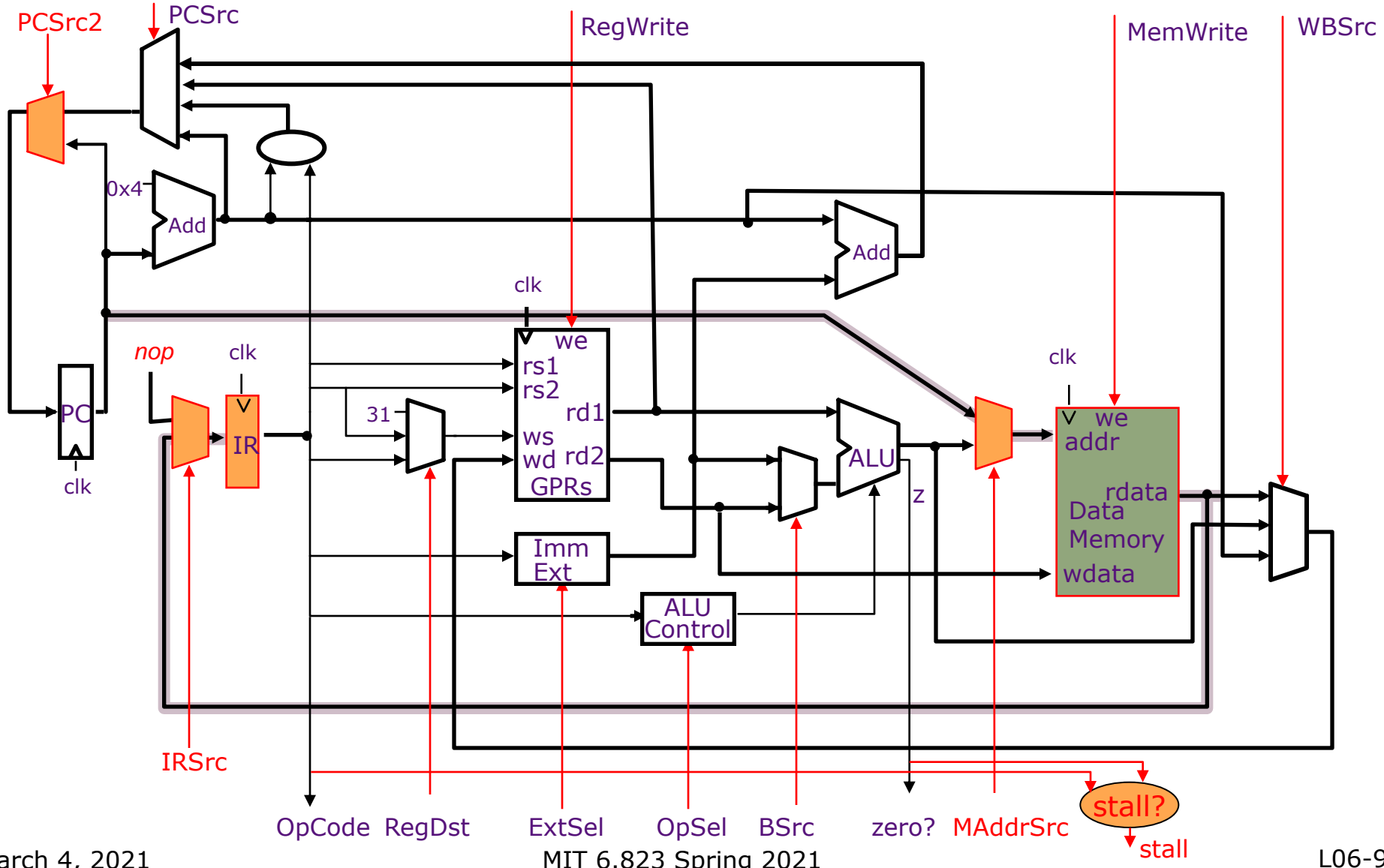

Pipelined Princeton: Control Table

Opcode	Stall	Ext Sel	B Src	Op Sel	Mem W	Reg W	WB Src	Reg Dst	PC Src1	PC Src2	IR Src	MAddr Src
ALU	no	*	Reg	Func	no	yes	ALU	rd	pc+4	npc	mem	pc
ALUi	no	sE ₁₆	Imm	Op	no	yes	ALU	rt	pc+4	npc	mem	pc
ALUiu	no	uE ₁₆	Imm	Op	no	yes	ALU	rt	pc+4	npc	mem	pc
LW	yes	sE ₁₆	Imm	+	no	yes	Mem	rt	pc+4	pc	nop	ALU
SW	yes	sE ₁₆	Imm	+	yes	no	*	*	pc+4	pc	nop	ALU
BEQZ _{Z=1}	yes	sE ₁₆	*	0?	no	no	*	*	br	npc	nop	*
BEQZ _{Z=0}	no	sE ₁₆	*	0?	no	no	*	*	pc+4	npc	mem	pc
J	yes	*	*	*	no	no	*	*	jabs	npc	nop	*
JAL	yes	*	*	*	no	yes	PC	R31	jabs	npc	nop	*
JR	yes	*	*	*	no	no	*	*	rind	npc	nop	*
JALR	yes	*	*	*	no	yes	PC	R31	rind	npc	nop	*
NOP	no	*	*	*	no	no	*	*	pc+4	npc	mem	pc

BSrc = Reg / Imm ; WBSrc = ALU / Mem / PC; IRSrc = nop/mem; MAddrSrc = pc/ALU
 RegDst = rt / rd / R31; PCSrc1 = pc+4 / br / rind / jabs; PCSrc2 = pc/nPC

stall & IRSrc columns are identical

Pipelined Princeton Architecture

Clock: $t_{\text{C-Princeton}} > t_{\text{RF}} + t_{\text{ALU}} + t_{\text{M}} + t_{\text{WB}}$

CPI: $(1 - f) + 2f$ cycles per instruction
where f is the fraction of
instructions that cause a stall

What is a likely value of f ?

An Ideal Pipeline

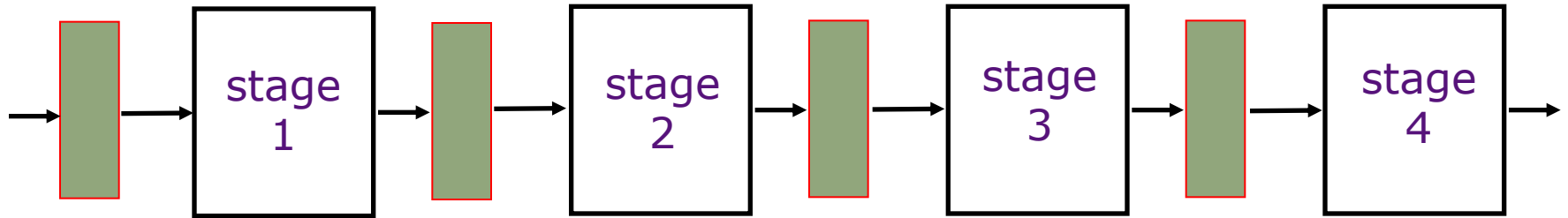

- All objects go through the same stages
- No sharing of resources between any two stages
- Propagation delay through all pipeline stages is equal
- The scheduling of an object entering the pipeline is not affected by the objects in other stages

These conditions generally hold for industrial assembly lines.

But what about an instruction pipeline?

Pipelined Datapath

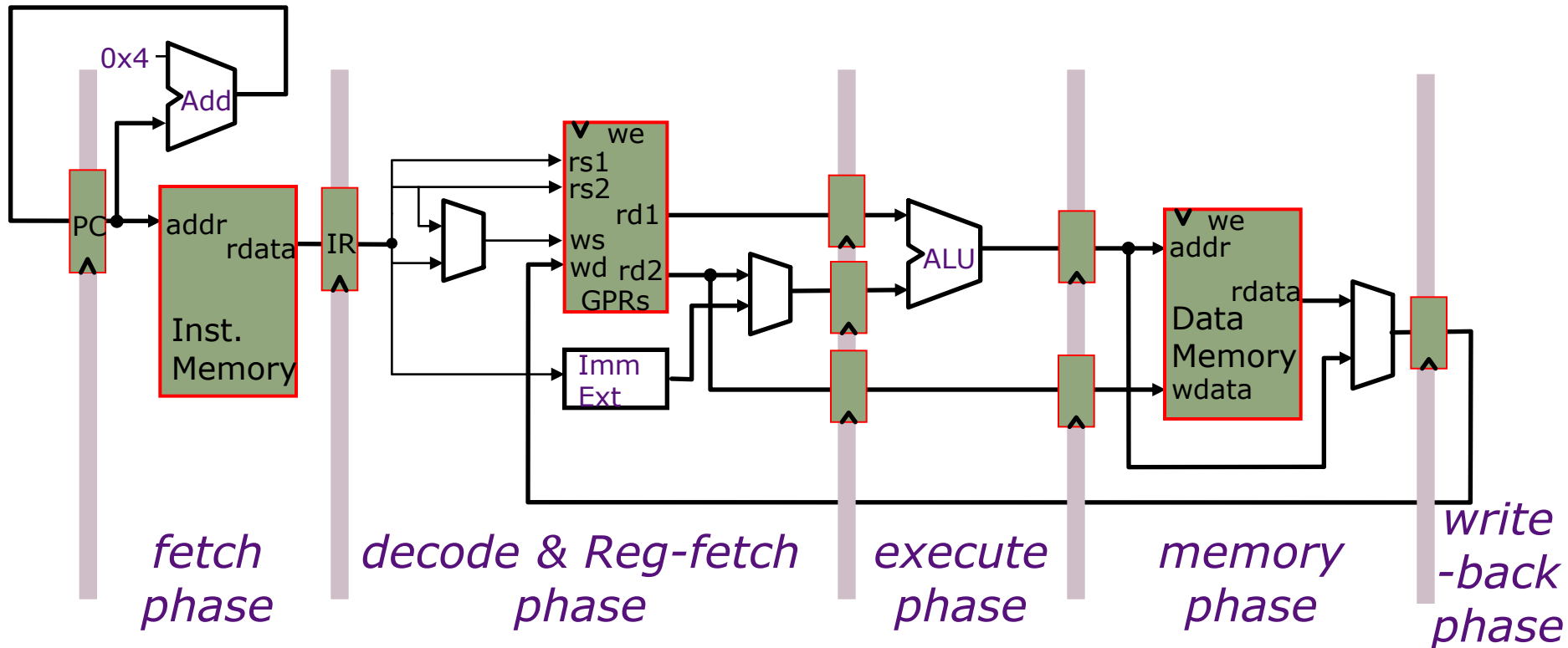

Clock period can be reduced by dividing the execution of an instruction into multiple cycles

$$t_c > \max \{t_{IM}, t_{RF}, t_{ALU}, t_{DM}, t_{RW}\} \quad (= t_{DM} \text{ probably})$$

However, CPI will increase unless instructions are pipelined

How to divide datapath into stages

Suppose memory is significantly slower than other stages. For example, suppose

$$\begin{aligned}t_{IM} &= 10 \text{ units} \\t_{DM} &= 10 \text{ units} \\t_{ALU} &= 5 \text{ units} \\t_{RF} &= 1 \text{ unit} \\t_{RW} &= 1 \text{ unit}\end{aligned}$$

Since the slowest stage determines the clock, it may be possible to combine some stages without any loss of performance

Alternative Pipelining

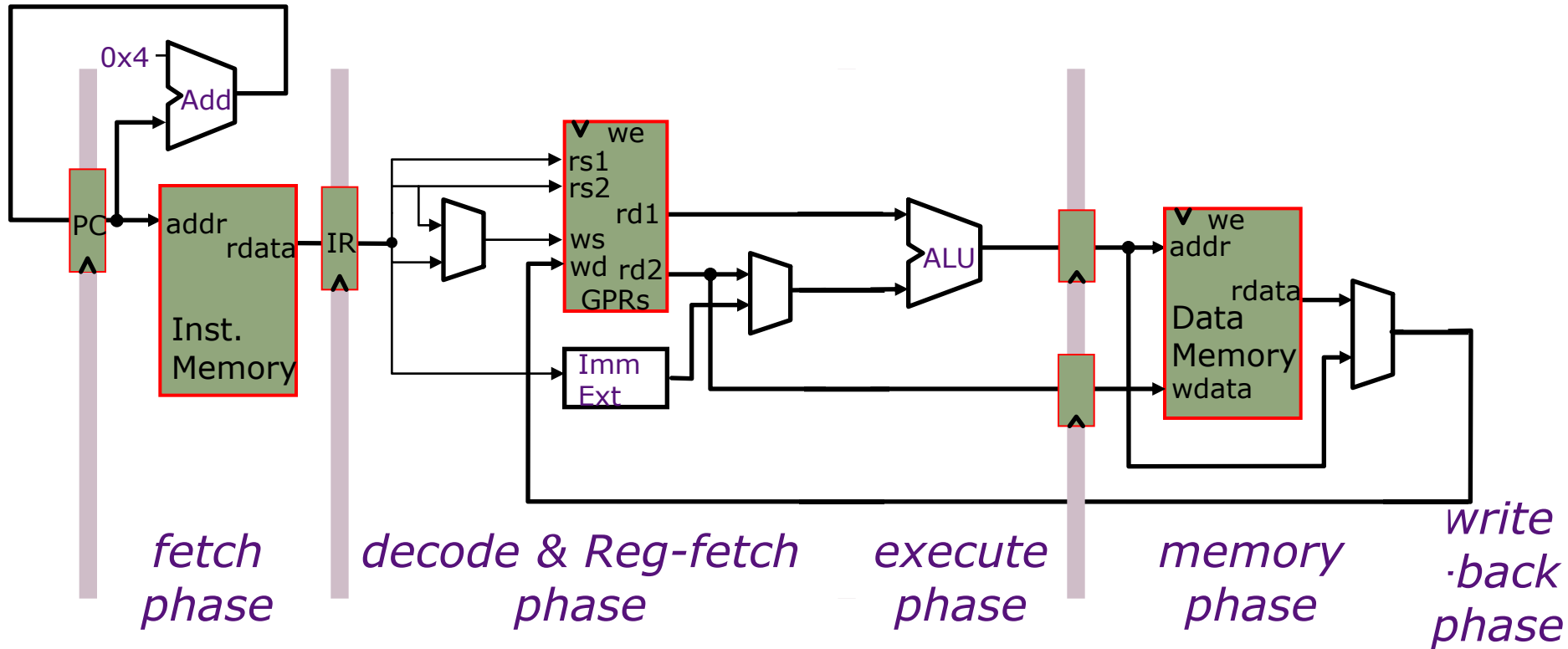

$$t_C > \max \{t_{IM}, t_{RF}+t_{ALU}, t_{DM}+t_{RW}\} = t_{DM} + t_{RW}$$

Write-back stage takes much less time than other stages.
Suppose we combined it with the memory phase

Maximum Speedup by Pipelining

Assumptions	Unpipelined t_c	Pipelined Speedup t_c
1. $t_{IM} = t_{DM} = 10,$ $t_{ALU} = 5,$ $t_{RF} = t_{RW} = 1$ 4-stage pipeline		
2. $t_{IM} = t_{DM} = t_{ALU} = t_{RF} = t_{RW} = 5$ 4-stage pipeline		
3. $t_{IM} = t_{DM} = t_{ALU} = t_{RF} = t_{RW} = 5$ 5-stage pipeline		

What seems to be the message here?

5-Stage Pipelined Execution

Instruction Flow Diagram

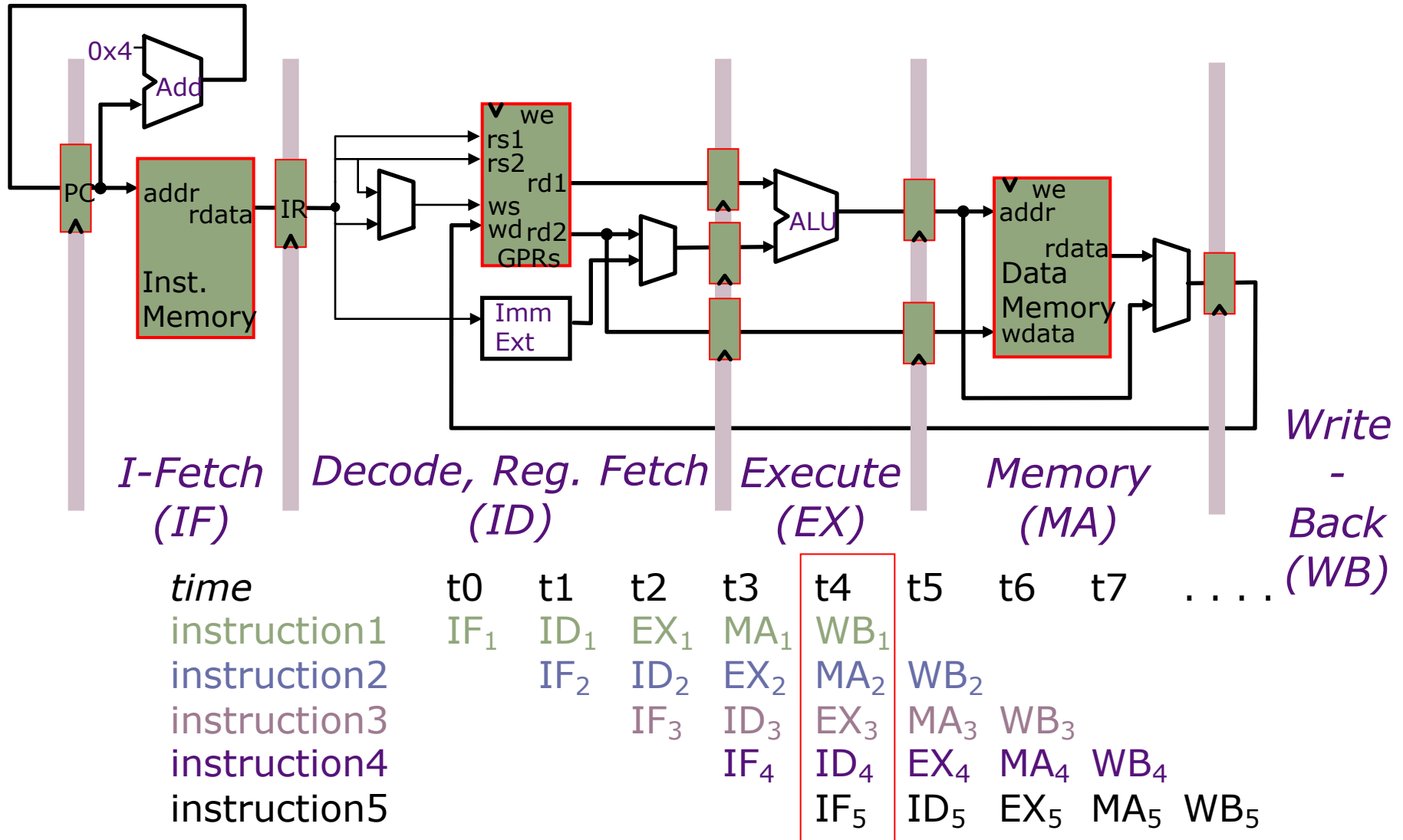

5-Stage Pipelined Execution

Resource Usage Diagram

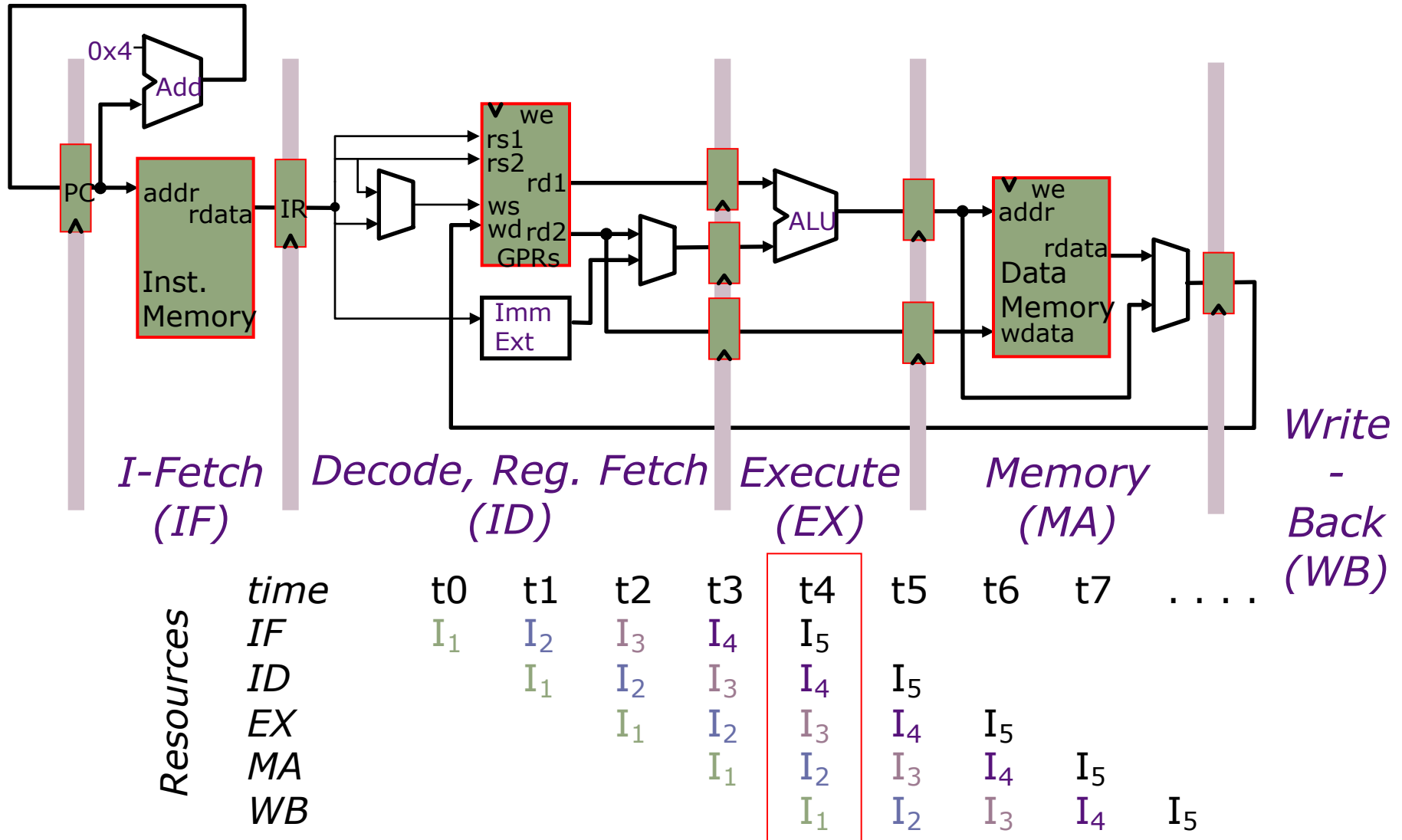

Pipelined Execution

ALU Instructions

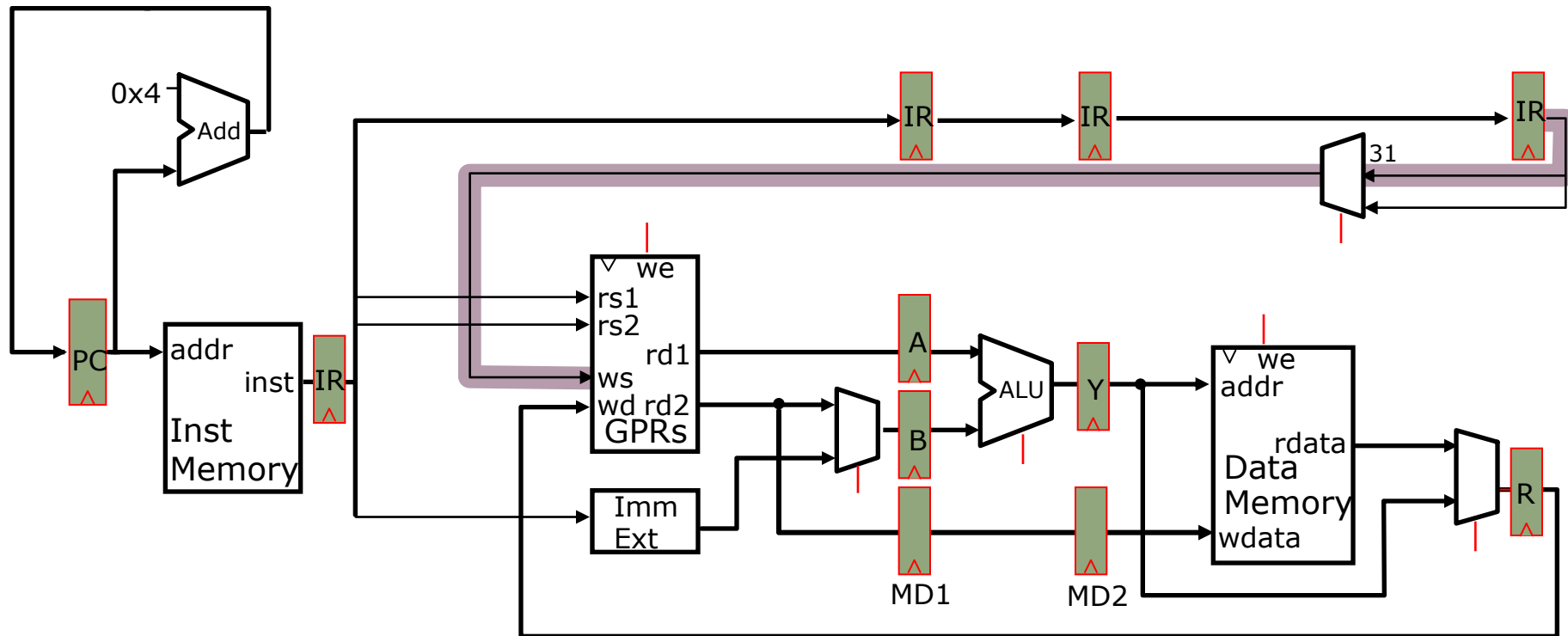

Not quite correct!

Pipelined MIPS Datapath

without jumps

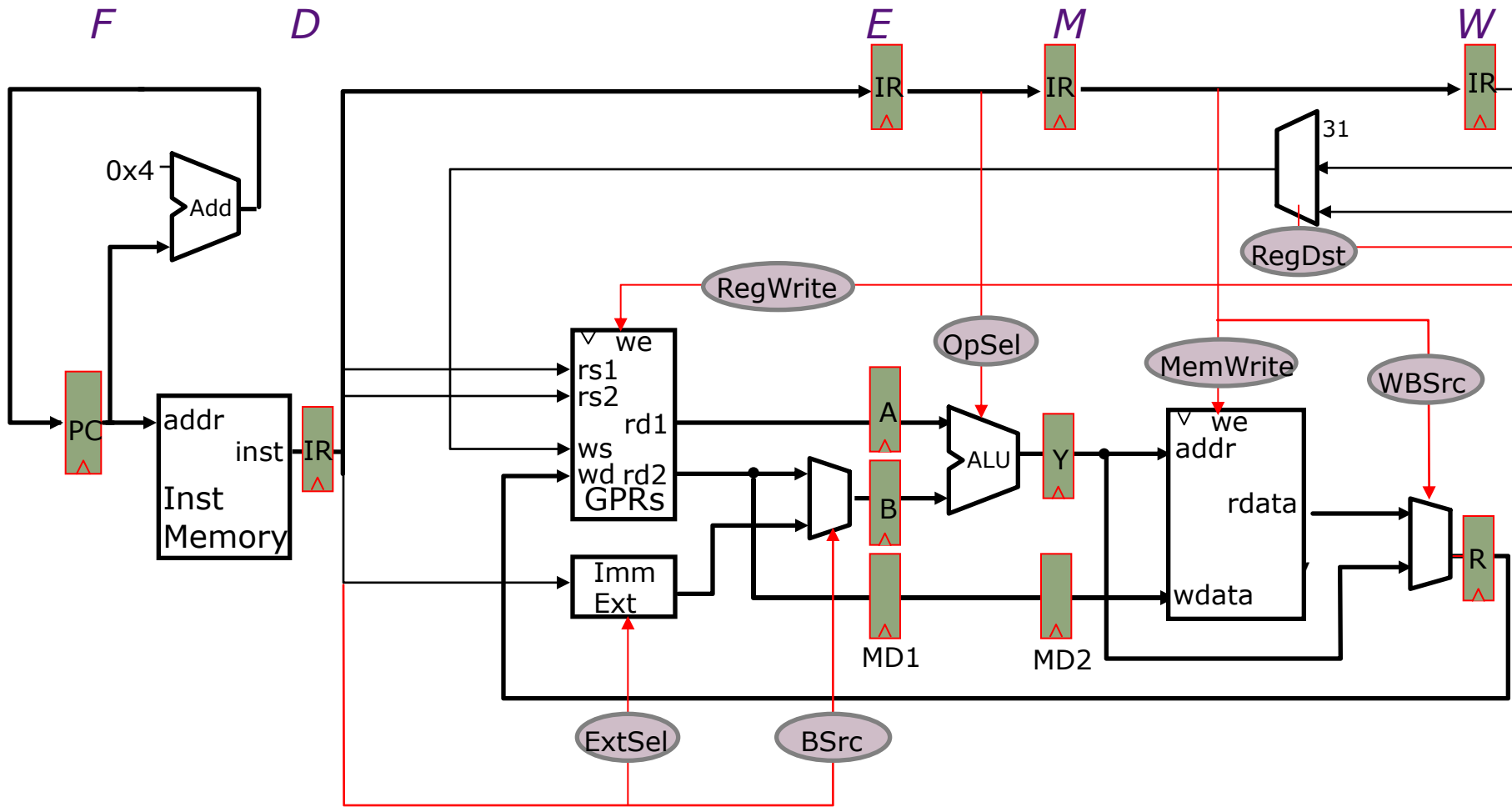

What else is needed?

How instructions can interact with each other in a pipeline

- An instruction in the pipeline may need a resource being used by another instruction in the pipeline
→ *structural hazard*
- An instruction may depend on a value produced by an earlier instruction
 - Dependence may be for a data calculation
→ *data hazard*
 - Dependence may be for calculating the next PC
→ *control hazard (branches, interrupts)*

Resolving Data Hazards

Use strategy from Princeton Pipeline:

*Wait for the result to be available by freezing earlier pipeline stages → **stall***

Feedback to Resolve Hazards

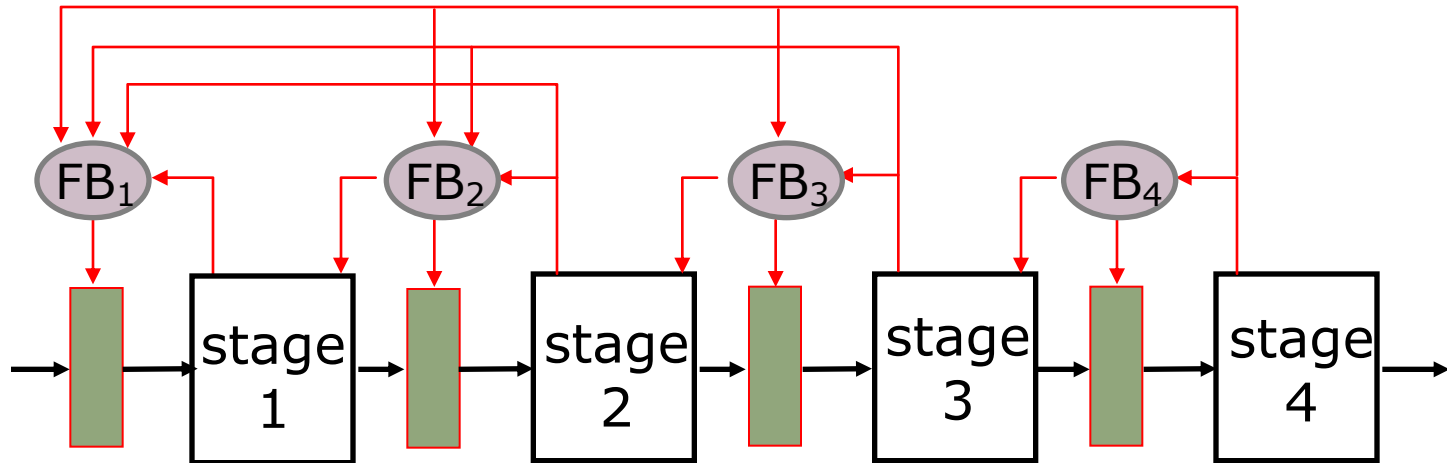

- Later stages provide dependence information to earlier stages which can *stall instructions*
- Controlling a pipeline in this manner works provided *the instruction at stage $i+1$ can complete without any interference from instructions in stages 1 to i* (otherwise deadlocks may occur)

Stalled Stages and Pipeline Bubbles

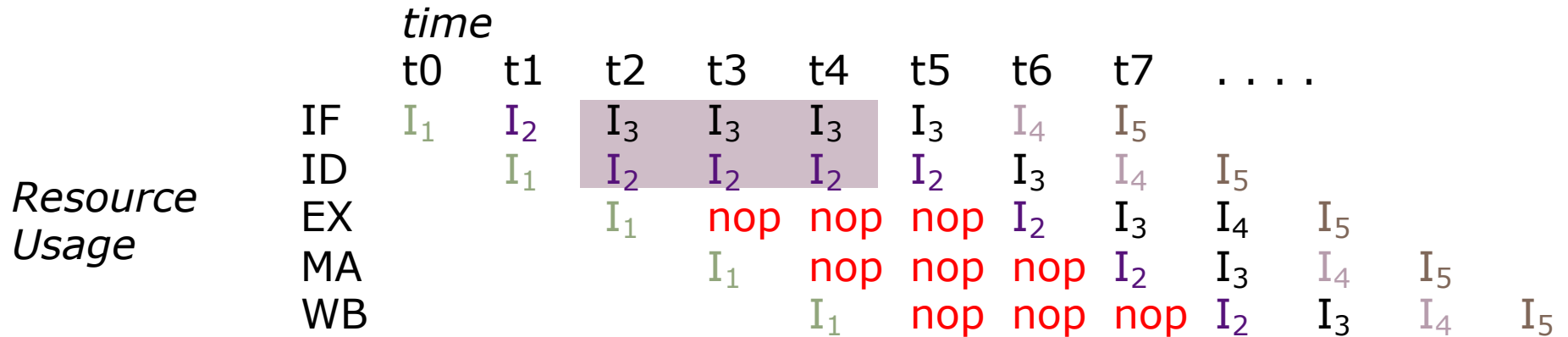
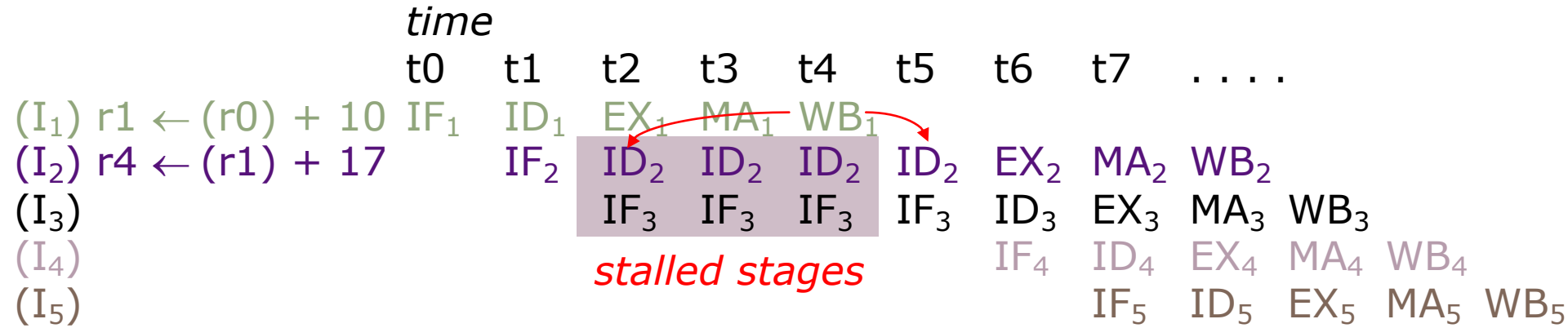

nop ⇒ *pipeline bubble*

Stall Control Logic

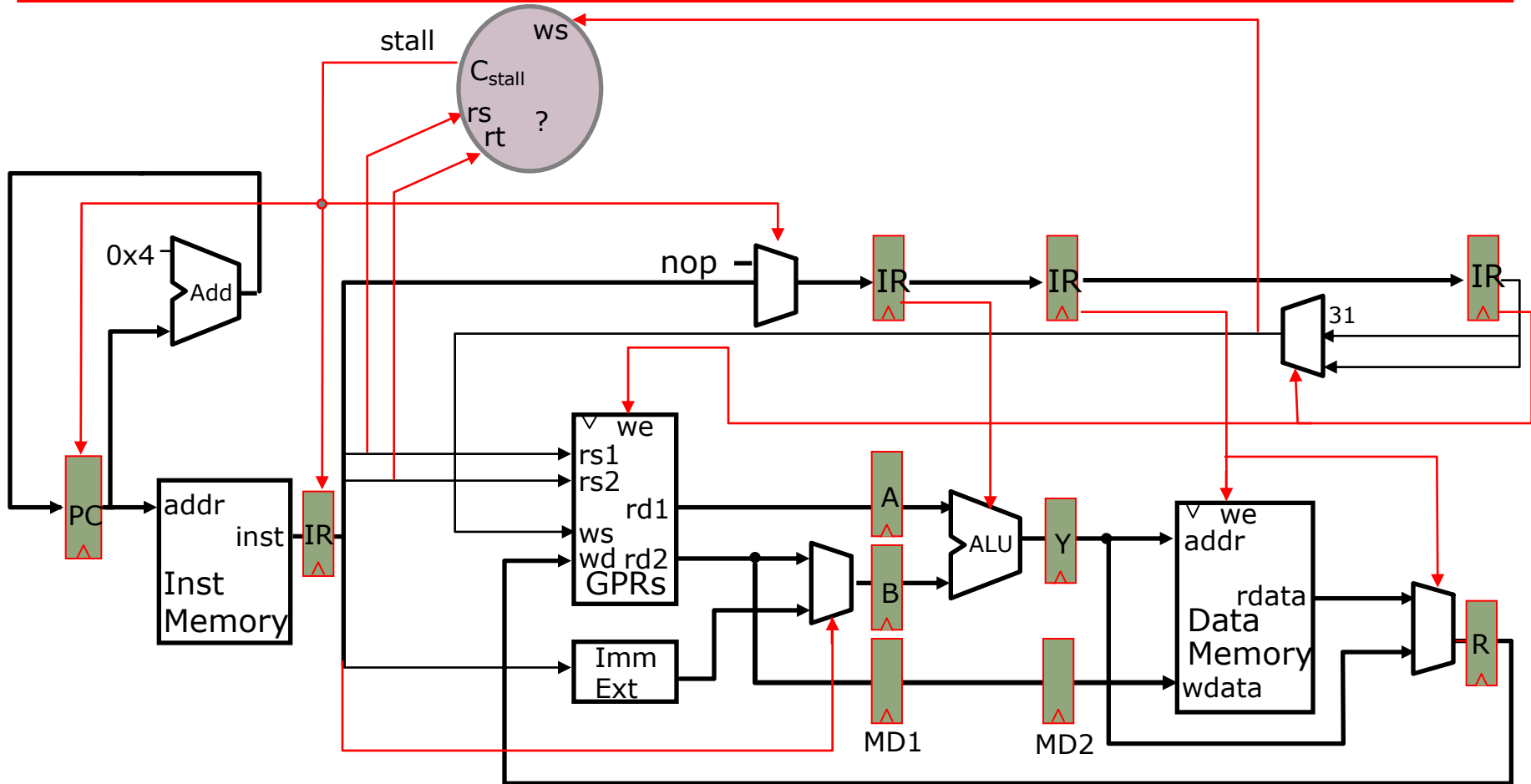

Compare the *source registers* of the instruction in the decode stage with the *destination register* of the *uncommitted instructions*.

Stall Control Logic

ignoring jumps & branches

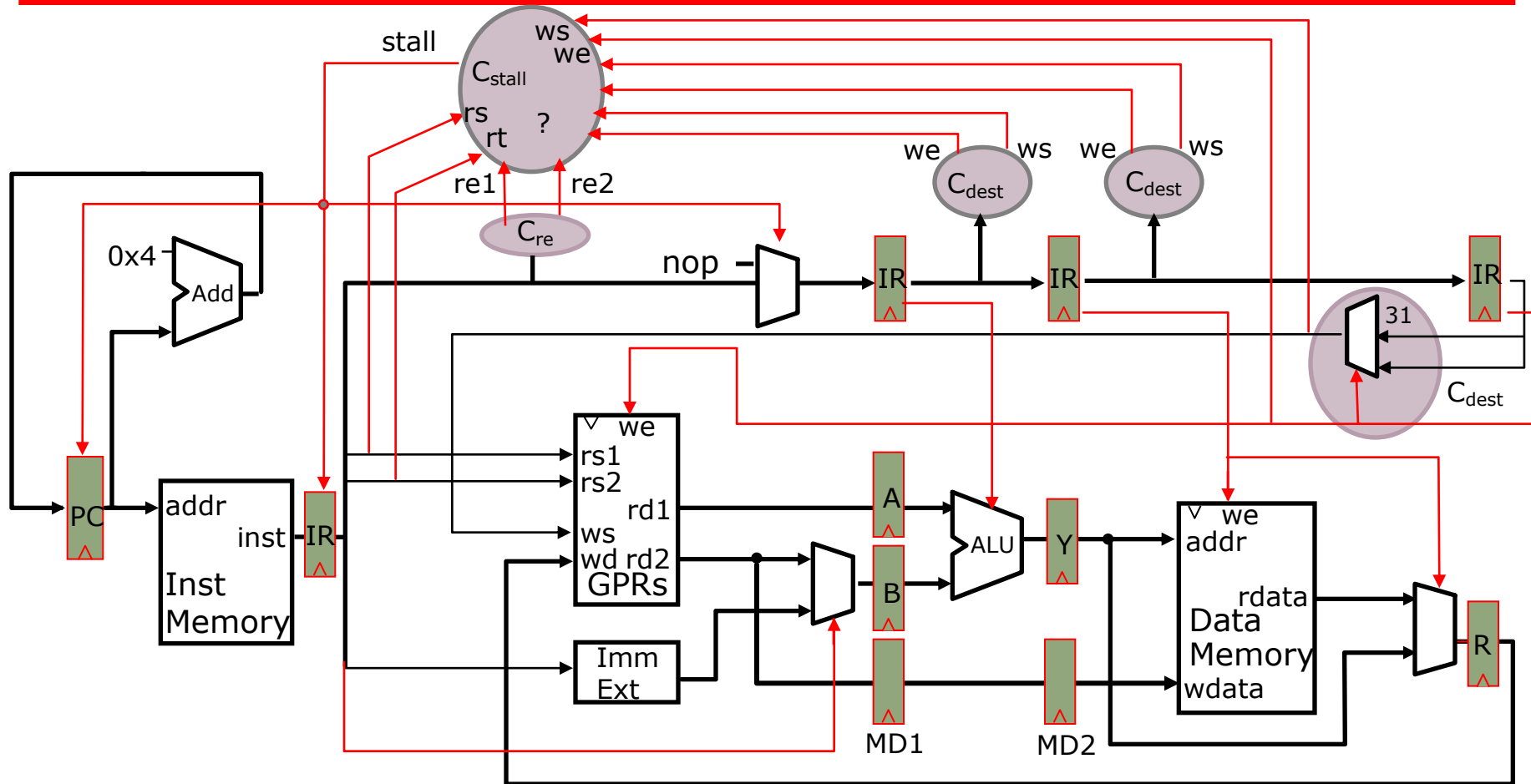

Should we always stall if the rs field matches some rd?

Thank you!