

6.823  
Computer System Architecture  
Lab 2

*Assigned Feb. 28, 2014*

Worth 5% of Course Grade

*Due Mar. 31, 2014*

---

<http://csg.csail.mit.edu/6.823/>

---

***Warning: This lab will likely take substantially longer to complete than Lab 1. Do not put it off until the last minute. The simulations alone will take a few hours to run.***

## Summary

The memory bottleneck is one of the paramount design concerns in modern processors. As we saw in lecture, while processor speeds have increased exponentially over the last 30 years, main memory speeds have only increased linearly since memories have been optimized for capacity rather than latency. Since memories are slow relative to the processor and memory accesses are frequent (one per loaded instruction!), a major area of architectural research is improving the perceived latency of the memory.

In order to improve the perceived latency of memory accesses, we, as architects, must first understand the nature of memory accesses. It has been the experience of architects that software memory accesses exhibit high temporal and spatial locality. Temporal locality means that the accessed memory location is likely to be accessed again in the near future. Spatial locality means that memory locations near the address of the accessed memory location are likely to be accessed in the near future.

In this lab, we will explore the concept of memory caching which is a common and highly effective mechanism for improving memory latency. A cache is a fast, but necessarily small memory that contains recently accessed areas of memory. The cache has a much lower access and update latency than the main memory; thus, if the memory locations that the process requires are present in the cache, the processor can obtain the data in a small number of cycles (as opposed to the many hundreds of cycles it would take to access the main memory), thereby improving processor performance. Since we ultimately measure the performance of the cache by its usefulness, which is the percentage of time that it is able to satisfy processor requests, statistics like write hit percentage and read hit percentage are often used to evaluate caches.

In this lab, we will evaluate the behavior of various cache organizations using Pin and the SPEC benchmarks.

As always, this lab is to be completed individually. You are encouraged to discuss lab concepts with fellow classmates.

## Setting up

First, as for Lab 1, set up your environment for Pin. You'll need to do this each time you log in to work on the labs.

```
% add 6.823
% source /mit/6.823/Spring14/setup.csh (or setup.sh)
```

To obtain the materials for lab 2, use the following commands, **assuming that you start in your individual repository (cd \$USER) from the previous lab:**

```
% svn export $LAB2ROOT
% svn add lab2handout
% svn commit -m "Lab 2 Initial Check-in"
```

In the lab2handout directory that just got created, you should find a make file, some sample source code, and a test script. Type the following at the command prompt:

```
% cd lab2handout
% make
```

Make will build the caches Pin tool. Attempting to run the Pin tool will result in a failure message, stating that no Pin tool has been implemented. The caches Pin tool can be invoked from the command line in the following manner:

```
% pin -t caches - [target_executable]
```

We have provided a test perl script lab2test.pl. The perl script will invoke Pin using the caches Pintool on multiple SPEC binaries. To invoke the perl script, type:

```
% ./lab2test.pl
```

Although we provide a script that will test your Pin tool, the script will not verify your Pin tool, and we will not release the expected results of the test cases (which is what would happen in industry if you were designing the next-generation microarchitecture). Further, we reserve the right to run test cases not included in the released test script. You are encouraged to compare your results with your classmates.

## Lab Task

The purpose of this lab is to generate a set of parametric cache models that will help us analyze the behavior of various cache configurations. A cache can be described in terms of a relatively small number of parameters. We can view a cache as a data array containing  $R$  rows (or *sets*), each of which contains  $A$  (the set associativity or *ways*) data blocks of size  $B$  and some metadata (tag, valid bit) about  $B$ . When the data array is presented an address, it outputs the associated block data. The address can be broken down as  $\langle \text{tag} \rangle \langle \text{index or row} \rangle \langle \text{block offset} \rangle$ .

The index bits are used to access a particular row of the cache. Each cache also defines a replacement policy that determines which existing block in a row to evict on a cache fill. Commonly used replacement policies include random replacement, least-recently-used, and not most-recently-used. The following diagram depicts cache organization in terms of these parameters.

The behavior and implementation of the cache will also depend on some system-wide parameters. The caches that use virtual addresses must know the size of a memory

page in the system; depending on the hardware the size of virtually indexed cache may be constrained by this parameter (Why?). Although the size of the physical memory does not affect cache organization, it will affect cache performance as pages are swapped in and out of the physical memory.

In the lab, you will design a set of parameterized L1 data cache models based on the diagram. It should be pointed out in the diagram that the input memory addresses accessed could be either virtual or physical. We will cover the distinction between virtual and physical addresses in class soon. We will experiment with both styles of cache in this lab.

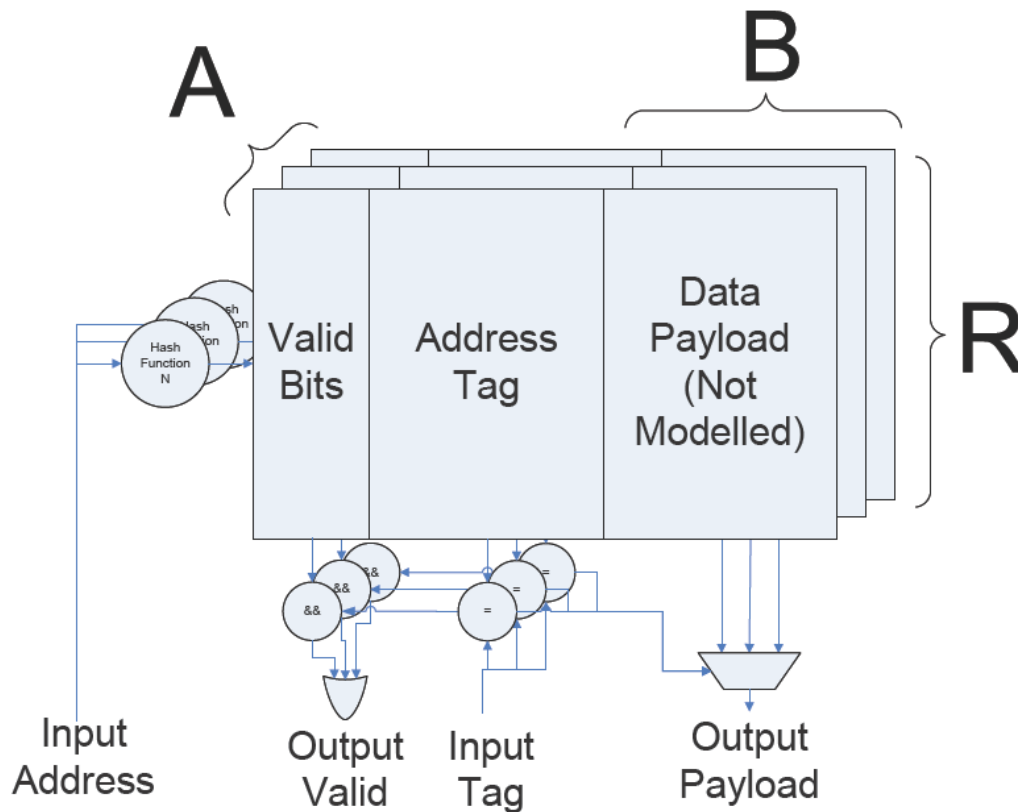

Parametric Cache Model

With all of the above background, we can discuss the starter code, which is located in `caches.cpp`. All the caches that you will implement will inherit the `CacheModel` base class. Notice that the base class implements some of the cache metadata for you, although you will have to add some metadata of your own. The following is a description of the `CacheModel` functions. You are expected to implement the bold faced functions for each cache.

**readReq:** This function is a read request from the processor to the cache. The processor will present a virtual address. You will then update the appropriate cache metadata, according to the cache type.

**writeReq:** This function is a write request from the processor to the cache. The processor will present a virtual address. You will then update the appropriate cache metadata, according to the cache type.

`dumpResults`: This function will print out the cache statistics that `readReq` and `writeReq` have been tracking. We will call this function at the end of the `Pin` run from the code that we have provided you. Don't modify this code or you'll break our testbenches, which will be tragic for the correctness portion of your lab grade.

The lab assumes 32-bit Virtual Addresses, and `logPhysicalMemSize`-bit Physical Addresses. The following global function will be used to translate between virtual and physical addresses:

`getPhysicalPageNumber`: This function translates virtual page numbers from `Pin` into 'physical' page numbers, akin to the translation look-aside buffer and page table. It produces physical page numbers of size  $(\text{logPhysicalMemSize} - \text{logPageSize})$ . You should note that different virtual addresses may map to the same physical address (aliasing). *You do not need to worry about solving this in your implementation.*

In this lab you will implement the above two functions which will track the cache metadata, thereby simulating the behavior of a real cache. The metadata that you will track includes the cache valid bits, the cache tags, and information for the least recently used (LRU) replacement policy. Recall that least recently used replacement means that when a cache block needs to be evicted, the block that was read or written farthest in the past will be chosen for eviction. Notice that the `CacheModel` base class has a number of constructor parameters, such as `associativityParam`, `logNumRowsParam`, and `logBlockSizeParam`. You will use these parameters to implement your functions in such a way that multiple cache sizes and associativities can be tested rapidly. We use the `logVariable` naming convention to denote that the parameter is given as a base 2 logarithm of the actual size, thus if `logBlockSizeParam` is 4 then the block size is  $2^4 = 16$  bytes. Notice that our instantiations of the cache classes that you will implement use `Pin` command line parameters to obtain parameters. Thus, you can test your caches with many configurations, even though our public testbench will only examine a trivial configuration. The baseline caches that you will be implementing will use the appropriate number of low order bits of either the virtual or physical index as the hash function for accessing the rows of the ways. You should use the scheme in the above diagram to organize your cache.

You will implement three cache models, one that is virtually indexed and virtually tagged, one that is virtually indexed and physically tagged, and one that is physically indexed and physically tagged. Each cache will be an extension of the base `CacheModel` class. Each cache model will track a variety of statistics. You will track the total number of read accesses, the total number of write accesses, the number of read hits, the number of write hits. Your labs will be evaluated for accuracy based on these statistics.

As we have observed in class and in lab 1, x86 is a rather quirky architecture. Recall that MIPS and other more modern architectures allow only aligned memory accesses. Aligned memory accesses means that the bottom bits of the address of the requested data must be zero. Thus, the address of a four-byte access must always end in `2'b00`. X86, however, allows unaligned memory accesses, which will introduce some potential inaccuracy into our cache models. We will ignore handling unaligned memory

accesses by assuming that the appropriate bottom bits of the access address are zeroed out. This implies that all accesses to the cache will fall within the same cache block.

Although your solution will not be graded on its performance in terms of wall clock time, you should note that your Teaching Assistants are impatient people. The TA solution runs the sample testbench in less than one hour on the class machines (with nominal load). For grading purposes, we will allow your pin tool to run for an order of magnitude more time than ours requires (around 10 hours). After ten hours, we will kill it and assign a grade based on progress to that point. Do not write horrendously inefficient code: it makes kittens sad.

We have provided you an additional script to enable you to run all the SPEC binaries for different cache configurations from command line.

```
% ./lab2test_param.pl -b <logBlockSize> -r <logNumRows> -a <associativity>
```

When you have completed the lab to your satisfaction, submit your changes to the svn repository. The deadline for submission is 23:59:59 EDT 31 March 2014. We'll grade whatever code you have checked in by the deadline. **No Late Submissions will be accepted!** Seriously.

## Lab Questions

Your response to the lab questions should be typed in lab2questions.pdf (or lab2questions.doc) in the lab2handout directory. The course material necessary to answer some of the questions will be covered after the distribution of this handout, so if some of the material looks foreign, it probably just hasn't been covered yet. Some questions may require coding, and as such should not be put off until the last minute.

**1. Hit and miss.** Using your physically indexed, physically tagged cache model, starting from a base configuration (Rows = 512, Block Size = 4 bytes, Associativity = 1), vary the number of rows, block size, associativity, and capacity of your cache models. Can you explain any general trends in hit and miss rate that you observe (show graphs). Are there significant differences between the three cache models? Why?

**2. SPEC interrogation.** Using your physically indexed, physically tagged cache model, determine the size of the working set (lookup what it means) for the SPEC2000 benchmarks, justifying your answer with a graph. Are the working sets of the SPEC benchmarks intended to fit in a processor cache (lookup the typical sizes of L1 these days)? Why or why not? Do you notice a difference between the SPECINT and SPEC FP programs in terms of hit and miss rates? Explain why this difference occurs. Would you choose different cache configurations (block size, associativity and number of rows) given the same cache size, for floating point programs and integer programs? Which configuration(s) would you choose and why? (Remember that an associative cache takes more chip area and power than a direct mapped cache of the same capacity).

**3. Make the common case fast.** We asked you to implement three cache models. A potential fourth cache model is a physically indexed, virtually tagged cache. Does this cache configuration make sense? Explain why or why not. Take timing issues in to account.

**4. Make the uncommon case correct.** Ignore the aliasing problem for this question. Although our baseline test bench only behaves as if the simulated machine has a single process running, real machines almost always have more than one process at a time (Hmm... I wonder if the TA will test this case? Hmm...). Uh-oh, it seems like one of the cache models may not work in the presence of multiple processes. Which one, and why? Given a page size of 256 bytes and a cache size of 512 bytes write down the cache configurations (block size, index, associativity etc) that will work for each cache model. Explain what modifications are necessary to make each cache model work in the presence of multiple processes.

**5. You assume too much.** We assumed that all memory accesses were aligned. Design a simple experiment to determine how many unaligned memory accesses occur in the SPEC benchmarks. Does our assumption make sense? Can you explain the frequency of unaligned accesses?

When you have answered these questions to your satisfaction, put them in a file called lab2questions.pdf (or lab2questions.doc) in your lab2handout directory, then run the following to add them and commit them.

```
% svn add lab2questions.pdf
% svn commit -m "Lab 2 Questions Check-In"
```

As with the lab code, we'll grade whatever you have checked in by the deadline.

## Lab Grading

10%: Submission compiles  
20%: Submission passes public test bench  
20%: Submission passes private test bench  
50%: Quality of lab question responses

## Advice on Mine Sweeping

There may be bugs in either our code or infrastructure. If you notice any 'interesting' or 'unexpected' behavior it could be a problem in the code or infrastructure that we provided. Report these bugs immediately to the TA, preferably in an email with the subject 6.823 Bug Report. This will help to ensure prompt fixing of any issues that may arise.