



Advanced Memory Operations

Joel Emer

Computer Science and Artificial Intelligence Laboratory
Massachusetts Institute of Technology

<http://www.csg.csail.mit.edu/6.823>

Direct-Mapped Cache

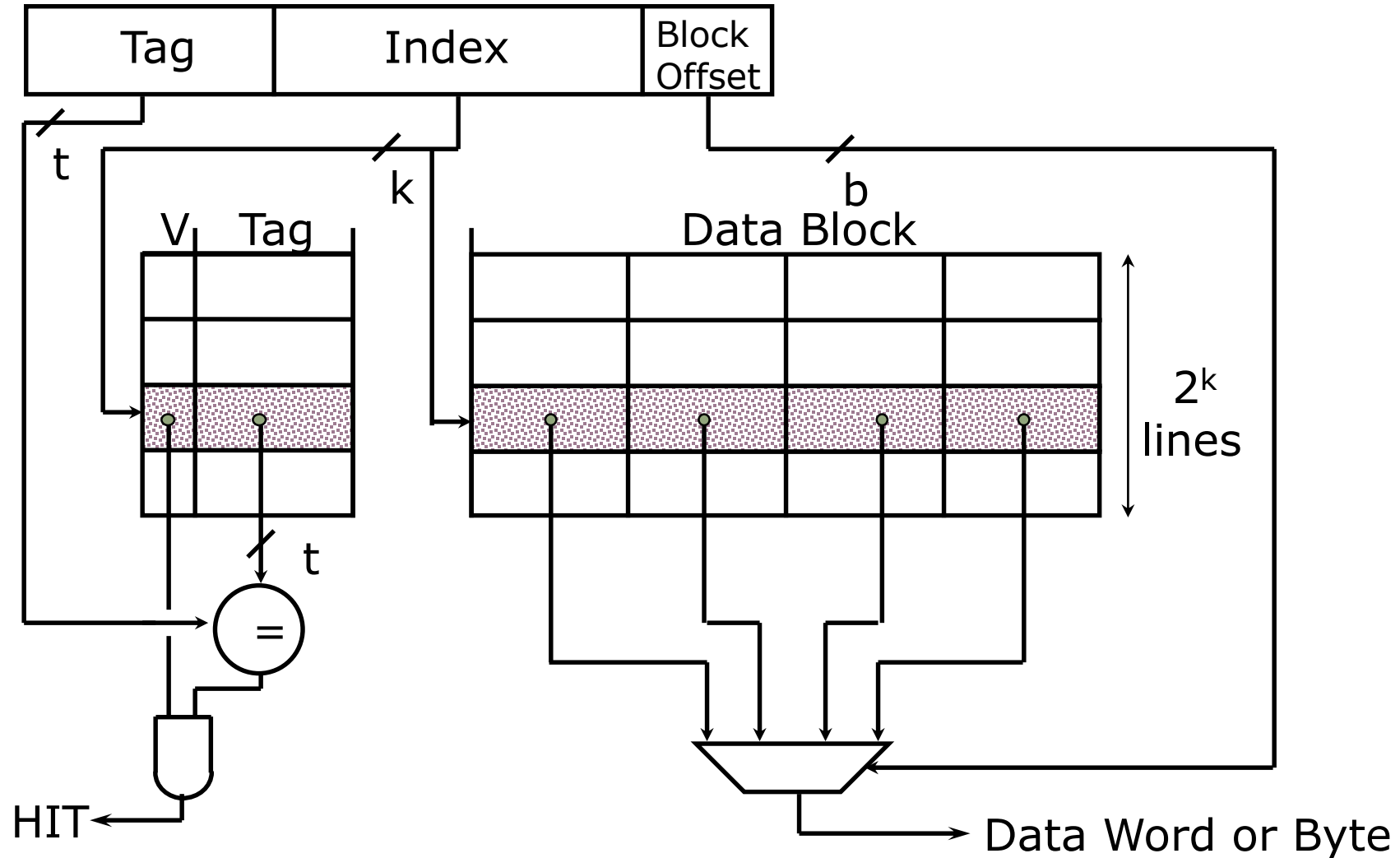

Write Performance

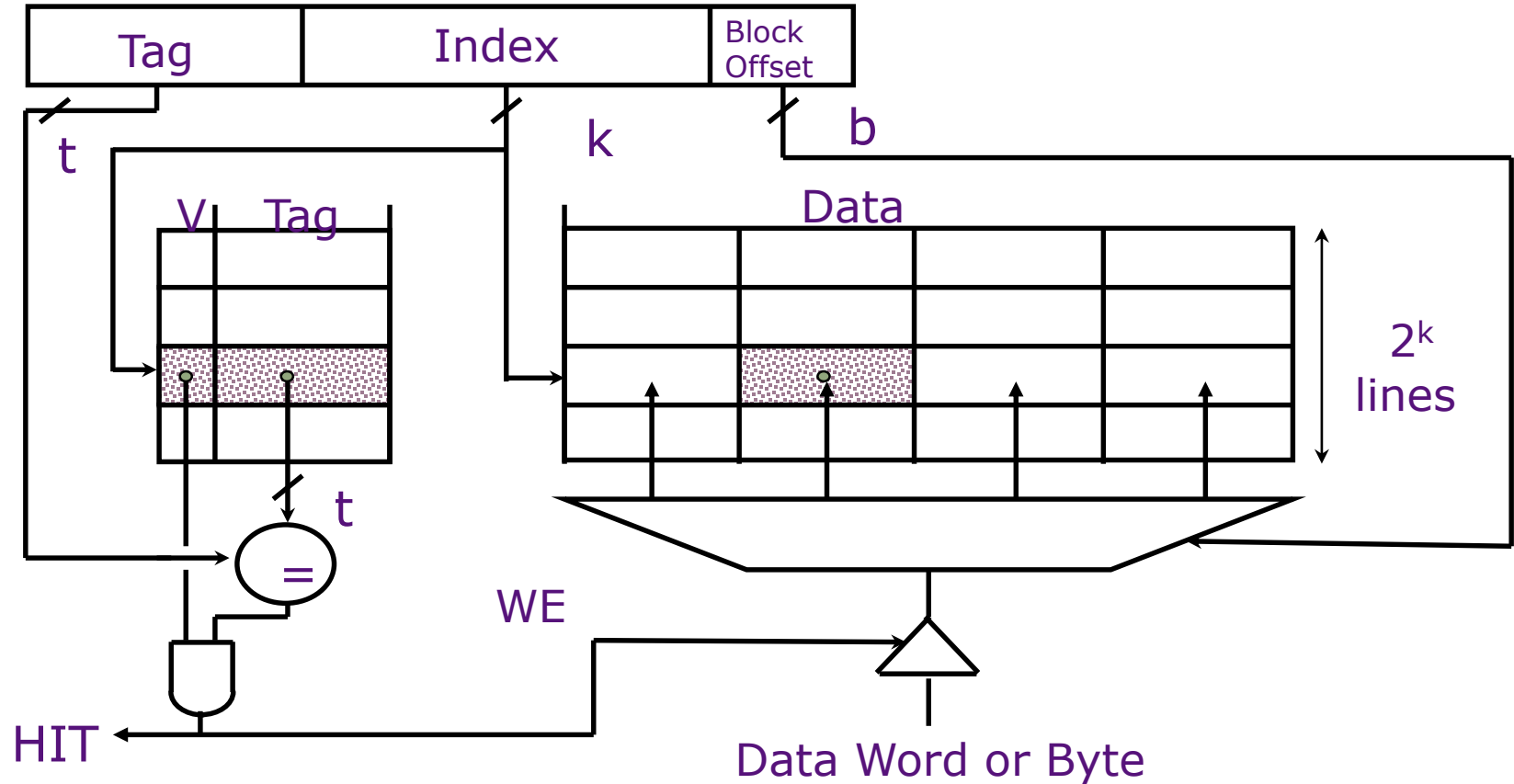

How does write timing compare to read timing?

Completely serial!

Reducing Write Hit Time

Problem: Writes take two cycles in memory stage, one cycle for tag check plus one cycle for data write if hit

View: Treat as data dependence on micro-architectural value 'hit/miss'.

Solutions:

- Wait – delivering data as fast as possible:
 - Fully-associative (CAM Tag) caches: Word line only enabled if hit
- Speculate predicting hit with greedy data update:
 - Design data RAM that can perform read and write in one cycle
 - Restore old value after tag miss (abort)
- Speculate predicting miss with lazy data update:
 - Hold write data for store in single buffer ahead of cache
 - Write cache data during next idle data access cycle (commit)

Pipelined/Delayed Write Timing

Problem: Need to commit lazily saved write data

Solution: Write data during idle data cycle of next store's tag check

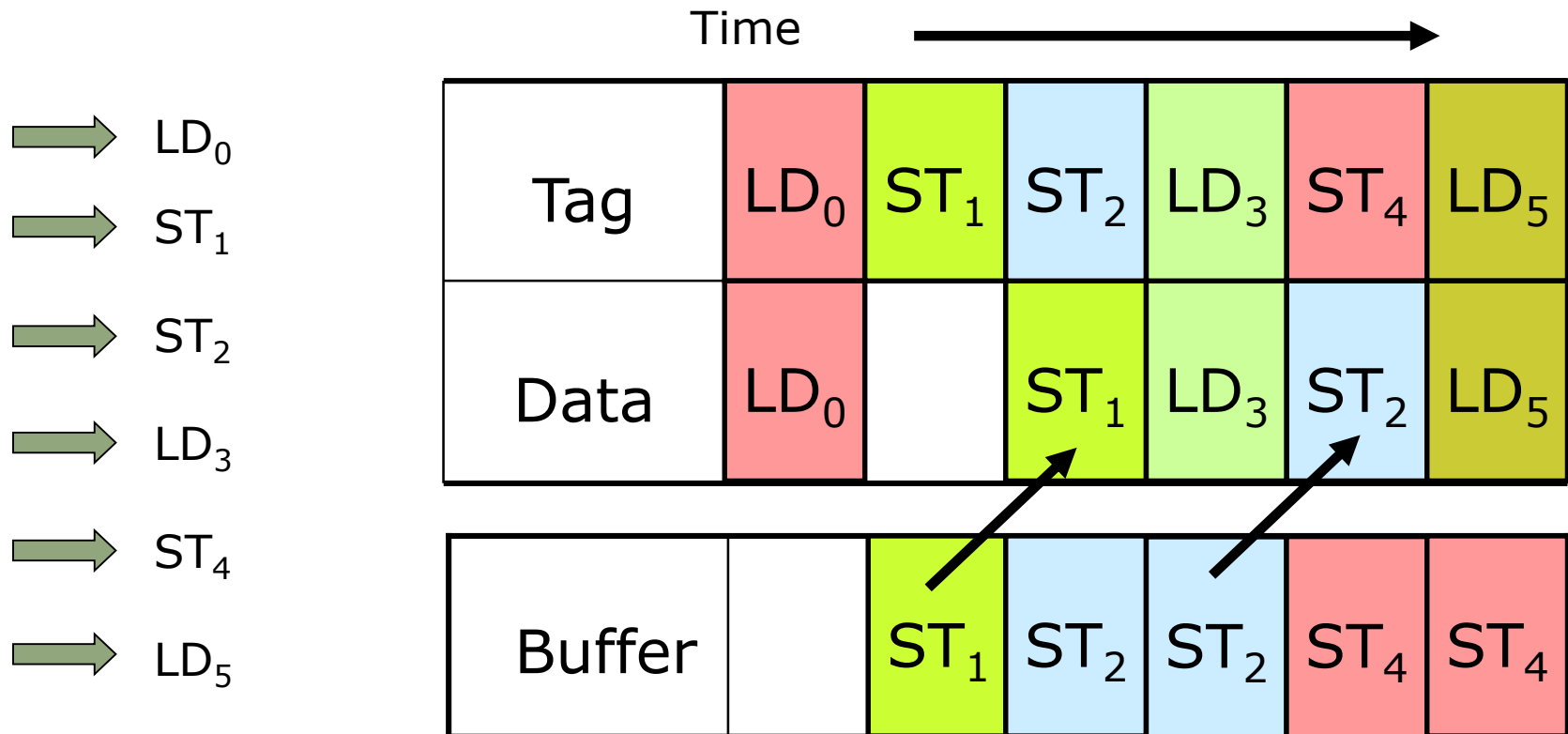

Pipelining Cache Writes

What if instruction needs data in delayed write buffer?

Bypass

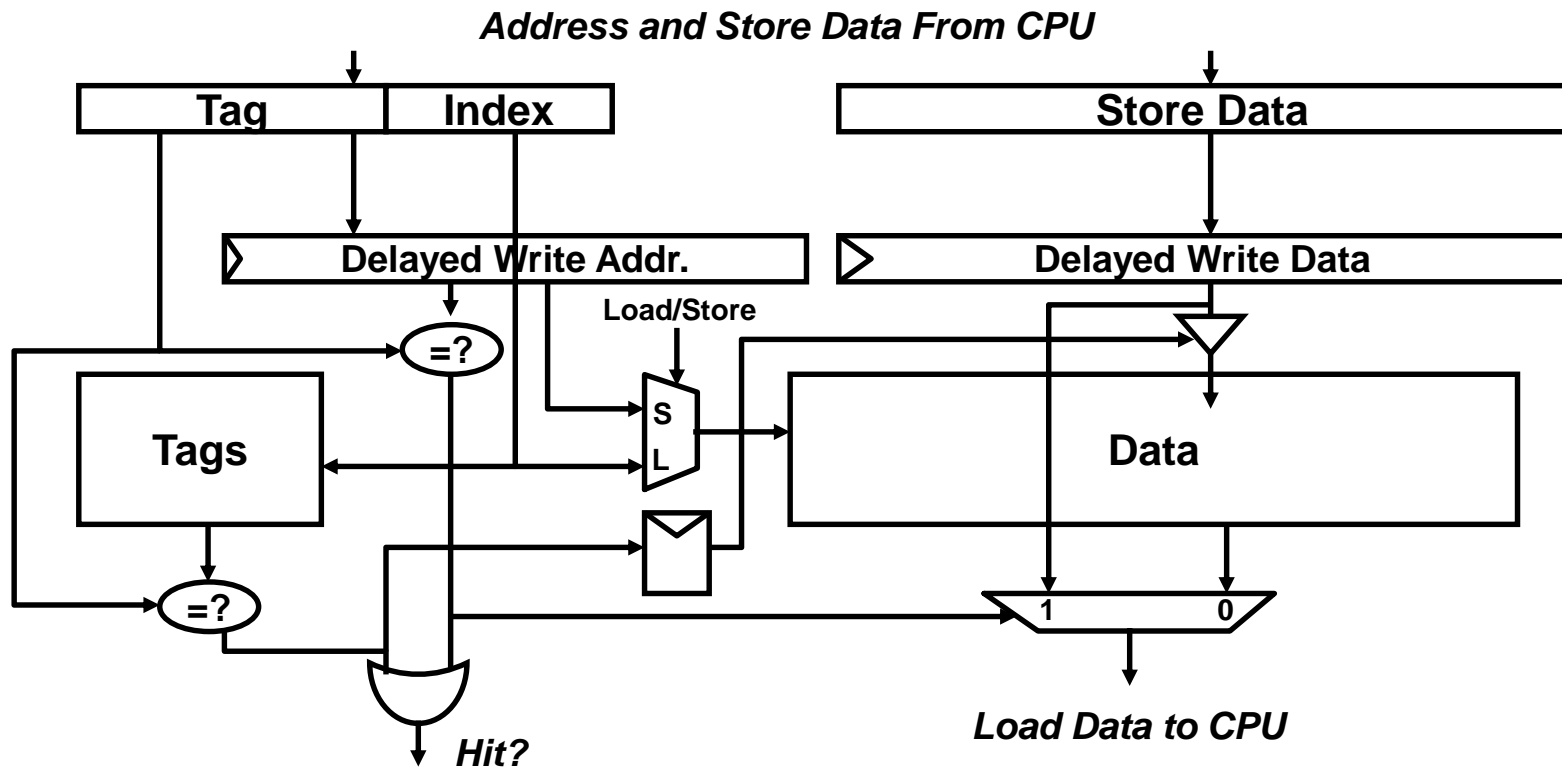

Write Policy Choices

- Cache hit:
 - **write through:** write both cache & memory
 - generally higher traffic but simplifies cache coherence
 - **write back:** write cache only
(memory is written only when the entry is evicted)
 - a dirty bit per block can further reduce the traffic
- Cache miss:
 - **no write allocate:** only write to main memory
 - **write allocate** (*aka fetch on write*): fetch into cache
- Common combinations:
 - write through and no write allocate
 - write back with write allocate

Reducing Read Miss Penalty

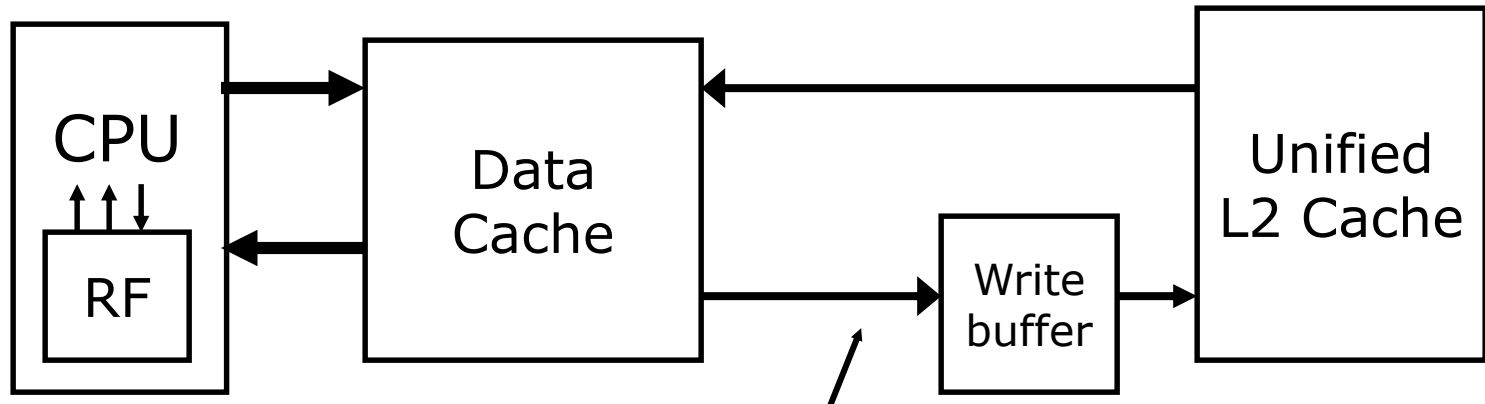

Evicted dirty lines for writeback cache
OR
All writes in writethru cache

Problem: Write buffer may hold updated value of location needed by a read miss – RAW data hazard

Stall: on a read miss, wait for the write buffer to go empty

Bypass: Check write buffer addresses against read miss addresses, if no match, allow read miss to go ahead of writes, else, return value in write buffer

O-o-O With Physical Register File

(MIPS R10K, Alpha 21264, Pentium 4)

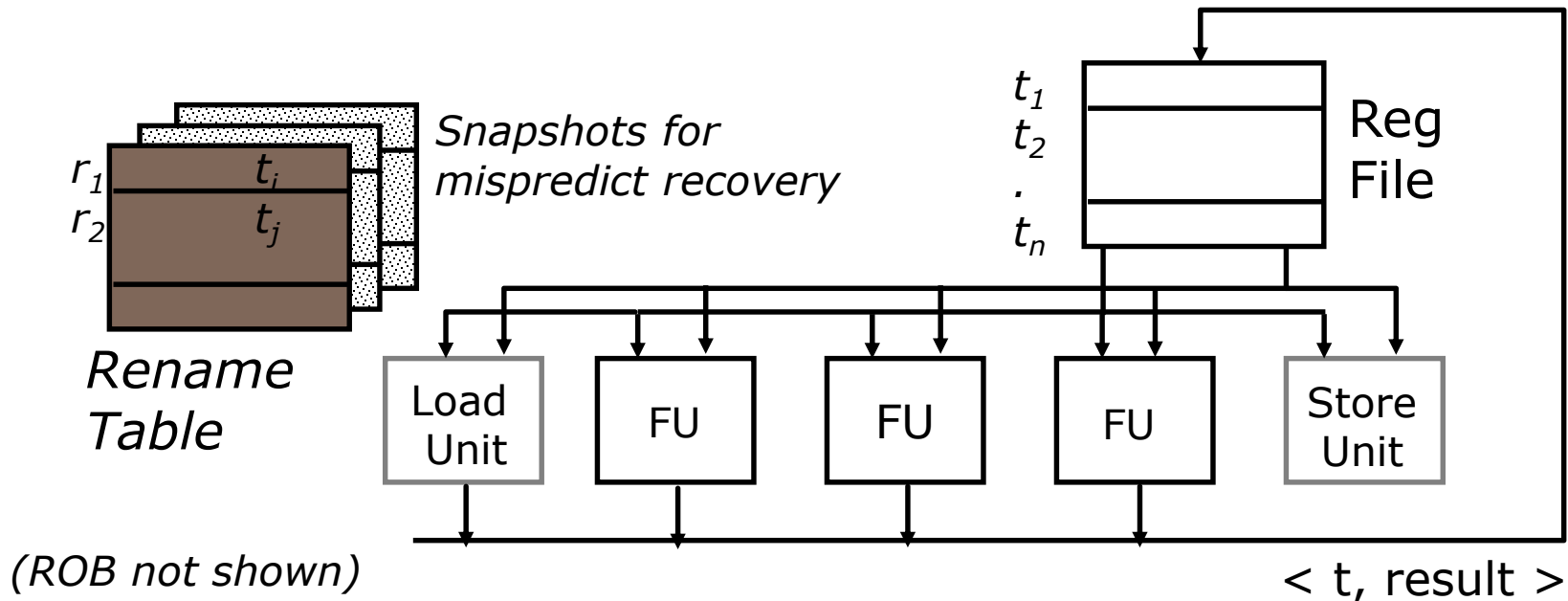

We've handled the register dependencies, but what about memory operations?

Speculative Loads / Stores

Problem: Just like register updates, stores should not permanently change the architectural memory state until after the instruction is committed

Choice: Data update policy: greedy or lazy?

Lazy: A speculative store buffer is a structure introduced to lazily hold speculative store data.

Choice: Handling of store-to-load data hazards: stall, bypass, speculate...?

Bypass: ...

Store Buffer Responsibilities

- **Lazy store of data:** Log new data values for stores
- **Commit/abort:** The data from the oldest instructions must either be committed to memory or forgotten.
- **Bypass:** Data from older instructions must be provided (or forwarded) to younger instructions before the older instruction is committed

Commits are generally done in order – why?

WAW Hazards

Store Buffer – Lazy data management

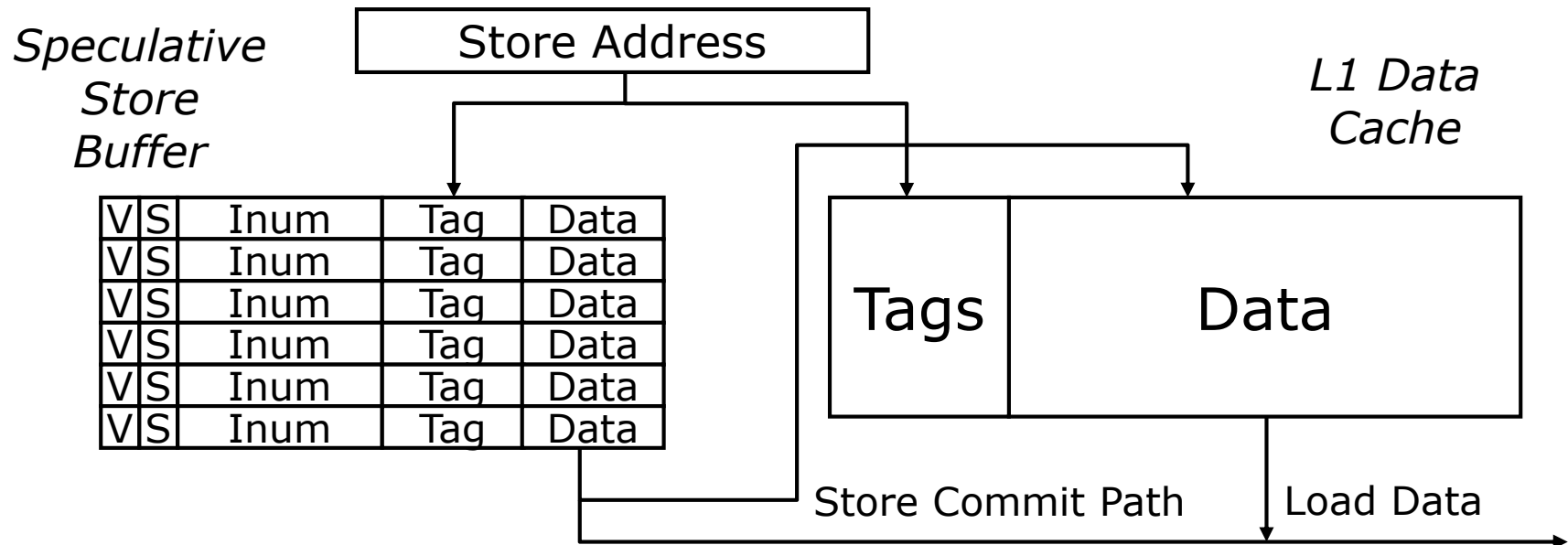

- On store execute:
 - mark valid and speculative; save tag, data and instruction number.
- On store commit:
 - clear speculative bit and eventually move data to cache
- On store abort:
 - clear valid bit

Store Buffer - Bypassing

Load Address

What fields must be examined for bypassing?

Valid, Inum and tag

V	S	Inum	Tag	Data
V	S	Inum	Tag	Data
V	S	Inum	Tag	Data
V	S	Inum	Tag	Data
V	S	Inum	Tag	Data
V	S	Inum	Tag	Data

- If data in both store buffer and cache, which should we use:
Speculative store buffer - if store older than load
- If same address in store buffer twice, which should we use:
Youngest store older than load
- Calculating entry needed in the store buffer can be considered a dependence on accessing the store buffer. So store buffer bypassing can be managed speculatively by building a simple predictor that guesses that the specific entry in the store buffer the load needs. So what happens if we guessed the wrong entry:
Declare a mis-speculation and abort.

Memory Dependencies

For registers we used tags or physical register numbers to determine dependencies. What about memory operations?

st r1, (r2)

ld r3, (r4)

When is the load dependent on the store?

When $r2 == r4$

Does our ROB know this at issue time? **No**

In-Order Memory Queue

```
st r1, (r2)
ld r3, (r4)
```

Stall naively:

- Execute all loads and stores in program order

=> Load and store cannot leave ROB for execution until all previous loads and stores have completed execution

- Can still execute loads and stores speculatively, and out-of-order with respect to other instructions

Conservative O-o-O Load Execution

```
st r1, (r2)
ld r3, (r4)
```

Stall intelligently:

- Split execution of store instruction into two phases: address calculation and data write
- Can execute load before store, if addresses known and $r4 \neq r2$
- Each load address compared with addresses of all previous uncommitted stores (*can use partial conservative check i.e., bottom 12 bits of address*)
- Don't execute load if any previous store address not known

(MIPS R10K, 16 entry address queue)

Address Speculation

```
st r1, (r2)
ld r3, (r4)
```

1. Guess that $r4 \neq r2$, and execute load before store address known
2. If $r4 \neq r2$ commit...
3. But if $r4 == r2$, squash load and *all* following instructions
 - To support squash we need to hold all completed but uncommitted load/store addresses/data in program order

How do we resolve the speculation, i.e., detect when we need to squash?

Watch for stores that arrive after load that needed its data.

Speculative Load Buffer

Speculation check:

Detect if a load has executed before an earlier store to the same address – missed RAW hazard

Speculative Load Buffer

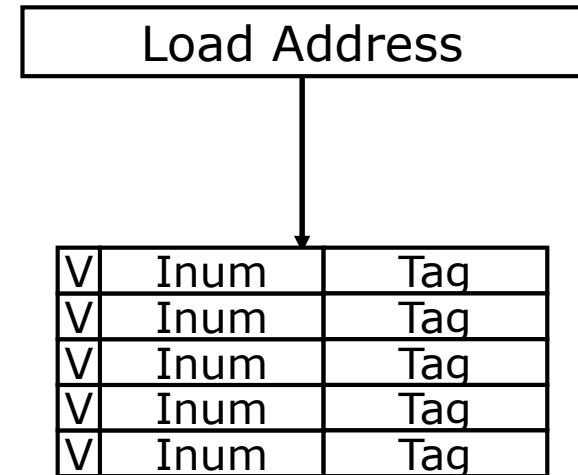

- On load execute:
 - mark entry valid, and instruction number and tag of data.
- On load commit:
 - clear valid bit
- On load abort:
 - clear valid bit

Speculative Load Buffer

*Speculative
Load Buffer*

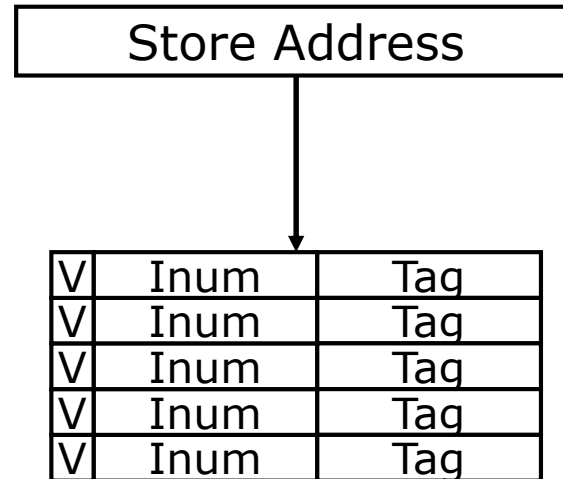

- If data in load buffer with instruction younger than store:
 - Speculative violation – abort!

=> Large penalty for inaccurate address speculation

Does tag match have to be perfect?

No!

Memory Dependence Prediction

(Alpha 21264)

```
st r1, (r2)
```

```
ld r3, (r4)
```

1. Guess that $r4 \neq r2$ and execute load before store
2. If later find $r4 = r2$, squash load and all following instructions, but mark load instruction as *store-wait*
 - Subsequent executions of the same load instruction will wait for all previous stores to complete
 - Periodically clear *store-wait* bits

Notice the general problem of predictors that learn something but can't unlearn it

Store Sets

(Alpha 21464)

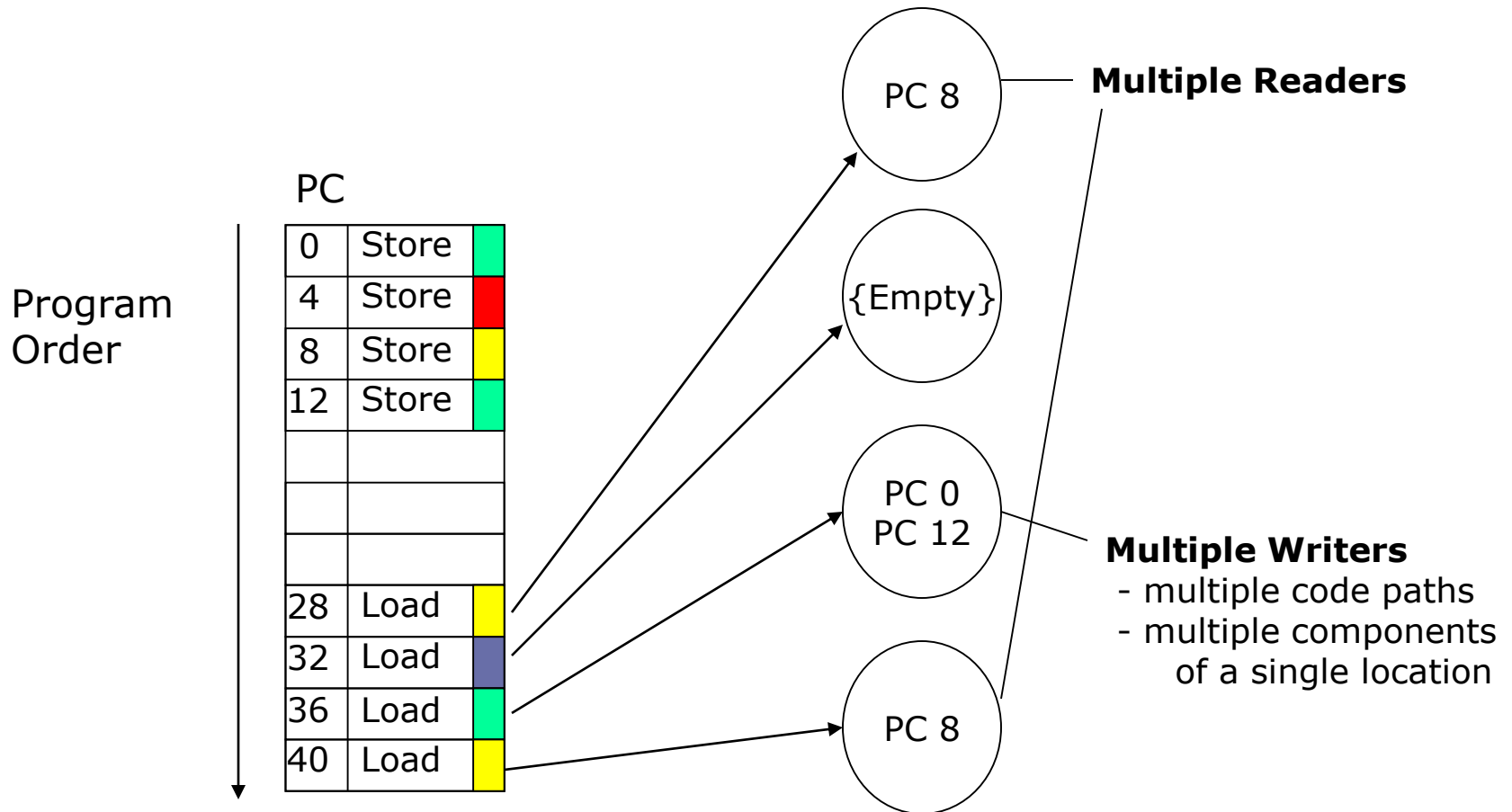

Memory Dependence Prediction using Store Sets

- A load must wait for any stores in its *store set* that have not yet executed.
- The processor approximates each load's *store set* by initially allowing naïve speculation and recording memory-order violations.

The Store Set Map Table

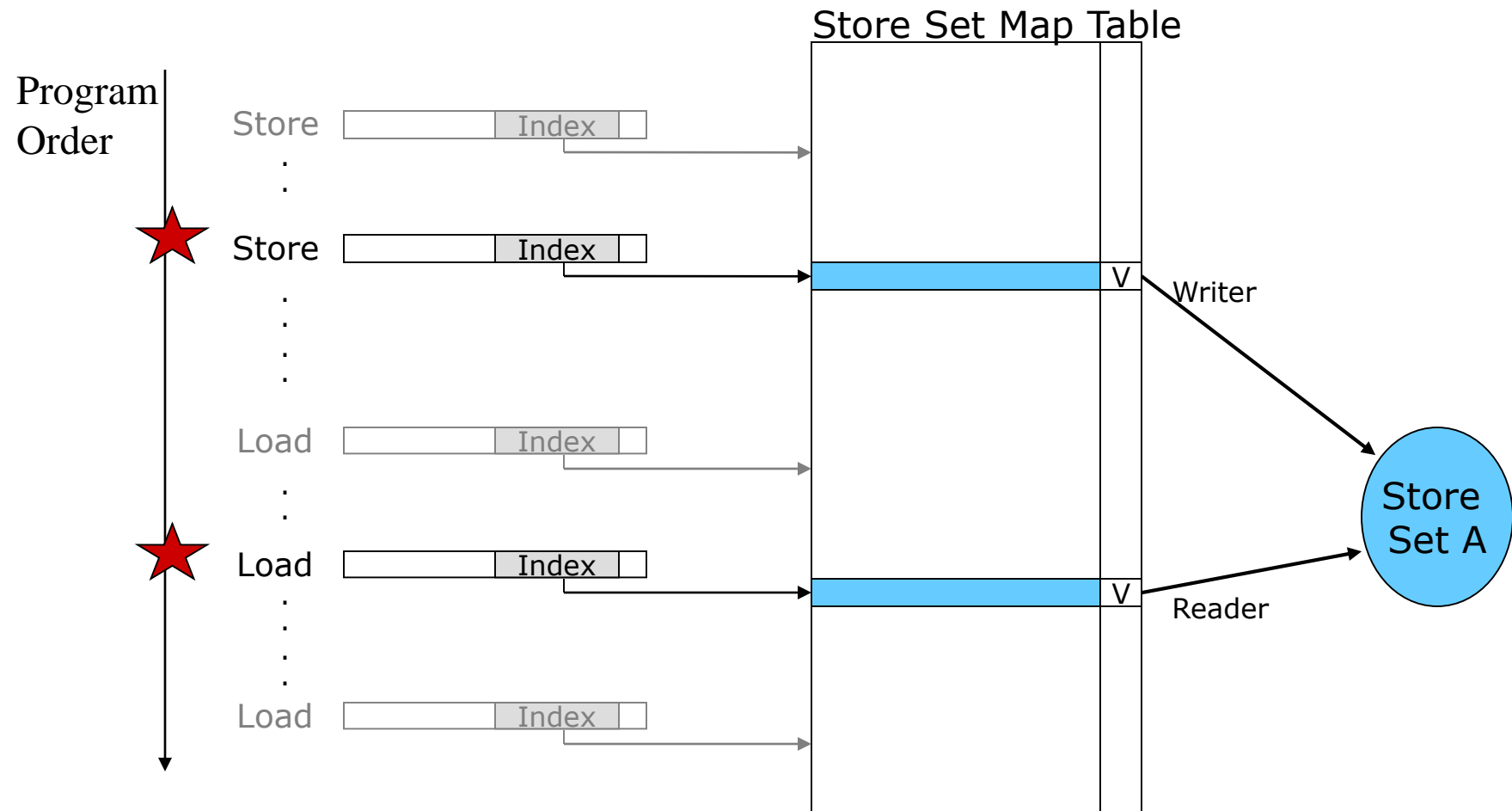

★ - Store/Load Pair causing Memory Order Violation

Store Set Sharing for Multiple Readers

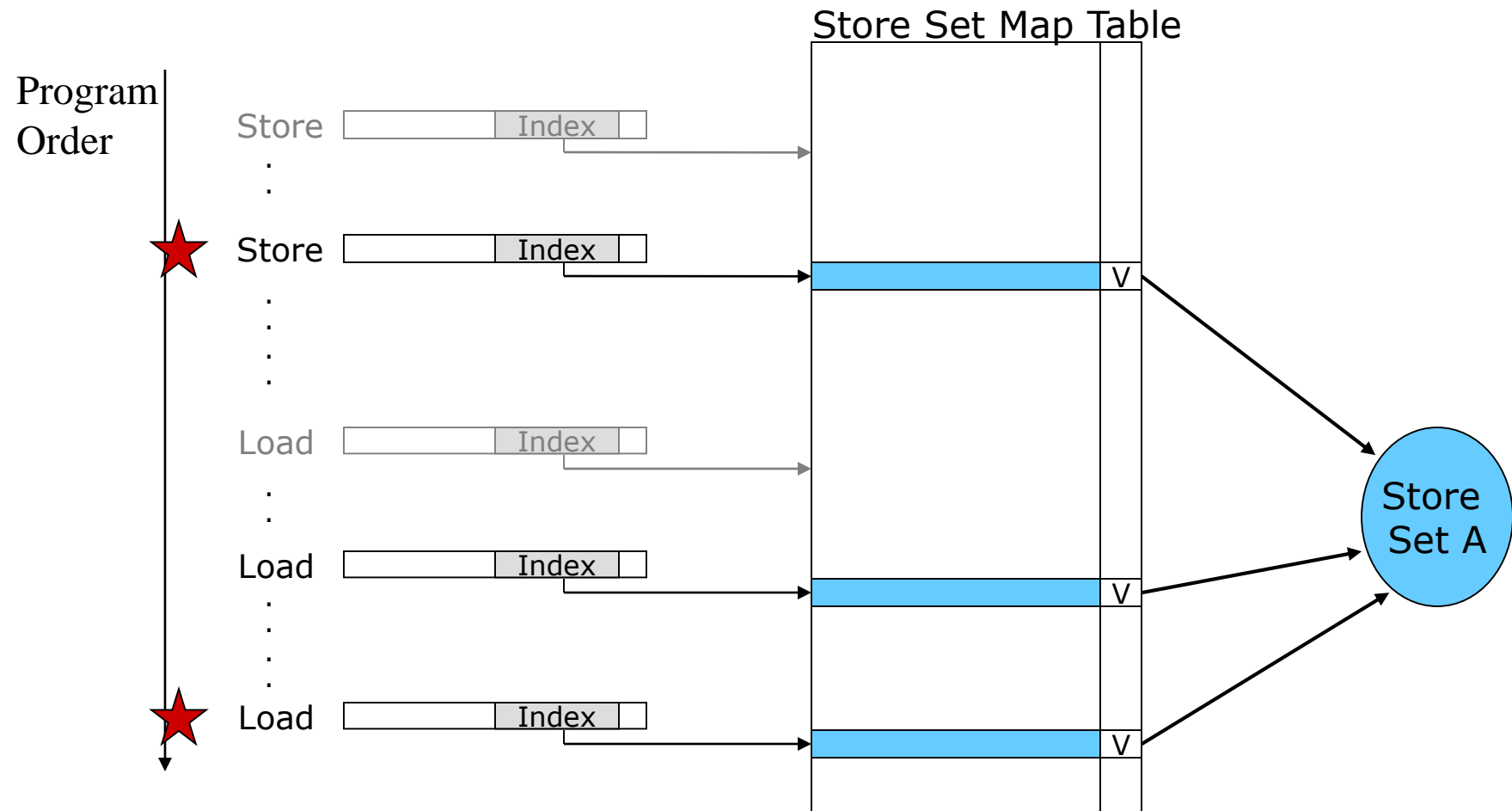

★ - Store/Load Pair causing Memory Order Violation

Store Set Map Table, cont.

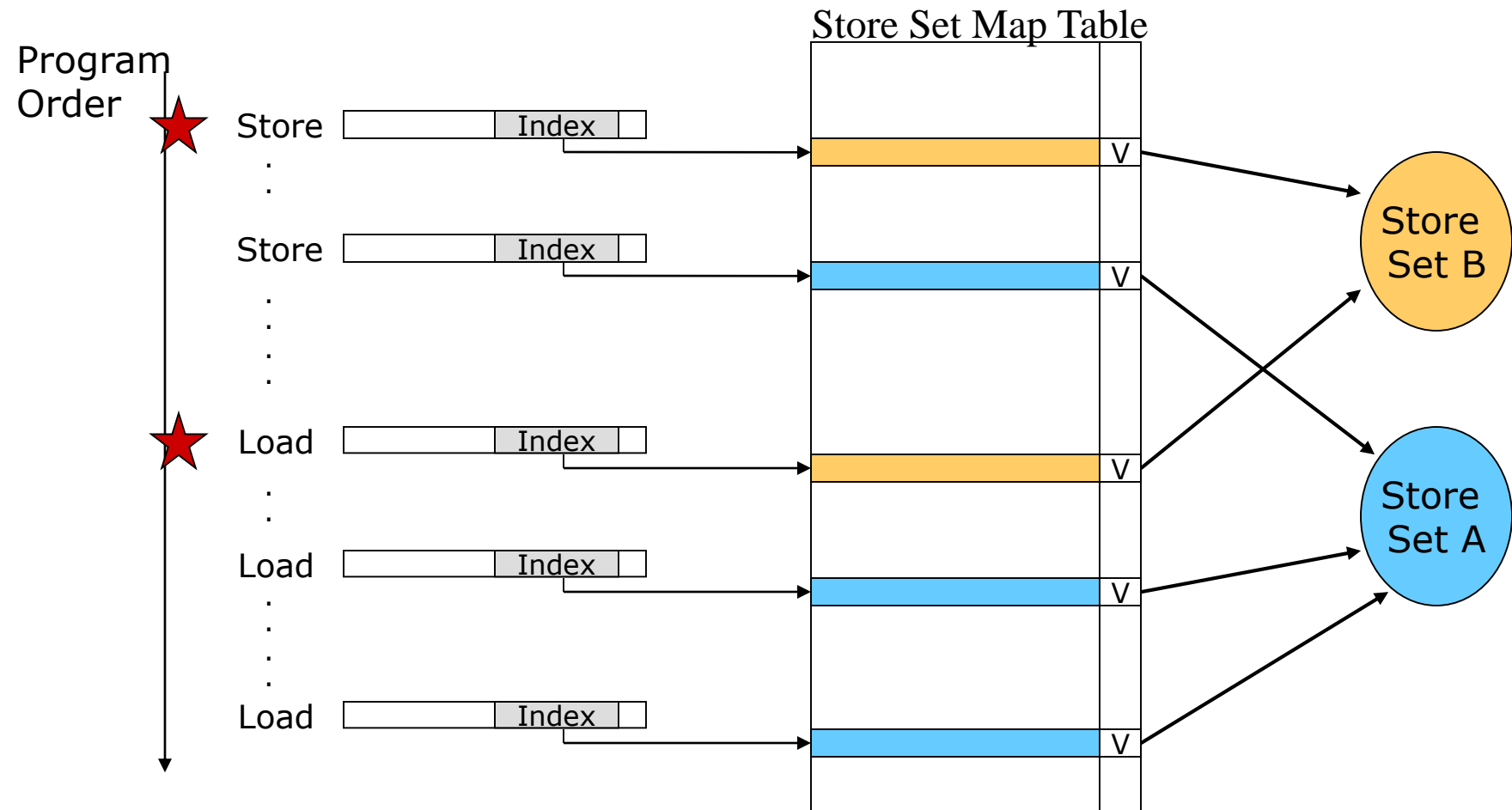

★ - Store/Load Pair causing Memory Order Violation

Prefetching

- Speculate on future instruction and data accesses and fetch them into cache(s)
 - Instruction accesses easier to predict than data accesses
- Varieties of prefetching
 - Hardware prefetching
 - Software prefetching
 - Mixed schemes
- *How does prefetching affect cache misses?*

Compulsory

Reduce

Conflict

Increase

Capacity

Increase

Issues in Prefetching

- Usefulness – should produce hits
- Timeliness – not late and not too early
- Cache and bandwidth pollution

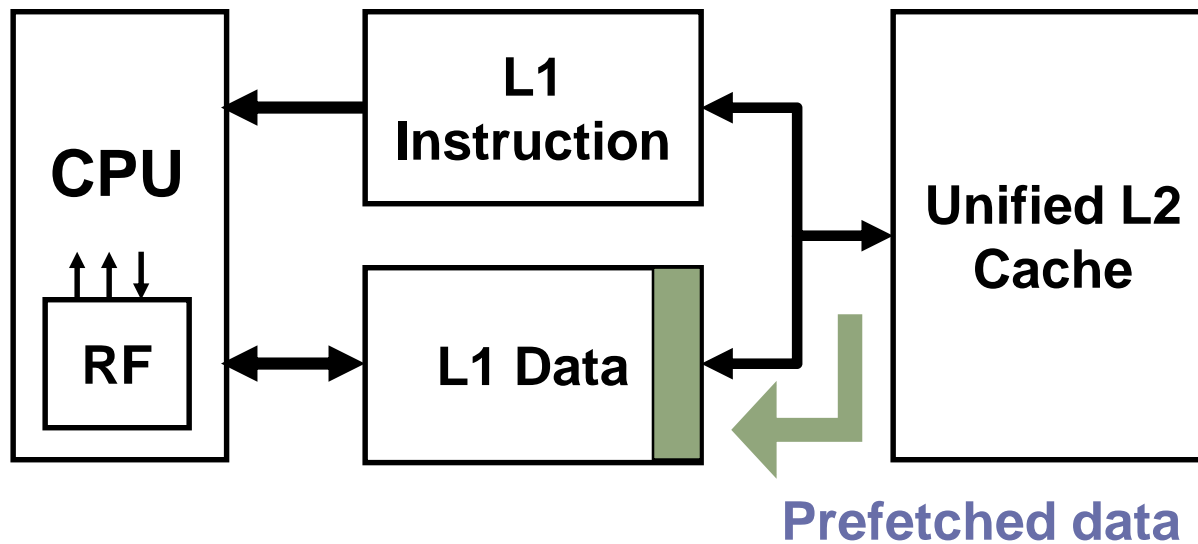

Hardware Instruction Prefetching

Instruction prefetch in Alpha AXP 21064

- Fetch two blocks on a miss; the requested block (i) and the next consecutive block (i+1)
- Requested block placed in cache, and next block in instruction stream buffer
- If miss in cache but hit in stream buffer, move stream buffer block into cache and prefetch next block (i+2)

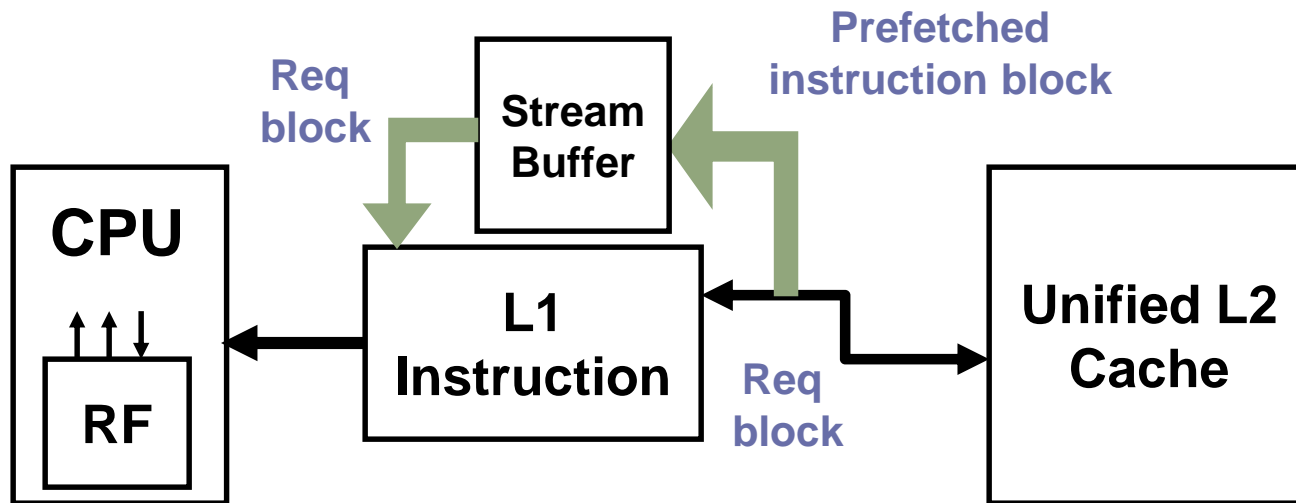

Hardware Data Prefetching

- Prefetch-on-miss:
 - Prefetch $b + 1$ upon miss on b
- One Block Lookahead (OBL) scheme
 - Initiate prefetch for block $b + 1$ when block b is accessed
 - Why is this different from doubling block size?*
 - Can extend to N block lookahead
- Strided prefetch
 - If observe sequence of accesses to block $b, b+N, b+2N$, then prefetch $b+3N$ etc.

Example: IBM Power 5 [2003] supports eight independent streams of strided prefetch per processor, prefetching 12 lines ahead of current access



Thank you !

Next lecture – multithreading