

Problem M4.1: Cache Access-Time & Performance

This problem requires the knowledge of Handout 4 (Cache Implementations) and Lecture 6 (Caches). Please, read these materials before answering the following questions.

Ben is trying to determine the best cache configuration for a new processor. He knows how to build two kinds of caches: direct-mapped caches and 4-way set-associative caches. The goal is to find the better cache configuration with the given building blocks. He wants to know how these two different configurations affect the clock speed and the cache miss-rate, and choose the one that provides better performance in terms of average latency for a load.

Problem M4.1.A

Access Time: Direct-Mapped

Now we want to compute the access time of a direct-mapped cache. We use the implementation shown in Figure H4-A in Handout #4. Assume a 128-KB cache with 8-word (32-byte) cache lines. The address is 32 bits, and the two least significant bits of the address are ignored since a cache access is word-aligned. The data output is also 32 bits, and the MUX selects one word out of the eight words in a cache line. Using the delay equations given in Table M4.1-1, fill in the column for the direct-mapped (DM) cache in the table. *In the equation for the data output driver, 'associativity' refers to the associativity of the cache (1 for direct-mapped caches, A for A-way set-associative caches).*

Component	Delay equation (ps)		DM (ps)	SA (ps)
Decoder	$200 \times (\# \text{ of index bits}) + 1000$	Tag		
		Data		
Memory array	$200 \times \log_2 (\# \text{ of rows}) + 200 \times \log_2 (\# \text{ of bits in a row}) + 1000$	Tag		
		Data		
Comparator	$200 \times (\# \text{ of tag bits}) + 1000$			
N-to-1 MUX	$500 \times \log_2 N + 1000$			
Buffer driver	2000			
Data output driver	$500 \times (\text{associativity}) + 1000$			
Valid output driver	1000			

Table M4.1-1: Delay of each Cache Component

What is the critical path of this direct-mapped cache for a cache read? What is the access time of the cache (the delay of the critical path)? To compute the access time, assume that a 2-input gate (AND, OR) delay is 500 ps. If the CPU clock is 150 MHz, how many CPU cycles does a cache access take?

Problem M4.1.B

Access Time: Set-Associative

We also want to investigate the access time of a set-associative cache using the 4-way set-associative cache in Figure H4-B in Handout #4. Assume the total cache size is still 128-KB (each way is 32-KB), a 4-input gate delay is 1000 ps, and all other parameters (such as the input address, cache line, etc.) are the same as part M4.1.A. Compute the delay of each component, and fill in the column for a 4-way set-associative cache in Table M4.1-1.

What is the critical path of the 4-way set-associative cache? What is the access time of the cache (the delay of the critical path)? What is the main reason that the 4-way set-associative cache is slower than the direct-mapped cache? If the CPU clock is 150 MHz, how many CPU cycles does a cache access take?

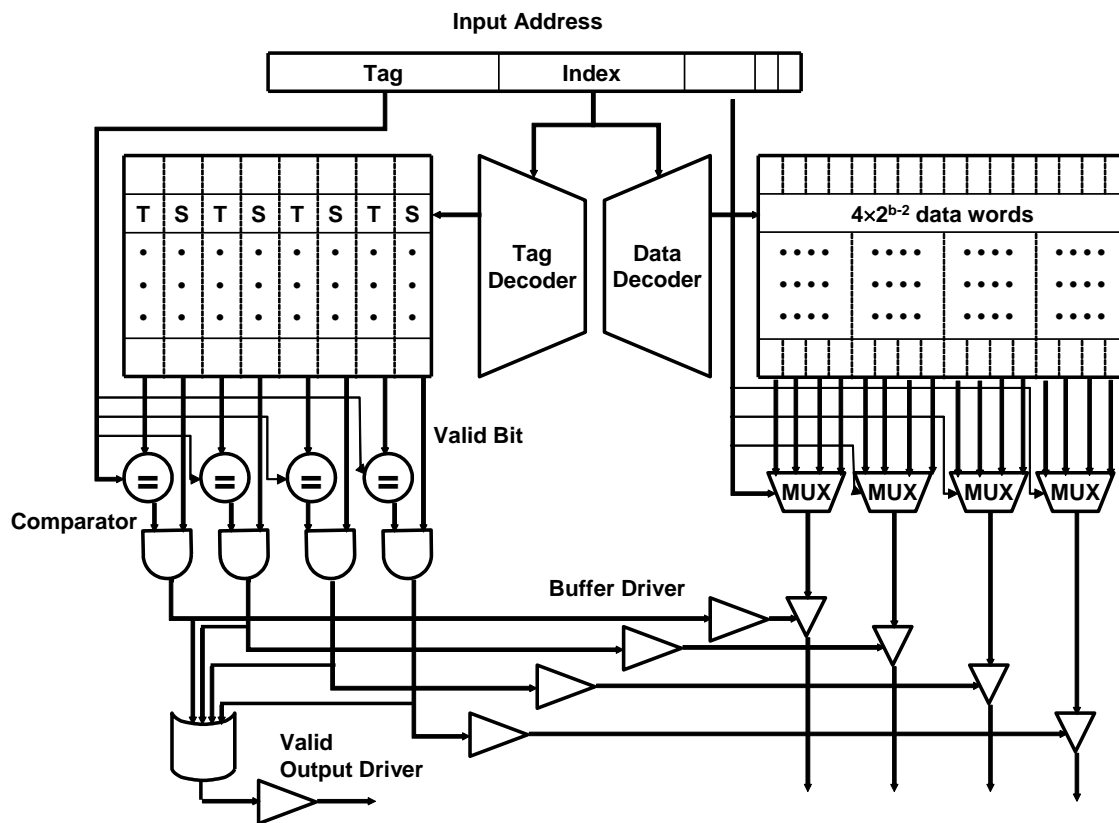

Problem M4.1.C

Miss-rate analysis

Now Ben is studying the effect of set-associativity on the cache performance. Since he now knows the access time of each configuration, he wants to know the miss-rate of each one. For the miss-rate analysis, Ben is considering two small caches: a direct-mapped cache with 8 lines with 16 bytes/line, and a 4-way set-associative cache of the same size. For the set-associative cache, Ben tries out two replacement policies – least recently used (LRU) and round robin (FIFO).

Ben tests the cache by accessing the following sequence of hexadecimal byte addresses, starting with empty caches. For simplicity, assume that the addresses are only 12 bits. Complete the following tables for the direct-mapped cache and both types of 4-way set-associative caches showing the progression of cache contents as accesses occur (in the tables, ‘inv’ = invalid, and the column of a particular cache line contains the {tag,index} contents of that line). *You only need to fill in elements in the table when a value changes.*

D-map	line in cache								hit?
	L0	L1	L2	L3	L4	L5	L6	L7	
110	inv	11	inv	inv	inv	inv	inv	inv	no
136				13					no
202	20								no
1A3									
102									
361									
204									
114									
1A4									
177									
301									
206									
135									

	D-map
Total Misses	
Total Accesses	

Address	4-way LRU								LRU	
	line in cache									hit?
	Set 0				Set 1					
	way0	way1	Way2	way3	way0	way1	way2	way3		
110	inv	Inv	Inv	inv	11	inv	inv	inv	no	
136					11	13			no	
202	20								no	
1A3										
102										
361										
204										
114										
1A4										
177										
301										
206										
135										

4-way LRU	
Total Misses	
Total Accesses	

Address	4-way FIFO								FIFO	
	line in cache									hit?
	Set 0				Set 1					
	way0	way1	way2	way3	way0	way1	way2	way3		
110	inv	Inv	Inv	inv	11	inv	inv	inv	no	
136						13			no	
202	20								no	
1A3										
102										
361										
204										
114										
1A4										
177										
301										
206										
135										

4-way FIFO	
Total Misses	
Total Accesses	

Problem M4.1.D**Average Latency**

Assume that the results of the above analysis can represent the average miss-rates of the direct-mapped and the 4-way LRU 128-KB caches studied in M4.1.A and M4.1.B. What would be the average memory access latency in CPU cycles for each cache (assume that a cache miss takes 20 cycles)? Which one is better? For the different replacement policies for the set-associative cache, which one has a smaller cache miss rate for the address stream in M4.1.C? Explain why. Is that replacement policy always going to yield better miss rates? If not, give a counter example using an address stream.

Problem M4.2: Pipelined Cache Access

This problem requires the knowledge of Lecture 6. Please, review it before answering the following questions. You may also want to take a look at pipeline lectures if you do not feel comfortable with the topic.

Problem M4.2.A

Ben Bitdiddle is designing a five-stage pipelined MIPS processor with separate 32 KB direct-mapped primary instruction and data caches. He runs simulations on his preliminary design, and he discovers that a cache access is on the critical path in his machine. After remembering that pipelining his processor helped to improve the machine's performance, he decides to try applying the same idea to caches. Ben breaks each cache access into three stages in order to reduce his cycle time. In the first stage the address is decoded. In the second stage the tag and data memory arrays are accessed; for cache reads, the data is available by the end of this stage. However, the tag still has to be checked—this is done in the third stage.

After pipelining the instruction and data caches, Ben's datapath design looks as follows:

I-Cache Address Decode	I-Cache Array Access	I-Cache Tag Check	Instruction Decode & Register Fetch	Execute	D-Cache Address Decode	D-Cache Array Access	D-Cache Tag Check	Write- back
------------------------------	----------------------------	-------------------------	--	---------	------------------------------	----------------------------	-------------------------	----------------

Alyssa P. Hacker examines Ben's design and points out that the third and fourth stages can be combined, so that the instruction cache tag check occurs in parallel with instruction decoding and register file read access. If Ben implements her suggestion, what must the processor do in the event of an instruction cache tag mismatch? Can Ben do the same thing with load instructions by combining the data cache tag check stage with the write-back stage? Why or why not?

Problem M4.2.B

Alyssa also notes that Ben's current design is flawed, as using three stages for a data cache access won't allow writes to memory to be handled correctly. She argues that Ben either needs to add a fourth stage or figure out another way to handle writes. What problem would be encountered on a data write? What can Ben do to keep a three-stage pipeline for the data cache?

Problem M4.2.C

With help from Alyssa, Ben streamlines his design to consist of eight stages (the handling of data writes is not shown):

I-Cache Address Decode	I-Cache Array Access	I-Cache Tag Check, Instruction Decode & Register Fetch	Execute	D-Cache Address Decode	D-Cache Array Access	D-Cache Tag Check	Write-Back
------------------------	----------------------	--	---------	------------------------	----------------------	-------------------	------------

Both the instruction and data caches are still direct-mapped. Would this scheme still work with a set-associative instruction cache? Why or why not? Would it work with a set-associative data cache? Why or why not?

Problem M4.2.D

After running additional simulations, Ben realizes that pipelining the caches was not entirely beneficial, as now the cache access latency has increased. If conditional branch instructions resolve in the Execute stage, how many cycles is the processor's branch delay?

Problem M4.2.E

Assume that Ben's datapath is fully-bypassed. When a load is executed, the data becomes available at the end of the D-cache Array Access stage. However, the tag has not yet been checked, so it is unknown whether the data is correct. If the load data is bypassed immediately, before the tag check occurs, then the instruction that depends on the load may execute with incorrect data. How can an interlock in the Instruction Decode stage solve this problem? How many cycles is the load delay using this scheme (assuming a cache hit)?

Problem M4.2.F

Alyssa proposes an alternative to using an interlock. She tells Ben to allow the load data to be bypassed from the end of the D-Cache Array Access stage, so that the dependent instruction can execute while the tag check is being performed. If there is a tag mismatch, the processor will wait for the correct data to be brought into the cache; then it will re-execute the load and all of the instructions behind it in the pipeline before continuing with the rest of the program. What processor state needs to be saved in order to implement this scheme? What additional steps need to be taken in the pipeline? Assume that a **DataReady** signal is asserted when the load data is available in the cache, and is set to 0 when the processor restarts its execution (you don't have to worry about the control logic details of this signal). How many cycles is the load delay using this scheme (assuming a cache hit)?

Problem M4.2.G

Ben is worried about the increased latency of the caches, particularly the data cache, so Alyssa suggests that he add a small, unpipelined cache in parallel with the D-cache. This “fast-path” cache can be considered as another level in the memory hierarchy, with the exception that it will be accessed simultaneously with the “slow-path” three-stage pipelined cache. Thus, the slow-path cache will contain a superset of the data found in the fast-path cache. A read hit in the fast-path cache will result in the requested data being available after one cycle. In this situation, the simultaneous read request to the slow-path cache will be ignored. A write hit in the fast-path cache will result in the data being written in one cycle. The simultaneous write to the slow-path cache will proceed as normal, so that the data will be written to both caches. If a read miss occurs in the fast-path cache, then the simultaneous read request to the slow-path cache will continue to be processed—if a read miss occurs in the slow-path cache, then the next level of the memory hierarchy will be accessed. The requested data will be placed in both the fast-path and slow-path caches. If a write miss occurs in the fast-path cache, then the simultaneous write to the slow-path cache will continue to be processed as normal. The fast-path cache uses a no-write allocate policy, meaning that on a write miss, the cache will remain unchanged—only the slow-path cache will be modified.

Ben’s new pipeline design looks as follows after implementing Alyssa’s suggestion:

I-Cache Address Decode	I-Cache Array Access	I-Cache Tag Check, Instruction Decode & Register Fetch	Execute	Fast-Path D-Cache Access and Tag Check & Slow Path D-Cache Address Decode	Slow-Path D-Cache Array Access	Slow-Path D-Cache Tag Check	Write-Back
------------------------	----------------------	--	---------	---	--------------------------------	-----------------------------	------------

The number of processor pipeline stages is still eight, even with the addition of the fast-path cache. Since the processor pipeline is still eight stages, what is the benefit of using a fast-path cache? Give an example of an instruction sequence and state how many cycles are saved if the fast-path cache always hits.

Problem M4.3: Victim Cache Evaluation

This problem requires the knowledge of Handout #5 (Victim Cache) and Lecture 6. Please, read these materials before answering the following questions.

Problem M4.3.A

Baseline Cache Design

The diagram below shows a 32-Byte fully associative cache with four 8-Byte cache lines. Each line consists of two 4-Byte words and has an associated tag and two status bits (valid and dirty). The Input Address is 32-bits and the two least significant bits are assumed to be zero. The output of the cache is a 32-bit word.

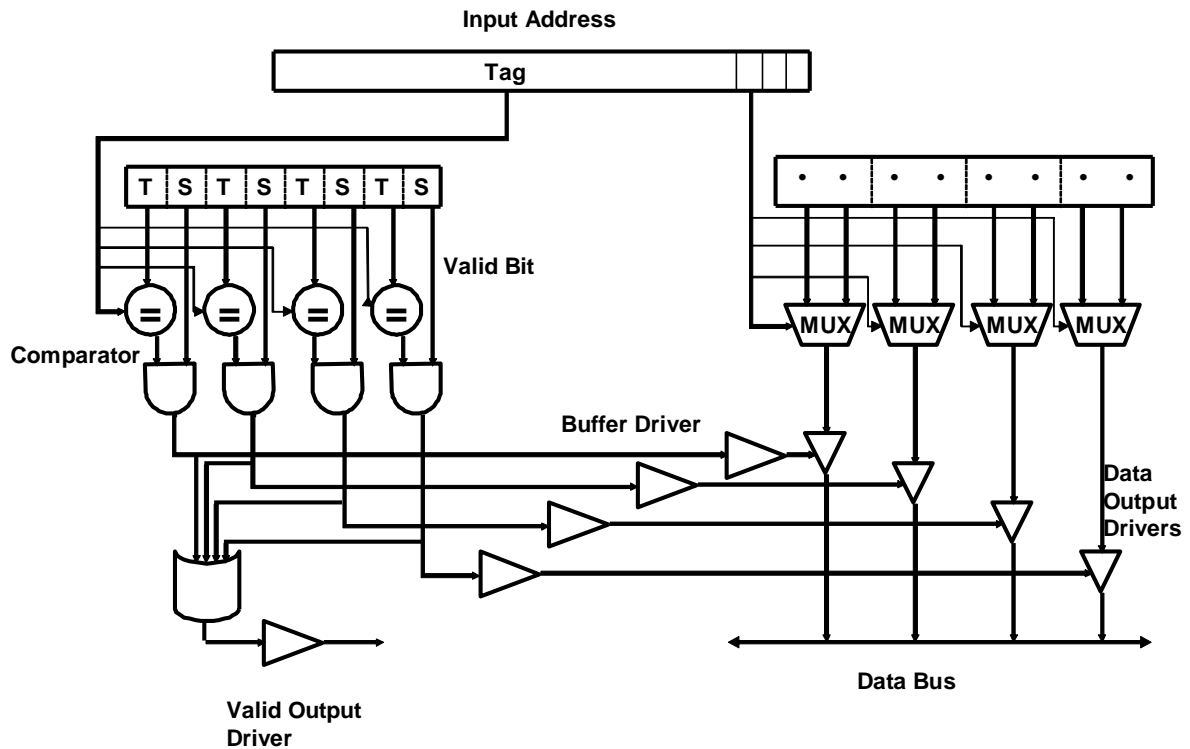

Please complete Table M4.3-1 below with delays across each element of the cache. Using the data you compute in Table M4.3-1, calculate the critical path delay through this cache (from when the Input Address is set to when both Valid Output Driver and the appropriate Data Output Driver are outputting valid data).

Component	Delay equation (ps)	FA (ps)
Comparator	$200 \times (\# \text{ of tag bits}) + 1000$	
N-to-1 MUX	$500 \times \log_2 N + 1000$	
Buffer driver	2000	
AND gate	1000	
OR gate	500	
Data output driver	$500 \times (\text{associativity}) + 1000$	
Valid output driver	1000	

Table M4.3-1

Critical Path Cache Delay: _____

Problem M4.3.B**Victim Cache Behavior**

Now we will study the impact of a victim cache on a cache hit rate. Our main L1 cache is a 128 byte, direct mapped cache with 16 bytes per cache line. The cache is word (4-bytes) addressable. The victim cache in Figure H5-A (in Handout #5) is a 32 byte fully associative cache with 16 bytes per cache line, and is also word-addressable. The victim cache uses the first in first out (FIFO) replacement policy.

Please complete Table M4.3-2 on the next page showing a trace of memory accesses. In the table, each entry contains the {tag,index} contents of that line, or “inv”, if no data is present. You should only fill in elements in the table when a value changes. For simplicity, the addresses are only 8 bits.

The first 3 lines of the table have been filled in for you.

For your convenience, the address breakdown for access to the main cache is depicted below.

7	6	4	3	2	1	0
TAG	INDEX		WORD SELECT		BYTE SELECT	

Problem M4.3.C**Average Memory Access Time**

Assume **15%** of memory accesses are resolved in the victim cache. If retrieving data from the victim cache takes **5 cycles** and retrieving data from main memory takes **55 cycles**, by how many cycles does the victim cache improve the average memory access time?

Input Address	Main Cache									Victim Cache		
	L0	L1	L2	L3	L4	L5	L6	L7	Hit?	Way0	Way1	Hit?
	inv	inv	inv	inv	inv	inv	inv	inv	-	inv	inv	-
00	0								N			N
80	8								N	0		N
04	0								N	8		Y
A0												
10												
C0												
18												
20												
8C												
28												
AC												
38												
C4												
3C												
48												
0C												
24												

Table M4.3-2

Problem M4.4: Loop Ordering

This problem requires the knowledge of Lecture 6. Please, read it before answering the following questions.

This problem evaluates the cache performances for different loop orderings. You are asked to consider the following two loops, written in C, which calculate the sum of the entries in a 128 by 64 matrix of 32-bit integers:

Loop A	Loop B
<pre>sum = 0; for (i = 0; i < 128; i++) for (j = 0; j < 64; j++) sum += A[i][j];</pre>	<pre>sum = 0; for (j = 0; j < 64; j++) for (i = 0; i < 128; i++) sum += A[i][j];</pre>

The matrix A is stored contiguously in memory in row-major order. Row major order means that elements in the same row of the matrix are adjacent in memory as shown in the following memory layout:

$A[i][j]$ resides in memory location $[4 * (64 * i + j)]$

Memory Location:

0	4		252	256		$4 * (64 * 127 + 63)$
A[0][0]	A[0][1]	...	A[0][63]	A[1][0]	...	A[127][63]

For *Problem M4.4.A* to *Problem M4.4.C*, assume that the caches are initially empty. Also, assume that only accesses to matrix A cause memory references and all other necessary variables are stored in registers. Instructions are in a separate instruction cache.

Problem M4.4.A

Consider a 4KB direct-mapped data cache with 8-word (32-byte) cache lines. Calculate the number of cache misses that will occur when running Loop A. Calculate the number of cache misses that will occur when running Loop B.

The number of cache misses for Loop A: _____

The number of cache misses for Loop B: _____

Problem M4.4.B

Consider a direct-mapped data cache with 8-word (32-byte) cache lines. Calculate the minimum number of cache lines required for the data cache if Loop A is to run without any cache misses other than compulsory misses. Calculate the minimum number of cache lines required for the data cache if Loop B is to run without any cache misses other than compulsory misses.

Data-cache size required for Loop A: _____ cache line(s)

Data-cache size required for Loop B: _____ cache line(s)

Problem M4.4.C

Consider a 4KB fully-associative data cache with 8-word (32-byte) cache lines. This data cache uses a first-in/first-out (FIFO) replacement policy. Calculate the number of cache misses that will occur when running Loop A. Calculate the number of cache misses that will occur when running Loop B.

The number of cache misses for Loop A: _____

The number of cache misses for Loop B: _____

Problem M4.5: Cache Parameters

For each of the following statements about making a change to a cache design, circle **True** or **False** and provide a one sentence explanation of your choice. Assume all cache parameters (capacity, associativity, line size) remain fixed except for the single change described in each question. Please provide a one sentence explanation of your answer.

Problem M4.5.A

Doubling the line size halves the number of tags in the cache

True / False

Problem M4.5.B

Doubling the associativity doubles the number of tags in the cache.

True / False

Problem M4.5.C

Doubling cache capacity of a direct-mapped cache usually reduces conflict misses.

True / False

Problem M4.5.D

Doubling cache capacity of a direct-mapped cache usually reduces compulsory misses.

True / False

Problem M4.5.E

Doubling the line size usually reduces compulsory misses.

True / False

Problem M4.6: Microtags

Problem M4.6.A

Explain in one or two sentences why direct-mapped caches have much lower hit latency (as measured in picoseconds) than set-associative caches of the same capacity.

Problem M4.6.B

A 32-bit byte-addressed machine has an 8KB, 4-way set-associative data cache with 32-byte lines. The following figure shows how the address is divided into tag, index and offset fields. Give the number of bits in each field.

tag	Index	offset
-----	-------	--------

of bits in the tag: _____

of bits in the index: _____

of bits in the offset: _____

Microtags (for questions M4.6.C – M4.6.H)

Several commercial processors (including the UltraSPARC-III and the Pentium-4) reduce the hit latency of a set-associative cache by using only a subset of the tag bits (a “microtag”) to select the matching way before speculatively forwarding data to the CPU. The remaining tag bits are checked in a subsequent clock cycle to determine if the access was actually a hit. The figure below illustrates the structure of a cache using this scheme.

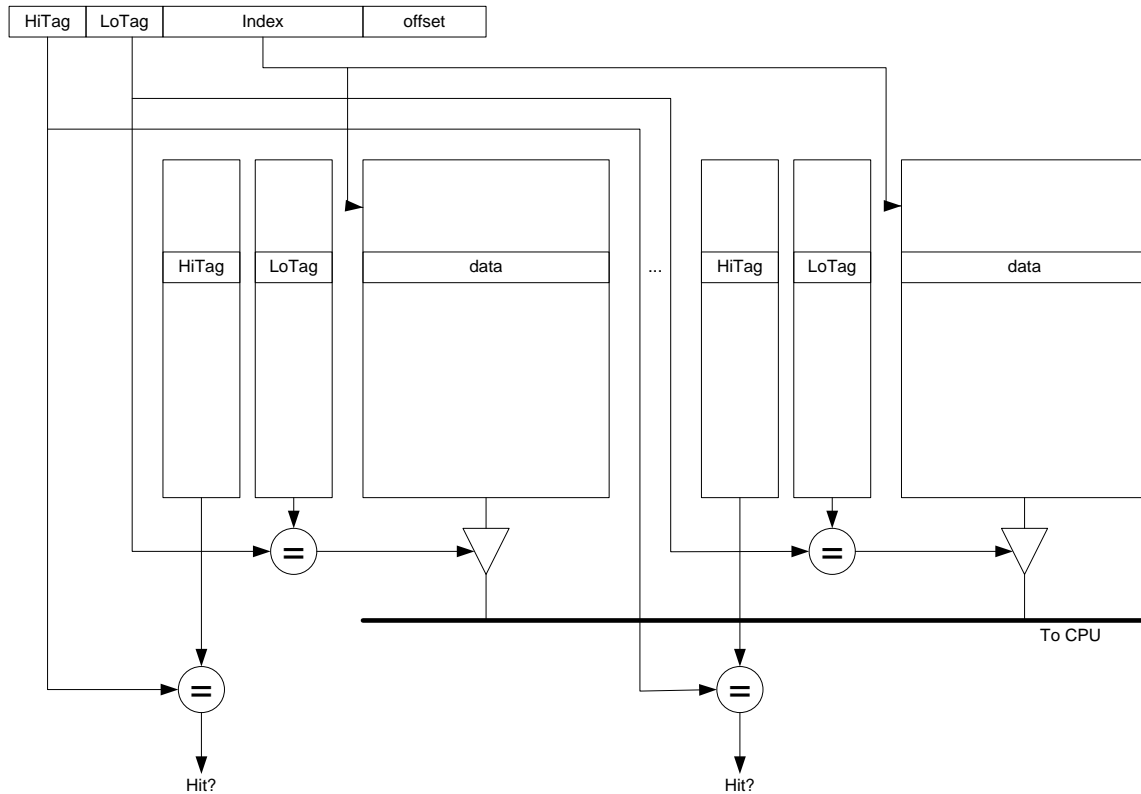

Problem M4.6.C

The tag field is sub-divided into a **loTag** field used to select a way and a **hiTag** field used for subsequent hit/miss checks, as shown below.

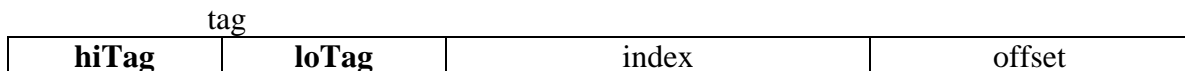

The cache design requires that all lines within a set have unique loTag fields. In one or two sentences, explain why this is necessary.

Problem M4.6.D

If the **loTag** field is exactly two bits long, will the cache have greater, fewer, or an equal number of conflict misses as a direct-mapped cache of the same capacity? State any assumptions made about replacement policy.

Problem M4.6.E

If the **loTag** field is greater than two bits long, are there any additional constraints on replacement policy beyond those in a conventional 4-way set-associative cache?

Problem M4.6.F

Does this scheme reduce the time required to complete a write to the cache? Explain in one or two sentences.

Problem M4.6.G

In practice, microtags hold virtual address bits to remove address translation from the critical path, while the full tag check is performed on translated physical addresses. If the **loTag** bits can only hold untranslated bits of the virtual address, what is the largest number of **loTag** bits possible if the machine has a 16KB virtual memory page size? (Assume 8KB 4-way set-associative cache as in Question M4.6.B)

Problem M4.6.H

Describe how microtags can be made much larger, to also include virtual address bits subject to address translation. Your design should not require address translation before speculatively forwarding data to the CPU. Your explanation should describe the replacement policy and any additional state the machine must maintain.

Problem M4.7: Write Buffer for Data Cache (2005 Fall Part C)

In order to boost the performance of memory writes, Ben Bitdiddle has proposed to add a write buffer to our 5-stage fully-bypassed MIPS pipeline as shown below. Assuming a write-through/write no-allocate cache, every memory write request will be queued in the write buffer in the MEM stage, and the pipeline will continue execution without waiting for writes to be completed. A queued entry in the write buffer gets cleared only after the write operation completes, so the maximum number of outstanding memory writes is limited by the size of the write buffer.

Please answer the following questions.

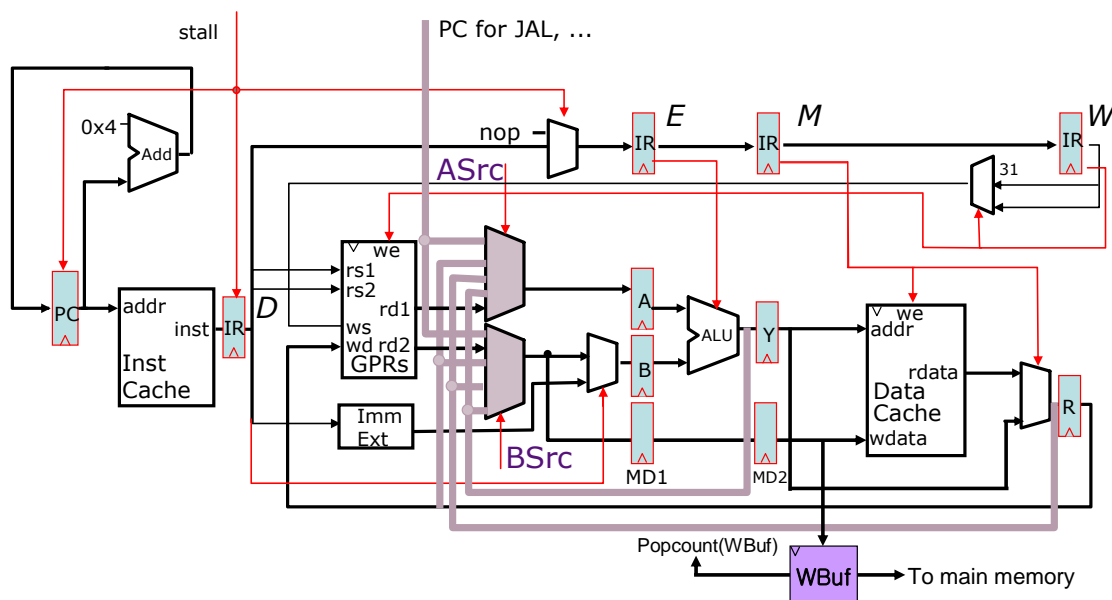

Problem M4.7.A

Ben wants to determine the size of the write buffer, so he runs benchmark X to get the observation below. What will be the average number of writes in flight (=the number of valid entries in the write buffer on average)?

- 1) The CPI of the benchmark is 2.
- 2) On average, one of every 20 instructions is a memory write.
- 3) Memory has a latency of 100 cycles, and is fully pipelined.

Problem M4.7.B

Based on the experiment in the previous question, Ben has added the write buffer with N entries to the pipeline. (Do not use your answer in Question 7 to replace N .) Now he wants to design a stall logic to prevent a write buffer overflow. The structure of the write buffer is shown in the figure below. $\text{Popcount}(\text{WBuf})$ gives the number of valid entries in the write buffer at any given moment.

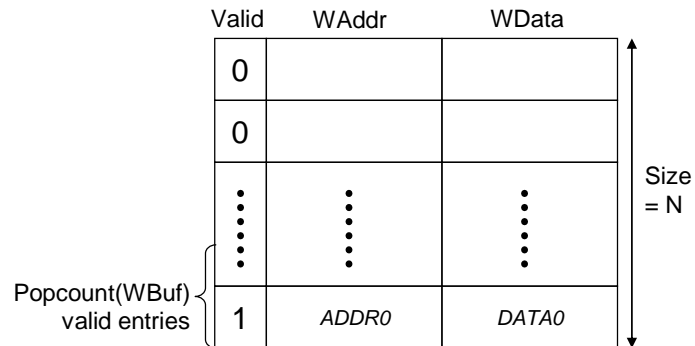

Please write down the stall condition to prevent write buffer overflows. You should derive the condition without assuming any modification of the given pipeline. You can use Boolean and arithmetic operations in your stall condition.

Stall =

Problem M4.7.C

In order to optimize the stall logic, Ben has decided to add a predecode bit to detect store instructions in the instruction cache (I-Cache). That is, now every entry in the I-Cache has a store bit associated with it, and it propagates through the pipeline with an S_{stage} bit added to each pipeline register (except the one between MEM and WB stages) as shown below. $\text{Popcount}(\text{Pipeline})$ gives the number of store instructions that are in flight (= number of S_{stage} bits set to 1).

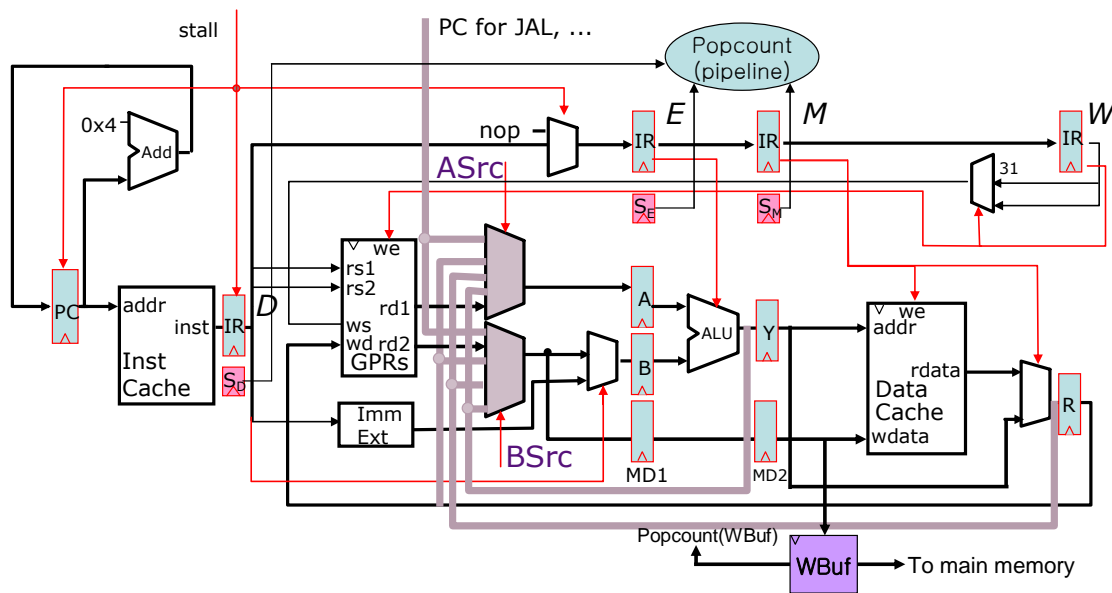

How will this optimization change the stall condition, if at all?

Stall =

Problem M5.1: Virtual Memory Bits

This problem requires the knowledge of Handout #6 (Virtual Memory Implementation) and Lecture 7 and 8. Please, read these materials before answering the following questions.

In this problem we consider simple virtual memory enhancements.

Problem M5.1.A

Whenever a TLB entry is replaced we write the entire entry back to the page table. Ben thinks this is a waste of memory bandwidth. He thinks only a few of the bits need to be written back. For each of the bits explain why or why not they need to be written back to the page table.

With this in mind, we will see how we can minimize the number of bits we actually need in each TLB entry throughout the rest of the problem.

Problem M5.1.B

Ben does not like the TLB design. He thinks the TLB Entry Valid bit should be dropped and the kernel software should be changed to ensure that all TLB entries are always valid. Is this a good idea? Explain the advantages and disadvantages of such a design.

Problem M5.1.C

Alyssa got wind of Ben's idea and suggests a different scheme to eliminate one of the valid bits. She thinks the page table entry valid and TLB Entry Valid bits can be combined into a single bit.

On a refill this combined valid bit will take the value that the page table entry valid bit had. A TLB entry is invalidated by writing it back to the page table and setting the combined valid bit in the TLB entry to invalid.

How does the kernel software need to change to make such a scheme work? How do the exceptions that the TLB produces change?

Problem M5.1.D

Now, Bud Jet jumps into the game. He wants to keep the TLB Entry Valid bit. However, there is no way he is going to have two valid bits in each TLB entry (one for the TLB entry one for the page table entry). Thus, he decides to drop the page table entry valid bit from the TLB entry.

How does the kernel software need to change to make this work well? How do the exceptions that the TLB produces change?

Problem M5.1.E

Compare your answers to Problem M5.1.C and M5.1.D. What scheme will lead to better performance?

Problem M5.1.F

How about the R bit? Can we remove them from the TLB entry without significantly impacting performance? Explain briefly.

Problem M5.1.G

The processor has a kernel (supervisor) mode bit. Whenever kernel software executes the bit is set. When user code executes the bit is not set. Parts of the user's virtual address space are only accessible to the kernel. The supervisor bit in the page table is used to protect this region—an exception is raised if the user tries to access a page that has the supervisor bit set.

Bud Jet is on a roll and he decides to eliminate the supervisor bit from each TLB entry. Explain how the kernel software needs to change so that we still have the protection mechanism and the kernel can still access these pages through the virtual memory system.

Problem M5.1.H

Alyssa P. Hacker thinks Ben and Bud are being a little picky about these bits, but has devised a scheme where the TLB entry does not need the M bit or the U bit. It works as follows. If a TLB miss occurs due to a load, then the page table entry is read from memory and placed in the TLB. However, in this case the W bit will always be set to 0. Provide the details of how the rest of the scheme works (what happens during a store, when do the entries need to be written back to memory, when are the U and M bits modified in the page table, etc.).

Problem M5.2: Page Size and TLBs (2005 Fall Part D)

This problem requires the knowledge of Handout #6 (Virtual Memory Implementation) and Lecture 8. Please, read these materials before answering the following questions.

Assume that we use a hierarchical page table described in Handout #6.

The processor has a data TLB with 64 entries, and each entry can map either a 4KB page or a 4MB page. After a TLB miss, a hardware engine walks the page table to reload the TLB. The TLB uses a first-in/first-out (FIFO) replacement policy.

We will evaluate the memory usage and execution of the following program which adds the elements from two 1MB arrays and stores the results in a third 1MB array (note that, 1MB = 1,048,576 Bytes):

```
byte A[1048576]; // 1MB array
byte B[1048576]; // 1MB array
byte C[1048576]; // 1MB array

for(int i=0; i<1048576; i++)
    C[i] = A[i] + B[i];
```

We assume the A, B, and C arrays are allocated in a contiguous 3MB region of physical memory. **We will consider two possible virtual memory mappings:**

- **4KB:** the arrays are mapped using 768 4KB pages (each array uses 256 pages).
- **4MB:** the arrays are mapped using a single 4MB page.

For the following questions, assume that the above program is the only process in the system, and ignore any instruction memory or operating system overheads. Assume that the arrays are aligned in memory to minimize the number of page table entries needed.

Problem M5.2.A

This is the breakdown of a virtual address which maps to a 4KB page:

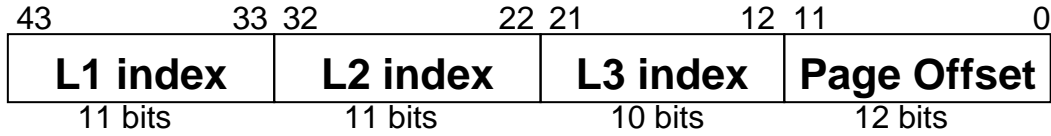

Show the corresponding breakdown of a virtual address which maps to a 4MB page. Include the field names and bit ranges in your answer.

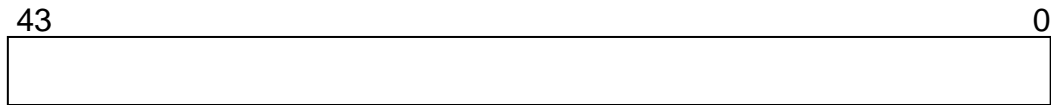

Problem M5.2.B

Page Table Overhead

We define page table overhead (PTO) as:

PTO =	Physical memory that is allocated to page tables
	Physical memory that is allocated to data pages

For the given program, what is the PTO for each of the two mappings?

PTO_{4KB} =	
----------------------------	--

PTO_{4MB} =	
----------------------------	--

Problem M5.2.C**Page Fragmentation Overhead**

We define page fragmentation overhead (PFO) as:

PFO =	Physical memory that is allocated to data pages but is never accessed
	Physical memory that is allocated to data pages and is accessed

For the given program, what is the PFO for each of the two mappings?

PFO_{4KB} =	

PFO_{4MB} =	

Problem M5.2.D

Consider the execution of the given program, assuming that the data TLB is initially empty. For each of the two mappings, how many TLB misses occur, and how many page table memory references are required per miss to reload the TLB?

	Data TLB misses	Page table memory references (per miss)
4KB:		
4MB:		

Problem M5.2.E

Which of the following is the best estimate for how much longer the program takes to execute with the 4KB page mapping compared to the 4MB page mapping? Circle one choice and **briefly explain** your answer (about one sentence).

1.01×	10×	1,000×	1,000,000×
--------------	------------	---------------	-------------------

Problem M5.3: Page Size and TLBs

This problem requires the knowledge of Handout #6 (Virtual Memory Implementation) and Lecture 8. Please, read these materials before answering the following questions.

The configuration of the hierarchical page table in this problem is similar to the one in Handout #6, but we modify two parameters: 1) this problem evaluates a virtual memory system with two page sizes, 4KB and 1MB (instead of 4 MB), and 2) all PTEs are 16 Bytes (instead of 8 Bytes). The following figure summarizes the page table structure and indicates the sizes of the page tables and data pages (not drawn to scale):

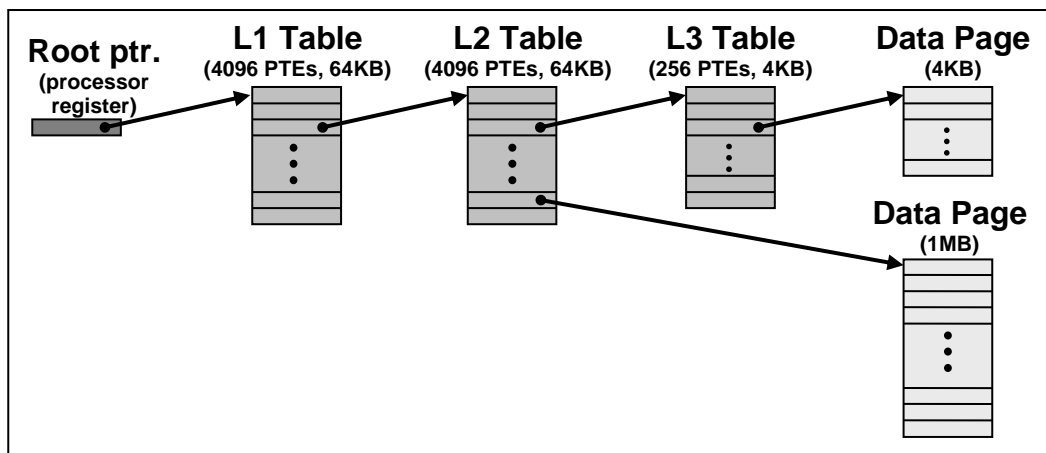

The processor has a data TLB with 64 entries, and each entry can map either a 4KB page or a 1MB page. After a TLB miss, a hardware engine walks the page table to reload the TLB. The TLB uses a first-in/first-out (FIFO) replacement policy.

We will evaluate the execution of the following program which adds the elements from two 1MB arrays and stores the results in a third 1MB array (note that, 1MB = 1,048,576 Bytes, the starting address of the arrays are given below):

```
byte A[1048576]; // 1MB array 0x00001000000
byte B[1048576]; // 1MB array 0x00001100000
byte C[1048576]; // 1MB array 0x00001200000

for(int i=0; i<1048576; i++)
    C[i] = A[i] + B[i];
```

Assume that the above program is the only process in the system, and ignore any instruction memory or operating system overheads. The data TLB is initially empty.

Problem M5.3.A

Consider the execution of the program. There is no cache and each memory lookup has 100 cycle latency.

If all data pages are 4KB, compute the ratio of cycles for address translation to cycles for data access.

If all data pages are 1MB, compute the ratio of cycles for address translation to cycles for data access.

Problem M5.3.B

For this question, assume that in addition, we have a PTE cache with one cycle latency. A PTE cache contains page table entries. If this PTE cache has unlimited capacity, compute the ratio of cycles for address translation to cycles for data access for the 4KB data page case.

Problem M5.3.C

With the use of a PTE cache, is there any benefit to caching L3 PTE entries? Explain.

Problem M5.3.D

What is the minimum capacity (number of entries) needed in the PTE cache to get the same performance as an unlimited PTE cache? (Assume that the PTE cache does not cache L3 PTE entries and all data pages are 4KB)

Problem M5.3.E

Instead of a PTE cache, we allow the data cache to cache data as well as PTEs. The data cache is a 4KB direct-mapped with 16 byte lines. Compute the ratio of cycles for address translation to cycles for data access for the 4KB data page case.

Problem M5.4: 64-bit Virtual Memory

This problem examines page tables in the context of processors with 64-bit addressing.

Problem M5.4.A

Single level page tables

For a computer with 64-bit virtual addresses, how large is the page table if only a single-level page table is used? Assume that each page is 4KB, that each page table entry is 8 bytes, and that the processor is byte-addressable.

Problem M5.4.B

Let's be practical

Many current implementations of 64-bit ISAs implement only part of the large virtual address space. One way to do this is to segment the virtual address space into three parts as shown below: one used for stack, one used for code and heap data, and the third one unused.

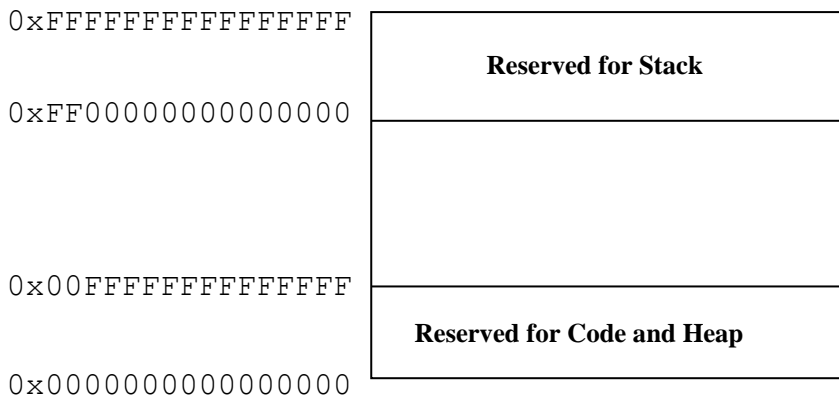

A special circuit is used to detect whether the top eight bits of an address are all zeros or all ones before the address is sent to the virtual memory system. If they are not all equal, an invalid virtual memory address trap is raised. This scheme in effect removes the top seven bits from the virtual memory address, but retains a memory layout that will be compatible with future designs that implement a larger virtual address space.

The MIPS R10000 does something similar. Because a 64-bit address is unnecessarily large, only the low 44 address bits are translated. This also reduces the cost of TLB and cache tag arrays. The high two virtual address bits (bits 63:62) select between user, supervisor, and kernel address spaces. The intermediate address bits (61:44) must either be all zeros or all ones, depending on the address region.

How large is a single-level page table that would support MIPS R10000 addresses? Assume that each page is 4KB, that each page table entry is 8 bytes, and that the processor is byte-addressable.

Problem M5.4.C**Page table overhead**

A three-level hierarchical page table can be used to reduce the page table size. Suppose we break up the 44-bit virtual address (VA) as follows:

VA[43:33]	VA[32:22]	VA[21:12]	VA[11:0]
1 st level index	2 nd level index	3 rd level index	Page offset

If page table overhead is defined as (in bytes):

$$\frac{\text{PHYSICAL MEMORY USED BY PAGE TABLES FOR A USER PROCESS}}{\text{PHYSICAL MEMORY USED BY THE USER CODE, HEAP, AND STACK}}$$

Remember that a complete page table page (1024 or 2048 PTEs) is allocated even if only one PTE is used. Assume a large enough physical memory that no pages are ever swapped to disk. Use 64-bit PTEs. What is the smallest possible page table overhead for the three-level hierarchical scheme?

Assume that once a user page is allocated in memory, the whole page is considered to be useful. What is the largest possible page table overhead for the three-level hierarchical scheme?

Problem M5.4.D**PTE Overhead**

The MIPS R10000 uses a 40 bit physical address. The physical translation section of the TLB contains the physical page number (also known as PPN), one “valid,” one “dirty,” and three “cache status” bits.

What is the minimum size of a PTE assuming all pages are 4KB?

MIPS/Linux stores each PTE in a 64 bit word. How many bits are wasted if it uses the minimum size you have just calculated?

Problem M5.4.E**Page table implementation**

The following comment is from the source code of MIPS/Linux and, despite its cryptic terminology, describes a three-level page table.

```

/*
 * Each address space has 2 4K pages as its page directory, giving 1024
 * 8 byte pointers to pmd tables. Each pmd table is a pair of 4K pages,
 *
 * giving 1024 8 byte pointers to page tables. Each (3rd level) page
 *
 * table is a single 4K page, giving 512 8 byte ptes.
 *
 * /

```

Assuming 4K pages, how long is each index?

Index	Length (bits)
Top-level (“page directory”)	
2 nd -level	
3 rd -level	

Problem M5.4.F**Variable Page Sizes**

A TLB may have a *page mask* field that allows an entry to map a page size of any power of four between 4KB and 16MB. The page mask specifies which bits of the virtual address represent the page offset (and should therefore not be included in translation). What are the maximum and minimum reach of a 64-entry TLB using such a mask? The R10000 actually doubles this reach with little overhead by having each TLB entry map *two* physical pages, but don’t worry about that here.

Problem M5.4.G**Virtual Memory and Caches**

Ben Bitdiddle is designing a 4-way set associative cache that is virtually indexed and virtually tagged. He realizes that such a cache suffers from a *homonym* aliasing problem. The *homonym* problem happens when two processes use the same virtual address to access different physical locations. Ben asks Alyssa P. Hacker for help with solving this problem. She suggests that Ben should add a PID (Process ID) to the virtual tag. Does this solve the *homonym* problem?

Another problem with virtually indexed and virtually tagged caches is called *synonym* problem. *Synonym* problem happens when distinct virtual addresses refer to the same physical location. Does Alyssa’s idea solve this problem?

Ben thinks that a different way of solving *synonym* and *homonym* problems is to have a direct mapped cache, rather than a set associative cache. Is he right?

Problem M5.6: Cache Basics (2005 Fall Part A)

Questions in Part A are about the operations of virtual and physical address caches in two different configurations: direct-mapped and 2-way set-associative. The direct-mapped cache has 8 cache lines with 8 bytes/line (i.e. the total size is 64 bytes), and the 2-way set-associative cache is the same size (i.e. 32 bytes/way) with the same cache line size. The page size is 16 bytes.

Please answer the following questions.

Problem M5.6.A

For each cache configuration shown in the figure below, which block(s) can virtual address 0x34 be mapped to? Fill out the table at the bottom of this page. (Consider both virtually indexed and physically indexed cases for each configuration, and enumerate **all** possible blocks.)

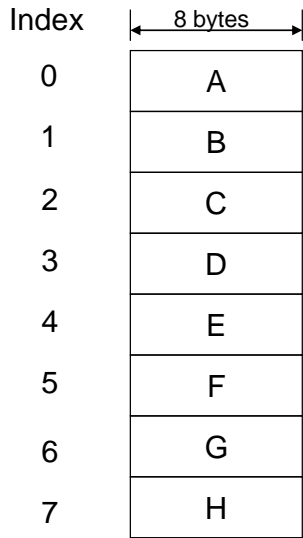

(A) Direct-mapped Cache

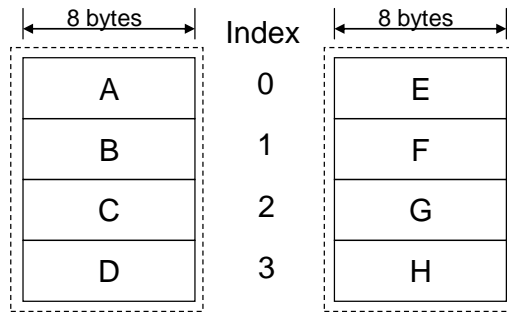

(B) 2-way Set-associative Cache

	Virtually indexed	Physically indexed
Direct-mapped (A)		
2-way Set-associative (B)		

Problem M5.6.B

We ask you to follow step-by-step operations of the virtually indexed, physically tagged, 2-way set-associative cache shown in the previous question (Figure B). You are given a snapshot of the cache and TLB states in the figure below. Assume that the smallest physical tags (i.e. no index part contained) are taken from the high order bits of an address, and that Least Recently Used (LRU) replacement policy is used. (Only valid (V) bits and tags are shown for the cache; VPNs and PPNs for the TLB.)

Index	V	Tags (way0)	V	Tags (way1)
0	1	0x45	0	
1	1	0x3D	0	
2	1	0x1D	0	
3	0		0	

Initial cache tag states

VPN	PPN	VPN	PPN
0x0	0x0A	0x10	0x6A
0x1	0x1A	0x20	0x7A
0x2	0x2A	0x30	0x8A
0x3	0x3A	0x40	0x9A
0x5	0x4A	0x50	0xAA
0x7	0x5A	0x70	0xBA

TLB states

After accessing the address sequence (all in virtual address) given below, what will be the final cache states? Please fill out the table at the bottom of this page with the new cache states. You can write tags either in binary or in hexadecimal form.

Address sequence: 0x34 -> 0x38 -> 0x50 -> 0x54 -> 0x208 -> 0x20C -> 0x74 -> 0x54

Index	V	Tags (way0)	V	Tags (way1)
0				
1				
2				
3				

Final cache tag states

Problem M5.6.C

Assume that a cache hit takes one cycle and that a cache miss takes 16 cycles. What is the average memory access time for the address sequence of 8 words given in Question 5.6.B?

Problem M5.7: Handling TLB Misses (2005 Fall Part B)

In the following questions, we ask you about the procedure of handling TLB misses. The following figure shows the setup for this part and each component's initial states.

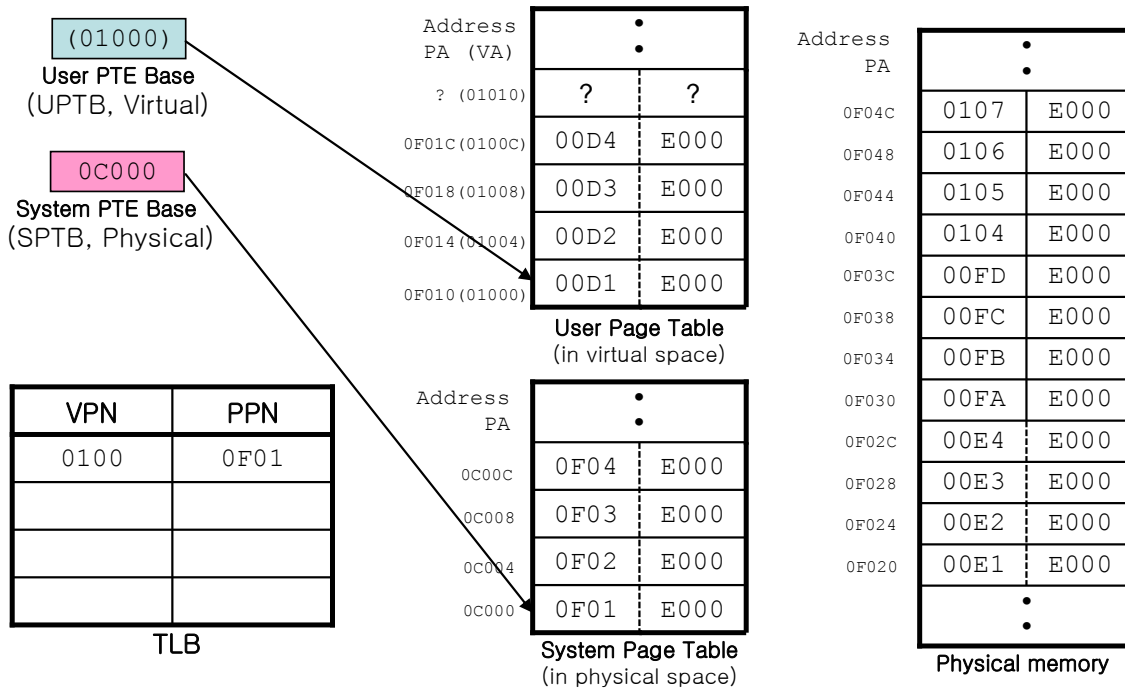

- Notes**
1. All numbers are in hexadecimal.
 2. Virtual addresses are shown in parentheses, and physical addresses without parentheses.

For the rest of this part, we assume the following:

- 1) The system uses 20-bit virtual addresses and 20-bit physical addresses.
- 2) The page size is 16 bytes.
- 3) We use a linear (not hierarchical) page table with 4-byte page table entry (PTE). A PTE can be broken down into the following fields. (Don't worry about the status bits, PTE[15:0], for the rest of Part B.)

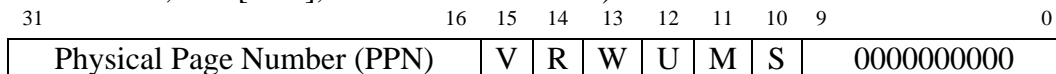

- 4) The TLB contains 4 entries and is fully associative.

On the next page, we show a pseudo code for the TLB refill algorithm.

```

// On a TLB miss, "MA" (Miss Address) contains the address of that
// miss. Note that MA is a virtual address.

// UTOP is the top of user virtual memory in the virtual address
// space. The user page table is mapped to this address and up.
#define UTOP 0x01000

// UPTB and SPTB stand for User PTE Base and System PTE Base,
// respectively. See the figure in the previous page.

if (MA < UTOP) {
    // This TLB miss was caused by a normal user-level memory access

    // Note that another TLB miss can occur here while loading a PTE.
    LW Rtemp, UPTB+4*(MA>>4); // load a PTE using a virtual address
}
else {
    // This TLB miss occurred while accessing system pages (e.g. page
    // tables)

    // TLB miss cannot happen here because we use a physical address.
    LW_physical Rtemp, SPTB+4*((MA-UTOP)>>4); // load a PTE using a
                                                // physical address
}

(Protection check on Rtemp); // Don't worry about this step here
(Extract PPN from Rtemp and store it to the TLB with VPN);
(Restart the instruction that caused the TLB miss);

```

TLB refill algorithm

Problem M5.7.A

What will be the physical address corresponding to the virtual address 0x00030? Fill out the TLB states below after an access to the address 0x00030 is completed.

Virtual address 0x00030 -> Physical address (0x _____)

VPN	PPN
0x0100	0x0F01

TLB states

Problem M5.7.B

What will be the physical address corresponding to the virtual address 0x00050? Fill out the TLB states below after an access to the address 0x00050 is completed. (Start over from the initial system states, not from your system states after solving the previous question.)

Virtual address 0x00050 -> Physical address (0x _____)

VPN	PPN
0x0100	0x0F01

TLB states

Problem M5.7.C

We integrate virtual memory support into our baseline 5-stage MIPS pipeline using the TLB miss handler. We assume that accessing the TLB does not incur an extra cycle in memory access in case of hits.

Without virtual memory support (i.e. we had only a single address space for the entire system), the average cycles per instruction (CPI) was 2 to run Program X. If the TLB misses 10 times for instructions and 20 times for data in every 1,000 instructions on average, and it takes 20 cycles to handle a TLB miss, what will be the new CPI (approximately)?

Problem M5.8: Cache Basics (Fall 2010 Part A)

Problem M5.8.A

Suppose we have a **virtually-indexed, physically-tagged** 2-way set associative cache. Each way has 8 cache blocks (i.e., there are 8 sets) and the block size is 8 bytes. The page size is 256 bytes, and the byte-addressed machine uses 16-bit virtual address and 16-bit physical address. Do not worry about aliasing problems for this question.

The next diagram shows the corresponding breakdown of a virtual address and a physical address in this system (index, tag, and byte offset). Replace “A”, “B”, “C” and “D” with bit indexes showing the size of each field. Note that tags should contain the minimum number of bits required to provide the information needed to check whether the cache hits.

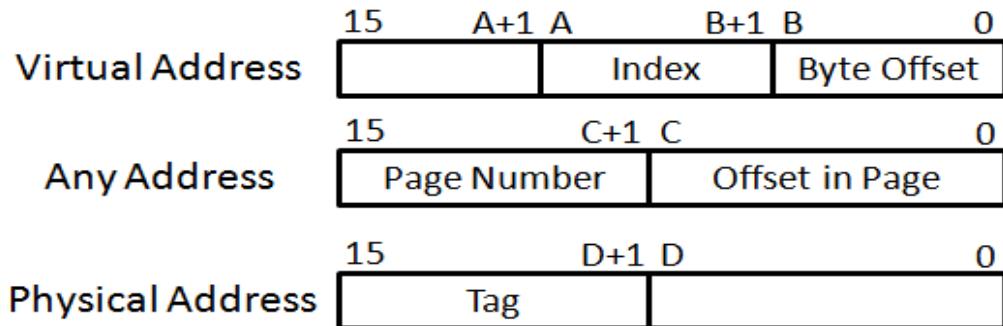

A: _____ B: _____ C: _____ D: _____

Problem M5.8.B

Now, we test the cache by accessing the following **virtual address**. We provide the corresponding binary number for the virtual address.

0x0151 (0000000101010001)

The table below shows the current TLB states. After each address is accessed, complete tables on the next page and show the progression of cache states (in the tables, inv = invalid, and the column shows tags). Assume that the **Least Recently Used (LRU)** replacement policy is used. “**LRU way**” bit in the cache represents the way that is least recently used. (Note that this bit should also be updated if necessary.) *You may only fill in the elements in the table when a value changes from the previous table. Write tags in hexadecimal numbers. If the memory access is a cache hit, mark with “V” where the hit occurred.* Note that the cache uses **physical tags**.

VPN	PPN
0x00	0x0A
0x01	0x1A
0x02	0x2A
0x03	0x3A

0. Initial State			
idx	LRU Way?	Tags (Way 0)	Tags (Way 1)
0	0	inv	0x40
1	0	inv	inv
2	0	0x8B	0x14
3	0	inv	inv
4	0	inv	inv
5	1	0x3F	0xAA
6	0	inv	inv
7	1	0xC3	0x1F

1. State after access 0x0151			
idx	LRU Way?	Tags (Way 0)	Tags (Way 1)
0			
1			
2			
3			
4			
5			
6			
7			

Problem M5.8.C

Suppose we have a 2-way set-associative cache. Each way has 8 cache blocks (i.e., there are 8 sets) and the block size is 8 bytes/block, so the total is 128 bytes. The following figure shows each cache block in this cache configuration.

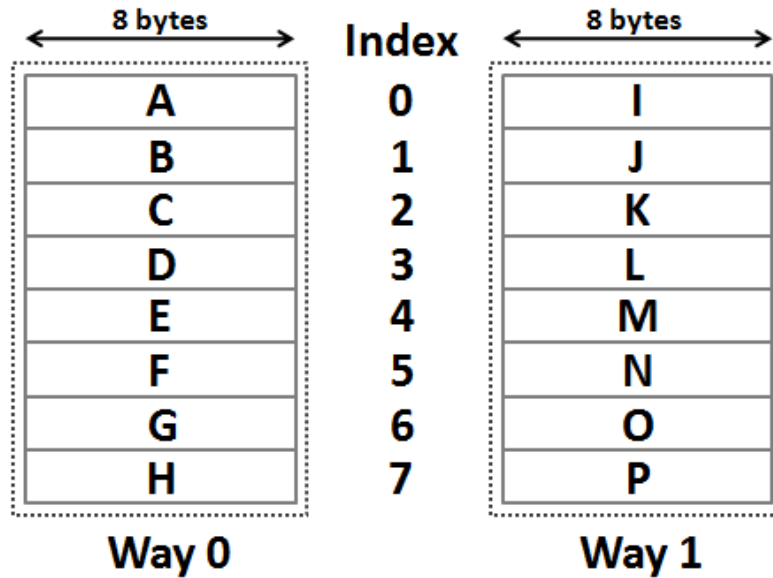

Cache Configuration

Suppose this cache is **virtually indexed**. A program wants to read from a **virtual address** 0x6E, and the physical address of this virtual address 0x6E is unknown (could be arbitrary). Enumerate **all** blocks (A,B,C,D,...) that can possibly hold the content of the virtual address 0x6E, for each given page size in the next table.

Page Size	Block(s) which can be mapped to
16 bytes	
32 bytes	
64 bytes	

Problem M5.8.D

Now, suppose the cache is **physically indexed**. A program wants to read from the same **virtual address** 0x6E, and the physical address of this virtual address 0x6E is unknown (could be arbitrary). Enumerate **all** blocks (A,B,C,D,...) that can possibly hold the content of the virtual address 0x6E, for each given page size in the next table.

Page Size	Block(s) which can be mapped to
16 bytes	
32 bytes	
64 bytes	

Problem M5.9: Hierarchical Page Table & TLB (Fall 2010 Part B)

Suppose there is a virtual memory system with 64KB page which has 2-level hierarchical page table. The **physical address** of the base of the level 1 page table (**0x01000**) is stored in a special register named Page Table Base Register. The system uses **20-bit** virtual address and **20-bit** physical address. The following figure summarizes the page table structure and shows the breakdown of a virtual address in this system. The size of both level 1 and level 2 page table entries is **4 bytes** and the memory is byte-addressed. Assume that all pages and all page tables are loaded in the main memory. Each entry of the level 1 page table contains the **physical address** of the base of each level 2 page tables, and each of the level 2 page table entries holds the **PTE** of the data page (the following diagram is not drawn to scale). As described in the following diagram, L1 index and L2 index are used as an index to locate the corresponding **4-byte entry** in Level 1 and Level 2 page tables.

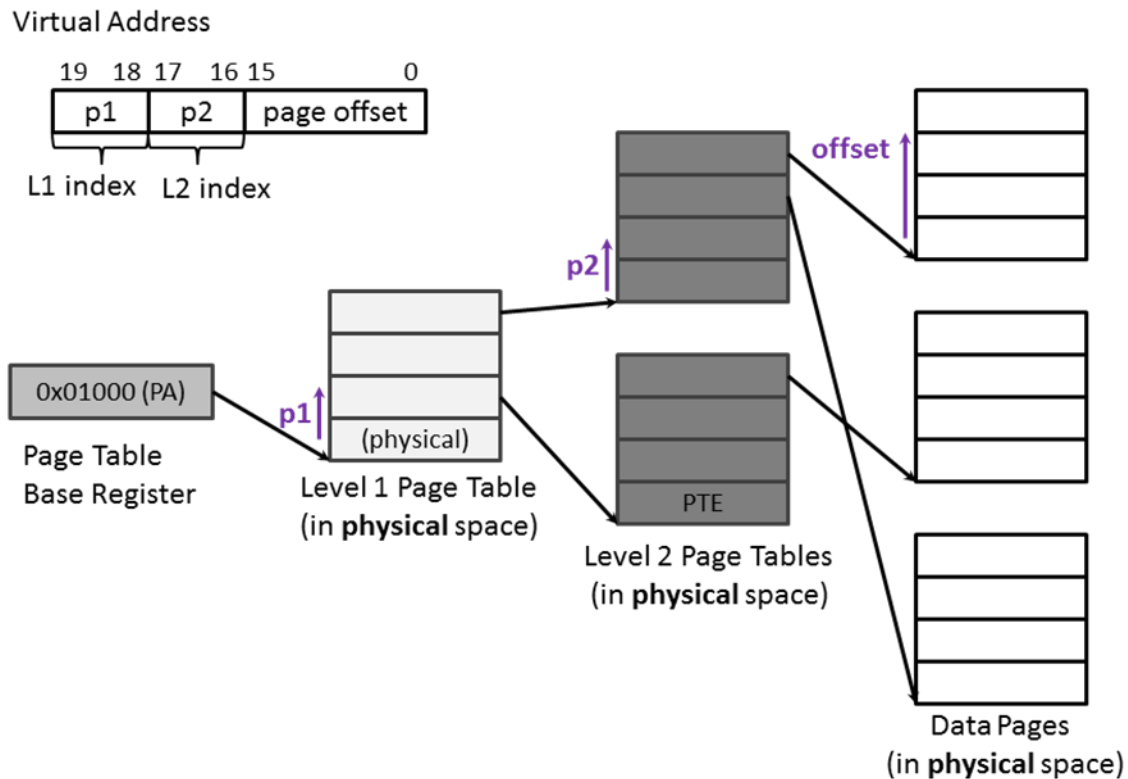

A PTE in level 2 page tables can be broken into the following fields (Don't worry about status bits for the entire part).

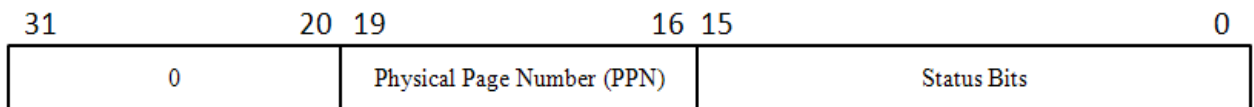

Problem M5.9.A

Assuming the TLB is initially at the state given below and the initial memory state is to the right, what will be the final TLB states after accessing the virtual address given below? Please fill out the table with the final TLB states. You only need to write VPN and PPN fields of the TLB. The TLB has 4 slots and is fully associative and if there are empty lines they are taken first for new entries. Also, translate the virtual address (VA) to the physical address (PA). *For your convenience, we separated the page number from the rest with the colon “:”.*

VPN	PPN
0x8	0x3

Initial TLB states

Address (PA)

0x0:104C	0x7:1A02
0x0:1048	0x3:0044
0x0:1044	0x2:0560
0x0:1040	0xA:0FFF
0x0:103C	0xC:D031
0x0:1038	0xA:6213
0x0:1034	0x9:1997
0x0:1030	0xD:AB04
0x0:102C	0xF:A000
0x0:1028	0x6:0020
0x0:1024	0x5:1040
0x0:1020	0x4:AA40
0x0:101C	0x3:10EF
0x0:1018	0xB:EA46
0x0:1014	0x2:061B
0x0:1010	0x1:0040
0x0:100C	0x0:1020
0x0:1008	0x0:1048
0x0:1004	0x0:1010
0x0:1000	0x0:1038

The part of the memory
(in physical space)

Virtual Address:

0xE:17B0 (1110:0001011110110000)

VPN	PPN
0x8	0x3

Final TLB states

VA 0xE17B0 => PA _____

Problem M5.9.B

What is the total size of memory required to store both the level 1 and 2 page tables?

Problem M5.9.C

Ben Bitdiddle wanted to reduce the amount of physical memory required to store the page table, so he decided to only put the level 1 page table in the physical memory and use the virtual memory to store level 2 page tables. Now, each entry of the level 1 page table contains the **virtual address** of the base of each level 2 page tables, and each of the level 2 page table entries contains the **PTE** of the data page (the following diagram is not drawn to scale). Other system specifications remain the same. (The size of both level 1 and level 2 page table entries is **4 bytes**.)

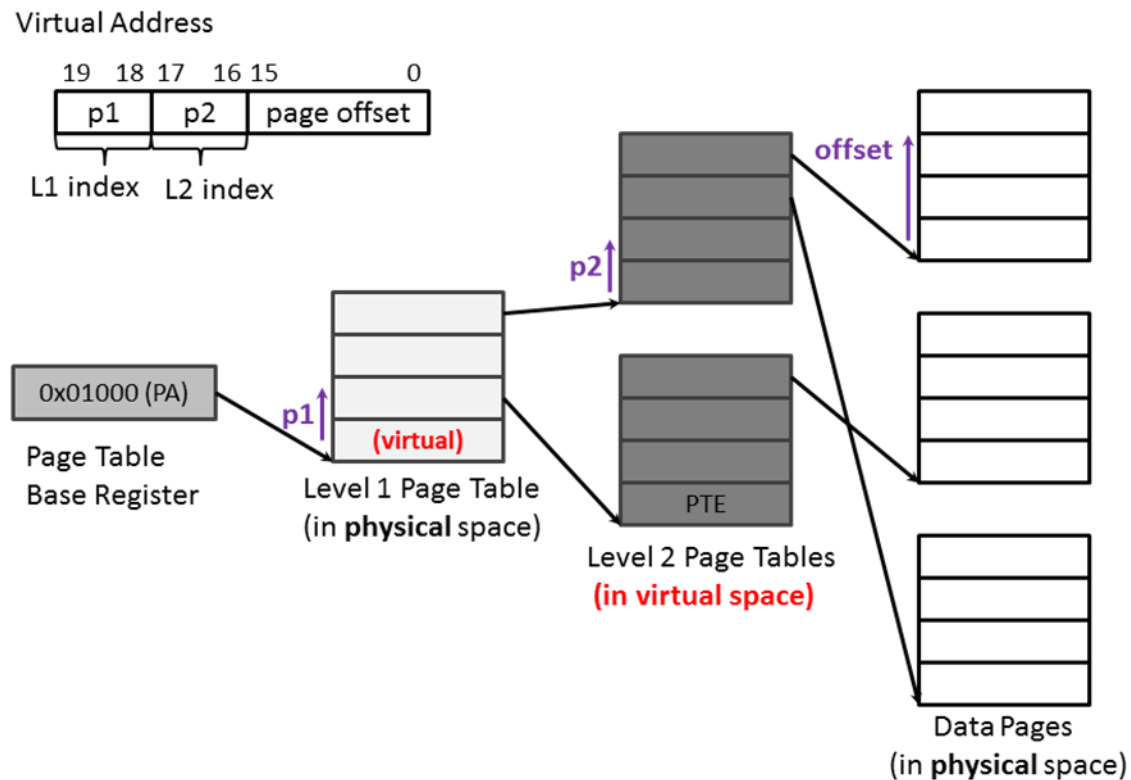

Ben's design with 2-level hierarchical page table

Assuming the TLB is initially at the state given below and the initial memory state is to the right (**different** from M5.9.A), what will be the final TLB states after accessing the virtual address given below? Please fill out the table with the final TLB states. You only need to write VPN and PPN fields of the TLB. The TLB has 4 slots and it is fully associative and if there are empty lines they are taken first for new entries. Also, translate the virtual address to the physical address. *Again, we separated the page number from the rest with the colon “:”*.

VPN	PPN
0x8	0x1

Initial TLB states

Address (PA)	
.....
0x1:1048	0x3:0044
0x1:1044	0x2:0560
0x1:1040	0x1:0FFF
0x1:103C	0x1:D031
0x1:1038	0xA:6213
0x1:1034	0x9:1997
.....
0x1:0018	0xF:A000
0x1:0014	0x6:0020
0x1:0010	0x1:1040
0x1:000C	0x4:AA40
0x1:0008	0x3:10EF
0x1:0004	0xB:EA46
.....
0x0:1010	0x1:0040
0x0:100C	0x0:1020
0x0:1008	0x2:0010
0x0:1004	0x8:0010
0x0:1000	0x8:1038

The part of the memory
(in physical space)

Virtual Address:

0xA:0708 (1010:0000011100001000)

VPN	PPN
0x8	0x1

Final TLB states

VA 0xA0708 => PA _____

Problem M5.9.D

Alice P. Hacker examines Ben's design and points out that his scheme can result in infinite loops. Describe the scenario where the memory access falls into infinite loops.