

Problem M10.1: Microprogramming and Bus-Based Architectures

Problem M10.1.A

Memory-to-Memory Add

Worksheet M10.1-1 shows one way to implement ADD_m in microcode.

Note that to maintain “clean” behavior of your microcode, no registers in the register file should change their value during execution (unless they are written to). This does not refer to the registers in the datapath (IR, A, B, MA). Thus, using asterisks for the load signals (ldIR, ldA, ldB, and ldMA) is acceptable as long as the correctness of your microcode is not affected.

Problem M10.1.B

Implementing DBNEZ Instruction

The question asked to jump to PC+4+offset. This ignores that the immediate value needs to be shifted left by 2 before it can be added to PC+4, to make sure we don't run into alignment problems. We did this because the data path given doesn't really have facilities for shifting.

Worksheet M10.1-2 shows one way to implement DBNEZ in microcode.

Problem M10.1.C

Implementing RETZ Instruction

Worksheet M10.1-3 shows one way to implement RETZ in microcode.

Problem M10.1.D

Implementing CALL Instruction

Worksheet M10.1-4 shows one way to implement CALL in microcode.

Problem M10.1.E

Instruction Execution Times

Instruction	Cycles
SUB R3, R2, R1	$3 + 3 = 6$
SUBI R2, R1, #4	$3 + 3 = 6$
SW R1, 0(R2)	$3 + 5 = 8$
BNEZ R1, label # (R1 == 0)	$3 + 2 = 5$
BNEZ R1, label # (R1 != 0)	$3 + 5 = 8$
BEQZ R1, label # (R1 == 0)	$3 + 5 = 8$
BEQZ R1, label # (R1 != 0)	$3 + 2 = 5$
J label	$3 + 3 = 6$
JR R1	$3 + 2 = 5$
JAL label	$3 + 4 = 7$
JALR R1	$3 + 4 = 7$

As discussed in Lecture 21, instruction execution includes the number of cycles needed to fetch the instruction. The lecture notes used 4 cycles for the fetch phase, while Worksheet 1 shows that this phase can actually be implemented in 3 cycles —either answer is fine. The above table uses 3 cycles for the fetch phase. Overall, SW, BNEZ (for a taken branch), and BEQZ (for a taken branch) take the most cycles to execute (8), while BNEZ (for a not-taken branch), BEQZ (for a not-taken branch) and JR take the fewest cycles (5).

State	PseudoCode	Ld IR	Reg Sel	Reg W	en Reg	ld A	ld B	ALUOp	en ALU	ld MA	Mem W	en Mem	Ex Sel	en Imm	μBr	Next State
FETCH0:	MA <- PC; A <- PC	0	PC	0	1	1	*	*	0	1	*	0	*	0	N	*
	IR <- Mem	1	*	*	0	0	*	*	0	*	0	1	*	0	N	*
	PC <- A+4; dispatch	0	PC	1	1	*	*	INC_A_4	1	*	*	0	*	0	D	*
...																
NOP0:	microbranch Back to FETCH0	0	*	*	0	*	*	*	0	*	*	0	*	0	J	FETCH0
ADDm0:	MA <- R[rs]	0	rs	0	1	*	*	*	0	1	*	0	*	0	N	*
	A <- Mem	0	*	*	0	1	*	*	0	*	0	1	*	0	N	*
	MA <- R[rt]	0	rt	0	1	0	*	*	0	1	*	0	*	0	N	*
	B <- Mem	0	*	*	0	0	1	*	0	*	0	1	*	0	N	*
	MA <- R[rd]	*	rd	0	1	0	0	*	0	1	*	0	*	0	N	*
	Mem <- A+B; fetch	*	*	*	0	*	*	ADD	1	*	1	1	*	0	J	FETCH0

Worksheet M10.1-1: Implementation of the ADDm instruction

State	PseudoCode	ld IR	Reg Sel	Reg W	en Reg	ld A	ld B	ALUOp	en ALU	Ld MA	Mem W	en Mem	Ex Sel	en Imm	μBr	Next State
FETCH0:	MA ← PC; A ← PC	*	PC	0	1	1	*	*	0	1	*	0	*	0	N	*
	IR ← Mem	1	*	*	0	0	*	*	0	*	0	1	*	0	N	*
	PC ← A+4; B ← A+4	0	PC	1	1	*	1	INC_A_4	1	*	*	0	*	0	D	*
...																
NOPO:	microbranch back to FETCH0	*	*	*	0	*	*	*	0	*	*	0	*	0	J	FETCH0
DBNEZ:	A ← rs	0	rs	0	1	1	0	*	0	*	*	0	*	0	N	*
	rs ← A – 1 μB to FETCH0 if zero	0	rs	1	1	*	0	DEC_A_1	1	*	*	0	*	0	Z	FETCH0
	A ← sExt16(IR)	*	*	*	0	1	0	*	0	*	*	0	sExt16	1	N	*
	PC ← A+B jump to FETCH0	*	PC	1	1	*	*	ADD	1	*	*	0	*	0	J	FETCH0

Worksheet M10.1-2: Implementation of the DBNEZ Instruction

State	PseudoCode	Ld IR	Reg Sel	Reg W	en Reg	ld A	ld B	ALUOp	en ALU	Ld MA	Mem W	en Mem	Ex Sel	en Imm	μBr	Next State
FETCH0:	MA ← PC; A ← PC	*	PC	0	1	1	*	*	0	1	*	0	*	0	N	*
	IR ← Mem	1	*	*	0	0	*	*	0	*	0	1	*	0	N	*
	PC ← A+4; B ← A+4	0	PC	1	1	*	1	INC_A_4	1	*	*	0	*	0	D	*
...																
NOP0:	microbranch back to FETCH0	*	*	*	0	*	*	*	0	*	*	0	*	0	J	FETCH0
retz0	A ← Reg[Rs]	0	Rs	0	1	1	*	*	0	*	*	0	*	0	N	*
retz1	A ← Reg[Rt] MA ← Reg[Rt] uBr to retz3 if zero	0	Rt	0	1	1	*	COPY_A	0	1	*	0	*	0	Z	retz3
retz2		*	*	*	0	*	*	*	0	*	*	0	*	0	J	FETCH0
retz3	PC ← MEM	0	PC	1	1	0	*	*	0	*	0	1	*	0	N	*
retz4	Reg[Rt] < A+4	*	Rt	1	1	*	*	INC_A_4	1	*	*	0	*	0	J	FETCH0

Worksheet M10.1-3: Implementation of the RETZ Instruction

State	PseudoCode	ld IR	Reg Sel	Reg W	en Reg	ld A	ld B	ALUOp	en ALU	Ld MA	Mem W	en Mem	Ex Sel	en Imm	μBr	Next State
FETCH0:	MA <- PC; A <- PC	*	PC	0	1	1	*	*	0	1	*	0	*	0	N	*
	IR <- Mem	1	*	*	0	0	*	*	0	*	0	1	*	0	N	*
	PC <- A+4; B <- A+4	0	PC	1	1	*	1	INC_A_4	1	*	*	0	*	0	D	*
...																
NOP0:	microbranch back to FETCH0	*	*	*	0	*	*	*	0	*	*	0	*	0	J	FETCH0
CALL:	MA <- R[ra]; A <- R[ra]	0	ra	0	1	1	0	*	0	1	*	0	*	0	N	*
	Mem <- B	0	*	*	0	0	0	COPY_B	1	*	1	1	*	0	N	*
	R[ra] <- A - 4	0	ra	1	1	*	0	DEC_A_4	1	*	*	0	*	0	N	*
	A <- sExt16(IR)	*	*	*	0	1	0	*	0	*	*	0	sExt16	1	N	*
	PC <- A+B; jump to FETCH0	*	PC	1	1	*	*	ADD	1	*	*	0	*	0	J	FETCH0

Worksheet M10.1-4: Implementation of the CALL Instruction

Problem M10.1.F

Exponentiation

In the given code, ‘m’ and ‘n’ are always nonnegative integers. Therefore, we don’t have to worry about the cases where ‘i’ is larger than ‘n’ or ‘j’ is larger than ‘m’. Also, for this problem, 0 raised to any power is just 0, while any nonzero value raised to the 0th power is 1. Note that the pseudo code that is given returns a value of 0 when 0 is raised to the 0th power. However, the actual `pow()` function in the standard C library returns a value of 1 for this case. We present the solution that implements the pseudo code given in the problem rather than C’s `pow()` function.

```
#
# R5: temp, R6: j
#

        ADD    R3, R0, R0        ; put 0 in result
        BEQZ  R1, _END_I        ; if m is 0, end
        ADDI  R3, R0, #1        ; put 1 in result
        BEQZ  R2, _END_I        ; if n is 0, the loop is over; we set
                                ; i equal to n and count down to 0—since
                                ; R2 does not have to be preserved, we
                                ; use it for i
        SUBI  R5, R1, #1        ; temp = m - 1
        BEQZ  R5, _END_I        ; if m is 1, the result will be 1,
                                ; so end the program

_START_I:
        ADD    R5, R0, R3        ; temp = result
        SUBI  R6, R1, #1        ; j = m - 1 (the number of times to
                                ; execute the second loop)

_START_J:
        ADD    R3, R3, R5        ; result += temp
        SUBI  R6, R6, #1        ; j--
        BNEZ  R6, _START_J      ; Re-execute loop until j reaches 0

_END_J:
        SUBI  R2, R2, #1        ; i--
        BNEZ  R2, _START_I      ; Re-execute loop until i reaches 0

_END_I:
```

To compute the number of instructions and cycles to execute this code, let us consider subsets of the code.

Code	# of instructions	# of cycles
ADD R3, R0, R0 BEQZ R1, _END_I	2	$6 \cdot 1 + 8 \cdot 1 = 14$ ($m = 0$) $6 \cdot 1 + 5 \cdot 1 = 11$ ($m > 0$)
ADDI R3, R0, #1 BEQZ R2, _END_I	2 (if $m > 0$)	$6 \cdot 1 + 8 \cdot 1 = 14$ ($n = 0$) $6 \cdot 1 + 5 \cdot 1 = 11$ ($n > 0$)
SUBI R5, R1, #1 BEQZ R5, _END_I	2 (if $m > 0$ and $n > 0$)	$6 \cdot 1 + 8 \cdot 1 = 14$ ($m = 1$) $6 \cdot 1 + 5 \cdot 1 = 11$ ($m > 1$)
_START_I: ADD R5, R0, R3 SUBI R6, R1, #1	$2n$ (if $m > 1$ and $n > 0$)	$(6 \cdot 2) \cdot n = 12n$
_START_J: ADD R3, R3, R5 SUBI R6, R6, #1 BNEZ R6, _START_J	$3n(m-1)$ (if $m > 1$ and $n > 0$)	$(6 \cdot 2 + 5 \cdot 1) \cdot n + (6 \cdot 2 + 8 \cdot 1) \cdot (m-2) \cdot n =$ $17n + 20n(m-2)$
_END_J: SUBI R2, R2, #1 BNEZ R2, _START_I	$2n$ (if $m > 1$ and $n > 0$)	$(6 + 8) \cdot n - 3 = 14n - 3$

From the above table, we can complete the table given in the problem.

m,n	Instructions	Cycles
0, 1	2	14
1, 0	4	25
2, 2	20	116
3, 4	46	282
M, N (M = 0)	2	14
M, N (M > 0, N = 0)	4	25
M, N (M = 1, N > 0)	6	36
M, N (M > 1, N > 0)	3N(M-1)+4N+6	20N(M-2)+43N+30

Problem M10.1.G

Microcontroller Jump Logic

One way to start designing the microcontroller jump logic is to write out a table of the input signals and the output bits. For clarity, the bits that encode the μ JumpTypes are labeled A, B and C, from left to right. The output bits are labeled H and L, also from left to right. So the table we need to implement is the following (where asterisks are for the input bits that we don't care about).

Input bits					Output bits	
A	B	C	Zero	Busy	H	L
0	0	0	*	*	0	0
0	0	1	*	0	0	0
0	0	1	*	1	0	1
0	1	0	*	*	1	0
1	0	0	*	*	1	1
1	1	0	0	*	0	0
1	1	0	1	*	1	0
1	1	1	0	*	1	0
1	1	1	1	*	0	0

Writing out boolean equations for the H and L output bits (by directly recognizing only the lines which have logical ones as output) we find

$$H = \overline{A}\overline{B}\overline{C} + \overline{A}\overline{B}C + \overline{A}B\overline{C} \cdot \overline{zero} + \overline{A}BC \cdot \overline{zero}$$

$$L = \overline{A}\overline{B}C \cdot \overline{busy} + \overline{A}B\overline{C}$$

Also, we do not care about the output when the μ Jump type is 011 or 101, since those are invalid encodings. Thus we can simplify the equations to

$$H = \overline{A}\overline{B} + \overline{A}B + \overline{A}C \cdot \overline{zero} + AC \cdot \overline{zero}$$

$$L = \overline{B}C \cdot \overline{busy} + \overline{A}\overline{B}$$

Drawing this out as gates we get

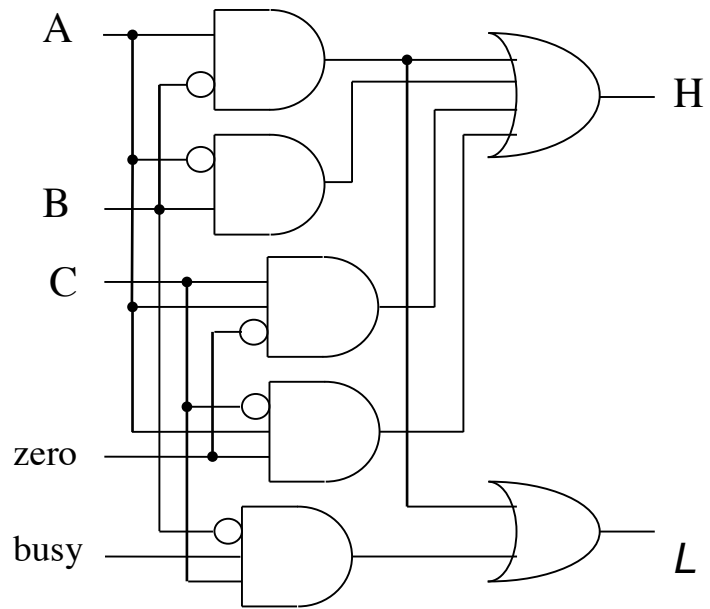

Problem M10.2: VLIW Programming

Problem M10.2.A

To get 1 cycle per vector element performance, we need to use loop unrolling and software pipelining. The original loop is unrolled four times and software pipelined. Two registers (**F3** and **F7**) are used for saving partial sums, which are summed at the end.

At the start of the program n may be any value. By making successive checks and providing fix-up code, n can be guaranteed to be positive and a multiple of 4 by the prolog.

```
// R1 - points to X
// R2 - points to Y
// R5 - n
// F7 - result

    // clear partial sum registers
    MOVI2FP F3,R0
    MOVI2FP F7,R0

    // clear temporary registers used for multiply results
    MOVI2FP F2,R0
    MOVI2FP F6,R0
    MOVI2FP F10,R0
    MOVI2FP F14,R0

    // n must be greater than 0
    SGT    R3,R5,R0
    BEQZ   R3,end    // if !(n>0) goto end

    // n must be greater than 0
    ANDI  R3,R5,#3
    BEQZ  R3,prolog

    // (n>0) && ((n%4)!=0)
    SUB   R5,R5,R3
L1:
    L.S   F3,0(R1); L.S   F4,0(R2); SUBI R3,R3,#1
    MUL.S F3,F3,F4; ADDI R1,R1,#4;
    ADD.S F7,F7,F3; ADDI R2,R2,#4; BNEZ R3,L1

    BEQZ  R5,end

    // (n>=4) && ((n%4)==0)
prolog:
    L.S   F0, 0(R1); L.S   F1, 0(R2); SUBI R5,R5,#4
    L.S   F4, 4(R1); L.S   F5, 4(R2); ADDI R1,R1,#16
    L.S   F8,-8(R1); L.S   F9, 8(R2); ADDI R2,R2,#16
    L.S   F12,-4(R1); L.S  F13,-4(R2); BEQZ R5,epilog

    L.S   F0, 0(R1); L.S   F1, 0(R2); MUL.S F2, F0, F1; SUBI R5,R5,#4
    L.S   F4, 4(R1); L.S   F5, 4(R2); MUL.S F6, F4, F5; ADDI R1,R1,#16
    L.S   F8,-8(R1); L.S   F9, 8(R2); MUL.S F10, F8, F9; ADDI R2,R2,#16
    L.S   F12,-4(R1); L.S  F13,-4(R2); MUL.S F14,F12,F13; BEQZ R5,epilog
```

```
loop:
  L.S  F0, 0(R1); L.S  F1, 0(R2); MUL.S  F2, F0, F1; ADD.S  F3,F3, F2; SUBI R5,R5,#4
  L.S  F4, 4(R1); L.S  F5, 4(R2); MUL.S  F6, F4, F5; ADD.S  F7,F7, F6; ADDI R1,R1,#16
  L.S  F8,-8(R1); L.S  F9, 8(R2); MUL.S  F10, F8, F9; ADD.S  F3,F3,F10; ADDI R2,R2,#16
  L.S  F12,-4(R1); L.S  F13,-4(R2); MUL.S  F14,F12,F13; ADD.S  F7,F7,F14; BNEZ R5,loop
```

```
epilog:
  MUL.S  F2, F0, F1; ADD.S  F3,F3, F2
  MUL.S  F6, F4, F5; ADD.S  F7,F7, F6
  MUL.S  F10, F8, F9; ADD.S  F3,F3,F10
  MUL.S  F14,F12,F13; ADD.S  F7,F7,F14
```

```
  ADD.S  F3,F3, F2
  ADD.S  F7,F7, F6
  ADD.S  F3,F3,F10
  ADD.S  F7,F7,F14
```

```
  ADD.S  F7,F7,F3
```

```
end:
```

Problem M10.3: Trace Scheduling

Problem M10.3.A

Program's control flow graph

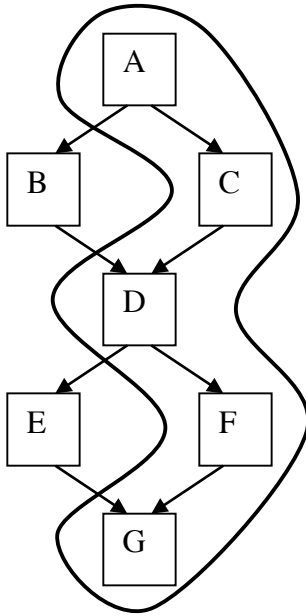

Decision tree

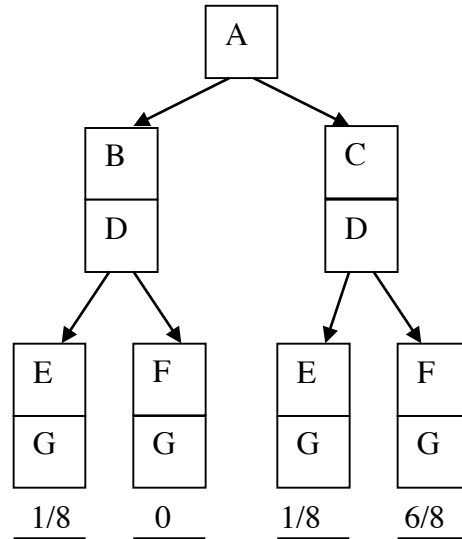

Problem M10.3.B

```

ACF: ld    r1, data
        div r3, r6, r7 ;; X <- V2/V3
        mul r8, r6, r7 ;; Y <- V2*V3
D:      andi r2, r1, 3 ;; r2 <- r1%4
        bnez r2, G
A:      andi r2, r1, 7 ;; r2 <- r1%8
        bnez r2, E
B:      div r3, r4, r5 ;; X <- V0/V1
E:      mul r8, r4, r5 ;; Y <- V0*V1
G:
  
```

Problem M10.3.C

Assume that the load takes x cycles, divide takes y cycles, and multiply takes z cycles. Approximately how many cycles does the original code take? (ignore small constants)
 $x + \max(y, z)$

Approximately how many cycles does the new code take in the best case? $\max(x, y, z)$

Problem M10.4: VLIW machines

Problem M10.4.A

See **Table M10.4-1** on the next page.

Problem M10.4.B

12 cycles, $2/12=0.17$ flops per cycle

Problem M10.4.C

3 instructions, because there are 5 memory ops and 5 ALU ops, and we can only issue 2 of them per instruction. (OR 4 instructions, because the slowest operation has a 4-cycle latency.)

Here is the resulting code.

add r1, r1, 4	add r2, r2, 4	ld f1, 0(r1)	ld f2, 0(r2)		fmul f4, f2, f1
add r3, r3, 4	add r4, r4, -1	ld f3, -4(r3)	st f4, -8(r1)	fadd f5, f4, f3	
	bnez r4, loop		st f5, -12(r3)		

for a particular instruction, white background corresponds to first iteration of the loop, grey background to the second iteration, yellow background to third, and blue to fourth. Note, one does not need to write the code to get an answer, because it's just a question of how many instructions are needed to express all the operations.

Problem M10.4.D

$2/3=0.67$ flops per cycle, 4 iterations at a time.

ALU1	ALU2	MU1	MU2	FADD	FMUL
<code>add r1, r1, 4</code>	<code>add r2, r2, 4</code>	<code>ld f1, 0(r1)</code>	<code>ld f2, 0(r2)</code>		
<code>add r3, r3, 4</code>	<code>add r4, r4, -1</code>	<code>ld f3, 0(r3)</code>			
					<code>fmul f4, f2, f1</code>
			<code>st f4, -4(r1)</code>	<code>fadd f5, f4, f3</code>	
	<code>bnez r4, loop</code>	<code>st f5, -4(r3)</code>			

Table M10.4-1: VLIW Program

Problem M10.4.E

We would need 5 instructions to execute two iterations and we would get $4/5=0.8$ flops/cycle.

Problem M10.4.F

Same as above - 0.8 flops/cycle. We are fully utilizing the memory units, so we can't execute more loops/cycle.

Problem M10.4.G

No. We need to unroll the loop once to have an even number of memory ops. Use of the rotating registers would not allow us to squeeze in more memory ops per iteration, so we'd still need 5 instructions.

Problem M10.4.H

This is actually rather tricky. The correct answer is 5, because without interlocks, we can use the registers just as values come in for them, using the execution units to "store" the loops. The intuitive answer is 100 though.

Problem M10.4.I

There are approximately 100 instructions required, because maximum latency will be 100 cycles.

Problem M10.5: VLIW & Vector Coding

Ben Bitdiddle has the following C loop, which takes the absolute value of elements within a vector.

```
for (i = 0; i < N; i++) {
    if (A[i] < 0)
        A[i] = -A[i];
}
```

Problem M10.5.A

```
; Initial Conditions:
;   R1 = N
;   R2 = &A[0]
```

```
        SGT R3, R1, R0
        BEQZ R3, end
loop:   LW R4, 0(R2)      | SUBI R1, R1, #1          ; R3 = (N > 0) | special case N ≤ 0
        SLT R5, R4, R0  | ADDI R2, R2, #4        ; R4 = A[i] | N--
        BEQZ R5, next   |                          ; R5 = (A[i] < 0) | R2 = &A[i+1]
        SUB R4, R0, R4  |                          ; skip if (A[i] ≥ 0)
        SW R4, -4(R2)   |                          ; A[i] = -A[i]
next:   BNEZ R1, loop   |                          ; store updated value of A[i]
end:                                         ; continue if N > 0
```

Average Number of Cycles: $\frac{1}{2} \cdot (6 + 4) = 5$

```
; SOLUTION #2
```

```
        SGT R3, R1, R0
        BNEZ R3, end
loop:   LW R4, 0(R2)      | SUBI R1, R1, #1          ; R3 = (N > 0) | special case N ≤ 0
        SLT R5, R4, R0  | ADDI R2, R2, #4        ; R4 = A[i] | N--
        BNEZ R5, next   | SUB R4, R0, R4         ; R5 = (A[i] < 0) | R2 = &A[i+1]
        SW R4, -4(R2)   |                          ; skip if (A[i] ≥ 0) | A[i] = -A[i]
next:   BNEZ R1, loop   |                          ; store updated value of A[i]
end:                                         ; continue if N > 0
```

Average Number of Cycles: $\frac{1}{2} \cdot (5 + 4) = 4.5$

NOTE: Although this solution minimizes code size and average number of cycles per element for this loop, it causes extra work because it subtracts regardless of whether it has to or not.

Problem M10.5.B

```
SGT R3, R1, R0
BNEZ R3, end
loop: LW R4, 0(R2)
      CMPLTZ P0, R4
      (P0) SUB R4, R0, R4
      (P0) SW R4, -4(R2)
end:

      SUBI R1, R1, #1
      ADDI R2, R2, #4
      BNEZ R1, loop

; R3 = (N > 0) | if N ≤ 0
; R4 = A[i] | N--
; P0 = (A[i]<0) | R2 = &A[i+1]
; A[i] = -A[i]
; store updated value of A[i]
; continue if N > 0
```

Average Number of Cycles: $\frac{1}{2} \cdot (4 + 4) = 4$ Cycles

Problem M10.5.C

```
; Initial Conditions:
;   R1 = N
;   R2 = &A[i]
```

```
R3 = N > 0
R4 = A[i]
R5 = N odd
R6 = A[i+1]
```

```
SGT R3, R1, R0
BEQZ R3, end
BEQZ R5, loop
CMPLTZ P0, R4
ADDI R2, R2, #4
(P0) SW R4, -4(R2)

      ANDI R5, R1, #1
      LW R4, 0(R2)
      SUBI R1, R1, #1
      (P0) SUB R4, R0, R4
      BEZ R1, end

loop: LW R4, 0(R2)
      CMPLTZ P0, R4
      (P0) SUB R4, R0, R4
      (P0) SW R4, 0(R2)
      ADDI R2, R2, #8

      SUBI R1, R1, #2
      LW R6, 4(R2)
      CMPLTZ P1, R6
      (P1) SUB R6 R0, R6
      (P1) SW R6 4(R2)
      BNEZ R1, loop

end:
```

Average Number of Cycles: 6 for 2 elements = 3 cycles per element

Problem M10.5.D

```
; Initial Conditions:
;   R1 = N
;   R2 = &A[i]

L.D F0, #0
MTC1 VLR R1          # operate on all N elements
CVM
LV V1, R2            # load A
SLTVS.D V1, F0       # setup the mask vector
SUBSV.D V1, F0, V1   # negate appropriate elements
SV R2, V1            # store back changes
```

Average Number of Cycles: $\approx (N/2 + N/2) / N \approx 1$ cycle per element (assuming chaining)

Note: Because there is only one ALU per lane, only the load and the SLT (Set-Less-Than) can be chained together, while the subtract and the store can be chained together. Execution time (per element) of the other instructions is negligible when N is large.

Problem M10.5.E

```
; assume m = known vector length
; Initial Conditions:
;   R1 = N
;   R2 = &A[i]

L.D F0, #0
ANDI R3, R1, (m-1)   # get N%m - assume m is a power of 2
MTC1 VLR R3          # operate on first N%m elements
LV V1, R2            # load A
SLTVS.D V1, F0       # setup the mask vector
SUBSV.D V1, F0, V1   # negate appropriate elements
SV R2, V1            # store back changes
SUB R1, R1, R3        # decrease i by N%m (i is divisible by m now)
SLLI R3, R3, #2       # (we're counting i down)
ADDI R2, R2, R3       # advance A pointer
BEQZ R1, end          # i == 0 -> done
ADDI R3, R0, m        #
MTC1 VLR R3          # operate on all elements

loop:
CVM
LV V1, R2            # load A
SLTVS.D V1, F0       # setup the mask vector
SUBSV.D V1, F0, V1   # negate appropriate elements
SV R2, V1            # store back changes
ADDI R2, R2, (m*4)    # advance A pointer
SUBI R1, R1, m        # decrease i by m
BNEZ R1, loop         # done?
```

end:
CVM

Problem M10.6: Predication and VLIW

Problem M10.6.A

```
l.s    f1, 0(r1)      ; f1 = *r1
seq.s  r5, f10, f1    ; r5 = (f10==f1)
cmpnez p1, r5        ; p1 = (r5!=0)
(p1)   add.s f2, f1, f11 ; if (p1) f2 = f1+f11
(!p1) add.s f2, f1, f12 ; if (!p1) f2 = f1+f12
s.s    f2, 0(r2)     ; *r2 = f2
```

Problem M10.6.B

See the next page (Table M10.6-2).

Label	integer op	floating point add	memory op	branch
loop:			l.s f1,0(r1)	
			l.s f3,4(r1)	
	addi r1, r1, #8	cmpnez p1, f1		
		cmpnez p3, f3		
		(p1) add.s f2, f1, f1		
		(p3) add.s f4, f3, f3		
			(p1) s.s f2, -8(r1)	
			(p3) s.s f4, -4(r1)	bneq r1, r2, loop

Table M10.6-1

label	integer op	floating point add	memory op	branch
			l.s f1,0(r1)	
			l.s f3,4(r1)	
	addi r1, r1, #8	cmpnez p1, f1		
		cmpnez p3, f3		beq r1, r2, epilog
loop:		(p1) add.s f2, f1, f1	l.s f1,0(r1)	
		(p3) add.s f4, f3, f3	l.s f3,4(r1)	
	addi r1, r1, #8	cmpnez p1, f1	(p1) s.s f2, -8(r1)	
		cmpnez p3, f3	(p3) s.s f4, -12(r1)	bneq r1, r2,loop
epilog:		(p1) add.s f2, f1, f1		
		(p3) add.s f4, f3, f3		
			(p1) s.s f2, -8(r1)	
			(p3) s.s f2, -4(r1)	

Table M10.6-2

Problem M10.7: Vector Machines

Problem M10.7.A

Consider the implementation of the C-code on the vector machine that executes in a minimum number of cycles. Assuming the following initial values, insert vector instructions to complete the implementation.

- R1 points to A[0]
- R2 points to B[0]
- R3 points to C[0]
- R4 contains the value 328

```
        ANDI R5, R4, 31          # 328 mod 32
        MTC1 VLR, R5            # set VLR to remainder
loop:
    LV    V1, R1                # load A
    LV    V2, R2                # load B
    LV    V3, R3                # load C
    MULV V4, V2, V1            # A * B
    ADDV V5, V3, V4            # C + A
    SV    V4, R1                # store A
    SV    V5, R3                # store C
    SLL  R7, R5, 2
    ADD  R1, R1, R7             # increment A ptr
    ADD  R2, R2, R7             # increment B ptr
    ADD  R3, R3, R7             # increment C ptr
    SUB  R4, R4, R5             # update loop counter
    LI   R5, 32                 # reset VLR to max
    MTC1 VLR, R5
    BGTZ R4, loop
```

Problem M10.7.B

The following **supplementary information** explains the diagram.

Scalar instructions execute in 5 cycles: fetch (**F**), decode (**D**), execute (**X**), memory (**M**), and writeback (**W**). A vector instruction is also fetched (**F**) and decoded (**D**). Then, it stalls (**—**) until its required vector functional unit is available. With no chaining, a dependent vector instruction stalls until the previous instruction finishes writing back ALL of its elements. A vector instruction is pipelined across all the lanes in parallel. For each element, the operands are read (**R**) from the vector register file, the operation executes on the load/store unit (**M**) or the ALU (**X**) or the MUL (**Y**), and the result is written back (**W**) to the vector register file. Assume that there is no structural conflict on the writeback port. A stalled vector instruction does not block a scalar instruction from executing.

LV₁ and LV₂ refer to the first and second LV instructions in the loop.

instr.	cycle																																											
	1	2	3	4	5	6	7	8	9	10	11	12	13	14	15	16	17	18	19	20	21	22	23	24	25	26	27	28	29	30	31	32	33	34	35	36	37	38	39	40				
LV ₁	F	D	R	M	M	M	M	W																																				
LV ₁				R	M	M	M	M	W																																			
LV ₁					R	M	M	M	M	W																																		
LV ₁						R	M	M	M	M	W																																	
LV ₂	F	D	—	—	—	R	M	M	M	M	W																																	
LV ₂							R	M	M	M	M	W																																
LV ₂								R	M	M	M	M	W																															
LV ₂									R	M	M	M	M	W																														
LV ₃		F	D	—	—	—	—	—	—	R	M	M	M	M	W																													
LV ₃											R	M	M	M	M	W																												
LV ₃												R	M	M	M	M	W																											
LV ₃													R	M	M	M	M	W																										
MULV			F	D	—	—	—	—	—	—	—	—	—	—	—	R	Y	Y	W																									
MULV																	R	Y	Y	W																								
MULV																		R	Y	Y	W																							
MULV																			R	Y	Y	W																						
ADDV				F	D	—	—	—	—	—	—	—	—	—	—	—	—	—	—	—	—	—	—	R	X	W																		
ADDV																									R	X	W																	
ADDV																										R	X	W																
ADDV																										R	X	W																
SV ₁				F	D	—	—	—	—	—	—	—	—	—	—	—	—	—	—	—	—	—	—	R	M	M	M	M	W															
SV ₁																										R	M	M	M	M	W													
SV ₁																											R	M	M	M	M	W												
SV ₁																											R	M	M	M	M	W												
SV ₂					F	D	—	—	—	—	—	—	—	—	—	—	—	—	—	—	—	—	—	—	—	—	—	—	—	—	—	—	—	—	—	—	—	—	—	—	—	—		
SV ₂																												R	M	M	M	M	W											
SV ₂																													R	M	M	M	M	W										
SV ₂																														R	M	M	M	M	W									

Problem M10.7.C

instr.	cycle																																											
	1	2	3	4	5	6	7	8	9	10	11	12	13	14	15	16	17	18	19	20	21	22	23	24	25	26	27	28	29	30	31	32	33	34	35	36	37	38	39	40				
LV ₁	F	D	R	M1	M2	M3	M4	W																																				
LV ₁				R	M1	M2	M3	M4	W																																			
LV ₁					R	M1	M2	M3	M4	W																																		
LV ₁						R	M1	M2	M3	M4	W																																	
LV ₂	F	D	—	—	—	R	M1	M2	M3	M4	W																																	
LV ₂							R	M1	M2	M3	M4	W																																
LV ₂								R	M1	M2	M3	M4	W																															
LV ₂									R	M1	M2	M3	M4	W																														
LV ₃	F	D	—	—	—	—	—	—	R	M1	M2	M3	M4	W																														
LV ₃										R	M1	M2	M3	M4	W																													
LV ₃											R	M1	M2	M3	M4	W																												
LV ₃												R	M1	M2	M3	M4	W																											
MULV		F	D	—	—	—	—	—	—	R	Y1	Y2	W																															
MULV											R	Y1	Y2	W																														
MULV												R	Y1	Y2	W																													
MULV													R	Y1	Y2	W																												
ADDV		F	D	—	—	—	—	—	—	—	—	—	—	—	R	X1	W																											
ADDV																R	X1	W																										
ADDV																	R	X1	W																									
ADDV																		R	X1	W																								
SV ₁			F	D	—	—	—	—	—	—	—	—	—	—	R	M1	M2	M3	M4	W																								
SV ₁																R	M1	M2	M3	M4	W																							
SV ₁																	R	M1	M2	M3	M4	W																						
SV ₁																		R	M1	M2	M3	M4	W																					
SV ₁			F	D	—	—	—	—	—	—	—	—	—	—	—	R	M1	M2	M3	M4	W																							
SV ₂																						R	M1	M2	M3	M4	W																	
SV ₂																							R	M1	M2	M3	M4	W																
SV ₂																								R	M1	M2	M3	M4	W															
		1	2	3	4	5	6	7	8	9	10	11	12	13	14	15	16	17	18	19																								

Problem M10.7.D

What is the performance (flops/cycle) of the program with chaining?

$2 \cdot 32 / 19$

Problem M10.7.E

Would loop unrolling of the assembly code improve performance without chaining? Explain. (You may rearrange the instructions when performing loop unrolling.)

Yes. We can overlap some of the vector memory instructions from different loops.

Problem M10.8: Vector Machines

Problem M10.8.A

The following **supplementary information** explains the diagram:

Scalar instructions execute in 5 cycles: fetch (**F**), decode (**D**), execute (**X**), memory (**M**), and writeback (**W**). A vector instruction is also fetched (**F**) and decoded (**D**). Then, it stalls (**—**) until its required vector functional unit is available. With no chaining, a dependent vector instruction stalls until the previous instruction finishes writing back all of its elements. A vector instruction is pipelined across all the lanes in parallel. For each element, the operands are read (**R**) from the vector register file, the operation executes on the load/store unit (**M**) or the ALU (**X**), and the result is written back (**W**) to the vector register file. A stalled vector instruction does not block a scalar instruction from executing. LV_1 and LV_2 refer to the first and second LV instructions in the loop.

instr.	cycle																																																					
	1	2	3	4	5	6	7	8	9	10	11	12	13	14	15	16	17	18	19	20	21	22	23	24	25	26	27	28	29	30	31	32	33	34	35	36	37	38	39	40														
LV ₁	F	D	R	M	M	M	M	W																																														
LV ₁				R	M	M	M	M	W																																													
LV ₁					R	M	M	M	M	W																																												
LV ₁						R	M	M	M	M	W																																											
LV ₂		F	D	—	—	—	R	M	M	M	M	W																																										
LV ₂							R	M	M	M	M	W																																										
LV ₂								R	M	M	M	M	W																																									
LV ₂									R	M	M	M	M	W																																								
ADDV			F	D	—	—	—	—	—	—	—	—	—	—	—	—	R	X	1	W																																		
ADDV																	R	X	1	W																																		
ADDV																	R	X	1	W																																		
ADDV																	R	X	1	W																																		
SUBVS			F	D	—	—	—	—	—	—	—	—	—	—	—	—	—	—	—	—	—	—	—	—	—	—	—	—	R	X	1	W																						
SUBVS																													R	X	1	W																						
SUBVS																														R	X	1	W																					
SUBVS																														R	X	1	W																					
SV			F	D	—	—	—	—	—	—	—	—	—	—	—	—	—	—	—	—	—	—	—	—	—	—	—	—	—	—	—	—	—	—	—	—	—	—	R	M	M	M	M	W										
SV																																											R	M	M	M	M	W						
SV																																													R	M	M	M	M	W				
SV																																														R	M	M	M	M	W			
ADDI				F	D	X	M	W																																														
ADDI					F	D	X	M	W																																													
ADDI						F	D	X	M	W																																												
SUBI							F	D	X	M	W																																											
BNEZ								F	D	X	M	W																																										
LV ₁									F	D	—	—	—	—	—	—	—	—	—	—	—	—	—	—	—	—	—	—	—	—	—	—	—	—	—	—	—	—	—	—	—	—	—	R	M	M	M	M	W					
LV ₁																																																R	M	M	M	M	W	
LV ₁																																																	R	M	M	M	M	W
LV ₁																																																	R	M	M	M	M	W

Problem M10.8.B

Vector processor configuration	Number of cycles between successive vector instructions					Total cycles per vector loop iter.
	LV ₁ , LV ₂	LV ₂ , ADDV	ADDV, SUBVS	SUBVS, SV	SV, LV ₁	
8 lanes, no chaining	4	9	6	6	4	29
8 lanes, chaining	4	5	4	2	4	19
16 lanes, chaining	2	5	2	2	2	13
32 lanes, chaining	1	5	2	2	1	11

Note, with 8 lanes and chaining, the SUBVS can not issue 2 cycles after the ADDV because there is only one ALU per lane. Also, since chaining is done through the register file, 2 cycles are required between the ADDV and SUBVS and between the SUBVS and SV even with 32 lanes (if bypassing was provided, only 1 cycle would be necessary).

Problem M10.8.C

Instr. Number	Instruction
I1	LV V1, R1
I2	LV V2, R2
I6	ADDI R1, R1, 128
I7	ADDI R2, R2, 128
I10	LV V5, R1
I11	LV V6, R2
I3	ADDV V3, V1, V2
I4	SUBVS V4, V3, R4
I5	SV R3, V4
I12	ADDV V7, V5, V6
I13	SUBVS V8, V7, R4
I8	ADDI R3, R3, 128
I14	SV R3, V8
I15	ADDI R1, R1, 128
I16	ADDI R2, R2, 128
I17	ADDI R3, R3, 128
I9	SUBI R5, R5, 32
I18	SUBI R5, R5, 32
I19	BNEZ R5, loop

This is only one possible solution. Scheduling the second iteration's LV's (I10 and I11) before the first iteration's SV (I5) allows the LV's to execute while the load/store unit would otherwise be idle. Interleaving instructions from the two iterations (for example, if I12 were placed between I3 and I4) could hide the functional unit latency seen with no chaining. However, doing so would delay the first SV (I5), and hence, increase the overall latency. This tension makes the optimal solution very tricky to find. Note that to preserve the instruction dependencies, I6 and I7 must execute before I10 and I11, and I8 must execute after I5 and before I14.

Problem M10.9: Vectorizing memcpy and strcpy

Problem M10.9.A

Because there is only one load/store unit, SV instruction should wait at least till the last element of the LV instruction is issued. Since there is only one lane, each SV and LV instruction takes 32 cycles to issue. In steady state, it takes 32 (LV) + 10 (dead time) + 32 (SV) + 10 (dead time) cycles per 32 elements, and 2.62 cycles per element. All scalar instructions can be overlapped with SV.

Problem M10.9.B

We can vectorize strcpy using SEQSV and CLZM. The algorithm is as follows. First, we load 32 elements. Second, we use SEQSV to check whether each element has '\0' or not. Third, we use CLZM to count the number of the elements before the first '\0' in the vector and set the vector length to that number. Then, we do a vector store. If no element has '\0' (i.e. the number is 32), we go back to the first step and load the next 32 elements. If a vector has '\0', strcpy ends. As discussed in the function definition, our strcpy copies one word at a time, and assumes that the string is word-aligned with the terminating character of 32-bit '\0'.

```
    ADD    R5,R1,R0      ; store destination address in R5
    ADD    R4,R2,R0      ; store source address in R4
    ADDI   R6,R0,#32
    MTC1   VLR,R6        ; set vector length to 32
    CVM
    MOVI2FP F0,R0
loop:
    LV     V1,R4
    ADDI   R4,R4,#128    ; bump source pointer
    SEQSV  F0,V1         ; setup the mask register
    CLZM   R6,VM         ; number elements before '\0'
    MTC1   VLR,R6
    SV     R5,V1
    ADDI   R5,R5,#128    ; bump destination pointer
    SUBI   R7,R6,#32     ;
    BEQZ   R7,loop      ; if no element has '\0' goto loop
    SLLI   R6,R6,#2     ; move destination pointer to
    SUBI   R5,R5,#128    ; the end of the string
    ADD    R5,R5,R6      ; copy '\0'
```

Problem M10.9.C

Without vector chaining, `strcpy` takes more cycles per element than `memcpy` since it has one additional vector instruction, `SEQSV`. It takes $32+10$ (`LV`) + 32 (`SEQSV`) + 1 (`CLZM`) + 1 (`MTC1`) + 32 (`SV`) + 10 (dead time) = 118 cycles per 32 elements or 3.69 cycles per element.

With vector chaining, the first element of `V1` can be bypassed to `SEQSV` instruction after 10 cycles. Store can be executed only after we get the value of `VLR`, that is, after `SEQSV`, `CLZM`, and `MTC1`. Therefore, it takes 10 (`LV`) + 32 (`SEQSV`) + 1 (`CLZM`) + 1 (`MTC1`) + 32 (`SV`) + 10 (dead time) = 86 cycles per 32 elements or 2.69 cycles per element.

In `memcpy`, both vector instructions (`SV` and `LV`) use the same functional unit. Therefore, the execution of two instructions cannot be overlapped even with vector chaining. Copying each element takes 2.62 cycles as in M10.9.A. With vector chaining, the performance of `strcpy` is comparable to that of `memcpy`.

Problem M10.10: Performance of Vector Machines

Problem M10.10.A

With 8 lanes, a 2-cycle dead time and no vector chaining, we get the following pipeline diagram.

	Cycle																						
	1	2	3	4	5	6	7	8	9	10	11	12	13	14	15	16	17	18	19	20	21	22	23
I1	F	D	R	X1	X2	W																	
I1				R	X1	X2	W																
I1					R	X1	X2	W															
I1						R	X1	X2	W														
I2		F	D	D	D	D			R	X1	X2	W											
I2									R	X1	X2	W											
I2										R	X1	X2	W										
I2											R	X1	X2	W									
I3			F	D	D	D	D	D	D	D	D	D	D	D	D	R	X1	X2	X3	W			
I3																	R	X1	X2	X3	W		
I3																	R	X1	X2	X3	W		
I3																	R	X1	X2	X3	W		

Since each vector has 32 elements, and there are 8 lanes, the vector register file needs to be read 4 times for each instruction. Although I2 does not need the results of I1, both instructions use the vector add unit, so I2 must wait until after I1 completes its last read, plus an additional 2 cycles for dead time before beginning its first read. And because there is no chaining, I3, which is dependent on I2, needs to wait until I2 has finished its last write back before beginning its first read.

The execution time is 18 cycles (from cycle 6 to cycle 23, inclusive).

Problem M10.10.B

With 8 lanes, no dead time and flexible chaining, we get the following pipeline diagram.

	Cycle																
	1	2	3	4	5	6	7	8	9	10	11	12	13	14	15	16	17
I1	F	D	R	X1	X2	W											
I1				R	X1	X2	W										
I1					R	X1	X2	W									
I1						R	X1	X2	W								
I2		F	D	D	D	D			X2	W							
I2								R	X1	X2	W						
I2									R	X1	X2	W					
I2										R	X1	X2	W				
I3			F	D	D	D	D	D	D	R	X1	X2	X3	W			
I3											R	X1	X2	X3	W		
I3												R	X1	X2	X3	W	
I3													R	X1	X2	X3	W

With no dead time, I2 can issue its first read after the last read of I1. And with flexible chaining, I3 can begin its first read in the same cycle as the first write of I2.

The execution time is 12 cycles (from cycle 6 to cycle 17, inclusive).

Problem M10.10.C

With 16 lanes, no dead time and flexible chaining, we get the following pipeline diagram.

	Cycle												
	1	2	3	4	5	6	7	8	9	10	11	12	13
I 1	F	D	R	X ₁	X ₂	W							
I 1				R	X ₁	X ₂	W						
I 2		F	D	D	R	X ₁							
I 2						R	X1	X2	W				
I 3			F	D	D	D	D	R	X ₁	X ₂	X ₃	W	
I 3									R	X ₁	X ₂	X ₃	W

Since each vector has 32 elements, and there are 16 lanes, the vector register file needs to be read 2 times for each instruction.

The execution time is 8 cycles (from cycle 6 to cycle 13, inclusive).