

Directory-Based Cache Coherence

Mengjia Yan

Computer Science & Artificial Intelligence Lab
M.I.T.

Based on slides from Daniel Sanchez

Valid/Invalid Example

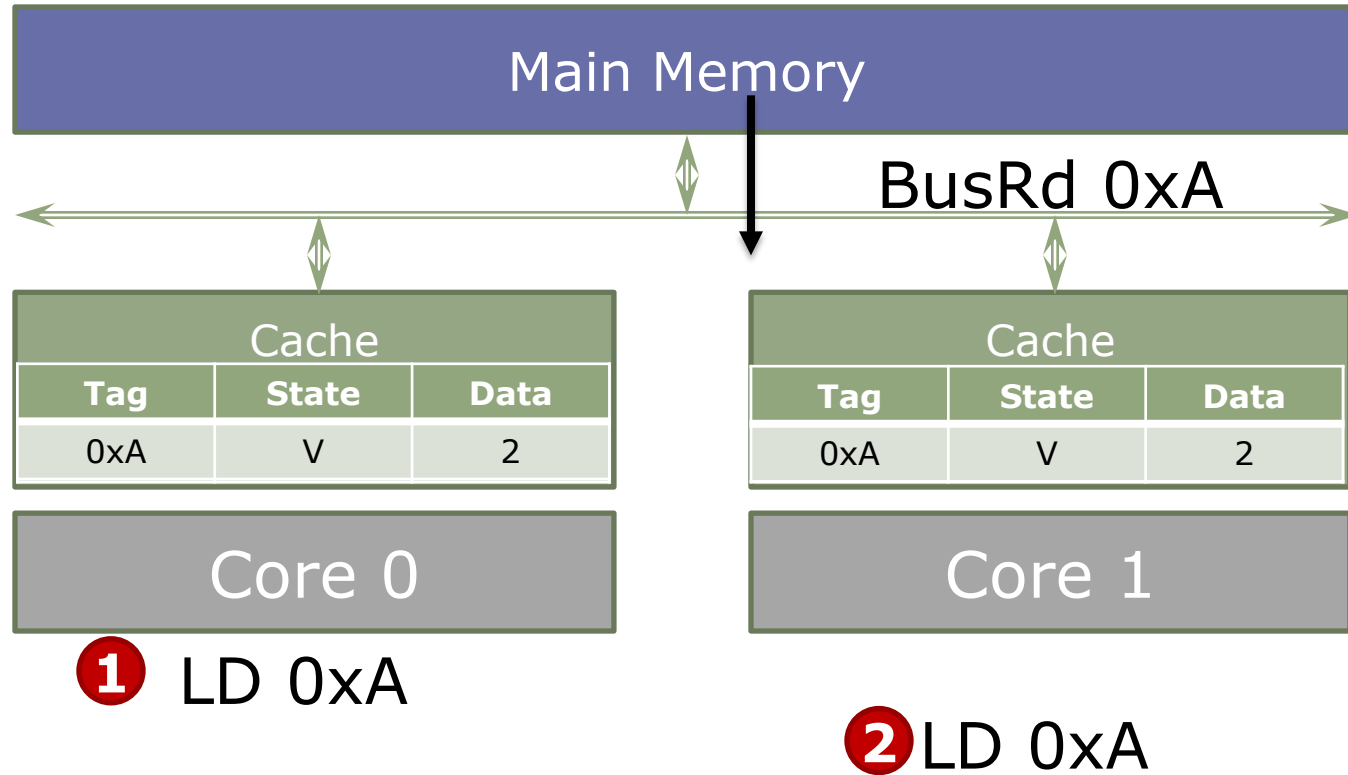

Maintaining Cache Coherence

It is sufficient to have hardware such that

- only one processor at a time has write permission for a location
- no processor can load a stale copy of the location after a write

⇒ A correct approach could be: (e.g. MSI)

write request:

The address is *invalidated* in all other caches *before* the write is performed

read request:

If a dirty copy is found in some cache, a write-back is performed before the memory is read

Directory-Based Coherence

(Censier and Feautrier, 1978)

Snoopy Protocols (Goodman 1983)

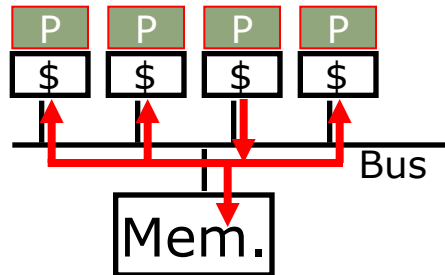

- Snoopy schemes **broadcast** requests over memory bus
- Difficult to scale to large numbers of processors
- Requires additional bandwidth to cache tags for snoop requests

Directory Protocols

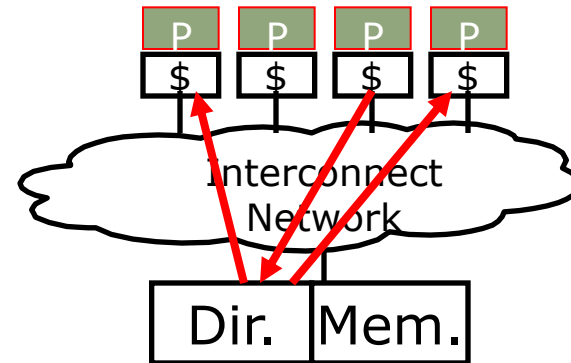

- Directory schemes send messages to **only those caches that might have the line**
- Can scale to large numbers of processors
- Requires extra directory storage to track possible sharers

An MSI Directory Protocol

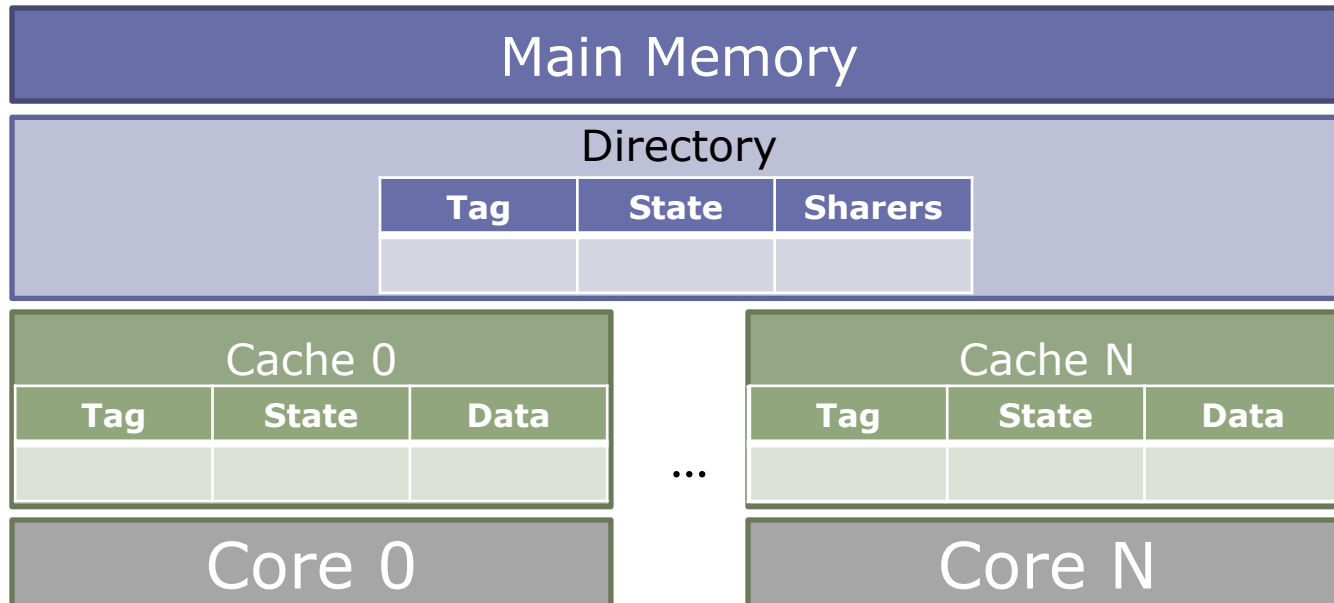

- Cache states: Modified (M) / Shared (S) / Invalid (I)
- Directory states:
 - Uncached (Un): No sharers
 - Shared (Sh): One or more sharers with read permission (S)
 - Exclusive (Ex): A single sharer with read & write permissions (M)
- Transient states not drawn for clarity; for now, assume no racing requests

MSI Protocol: Caches (1/3)

Transitions initiated by processor accesses:

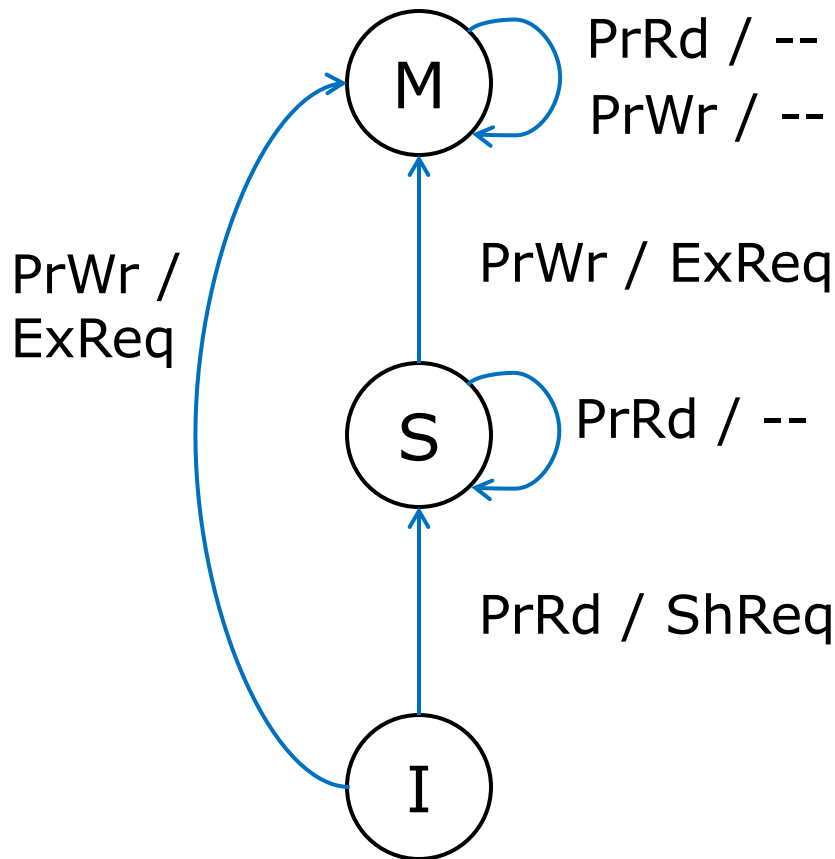

Actions
Processor Read (PrRd)
Processor Write (PrWr)
Shared Request (ShReq)
Exclusive Request (ExReq)

MSI Protocol: Caches (2/3)

Transitions initiated by directory requests:

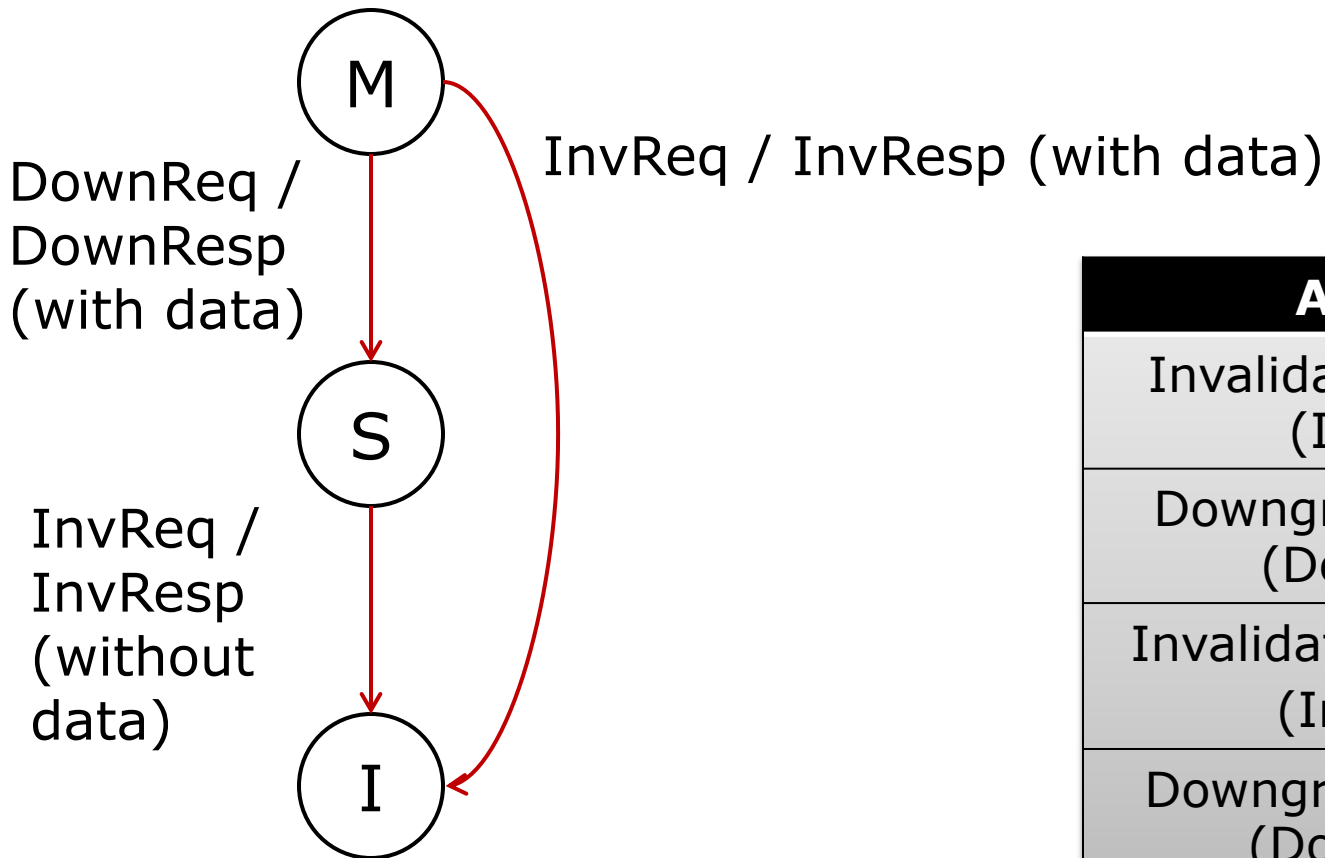

Actions
Invalidation Request (InvReq)
Downgrade Request (DownReq)
Invalidation Response (InvResp)
Downgrade Response (DownResp)

MSI Protocol: Caches (3/3)

Transitions initiated by evictions:

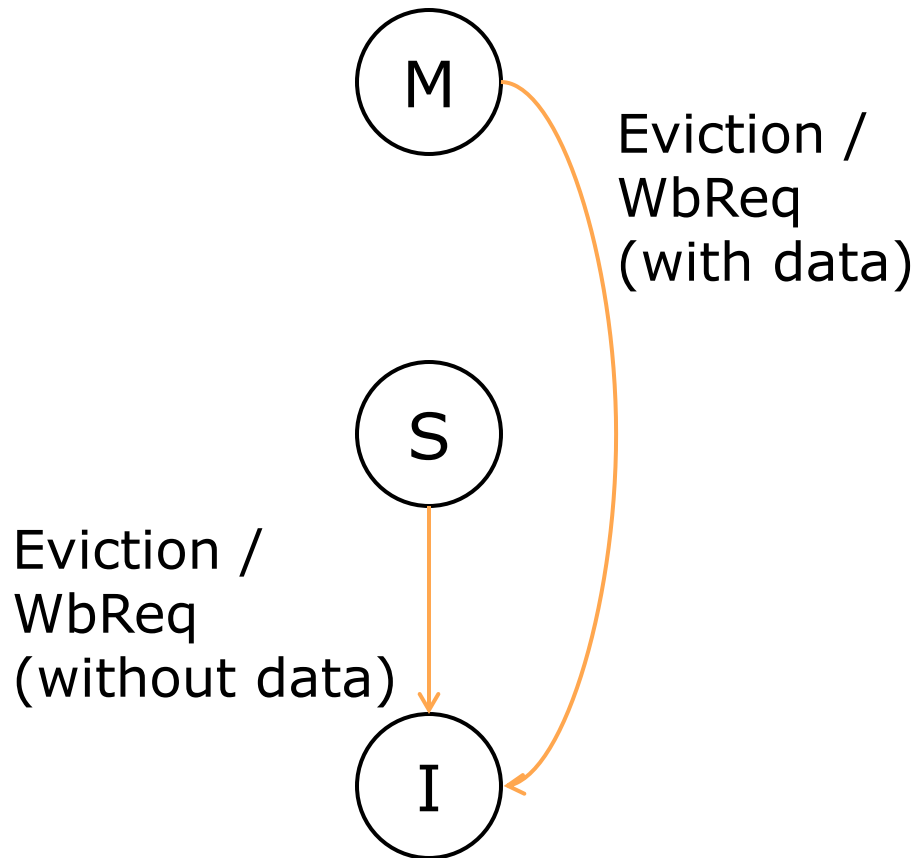

Actions
Writeback Request (WbReq)

MSI Protocol: Caches

- Transitions initiated by processor accesses
- Transitions initiated by directory requests
- Transitions initiated by evictions

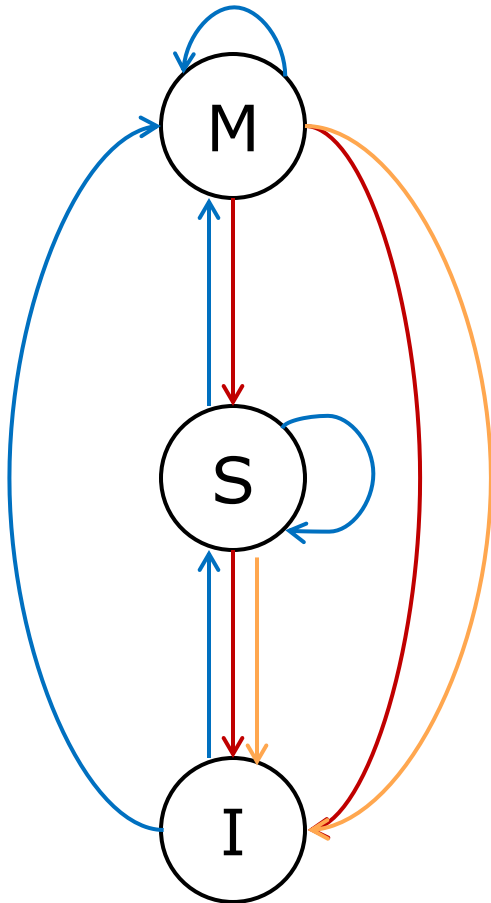

MSI Protocol: Directory (1/2)

Transitions initiated by data requests:

ExReq / Sharers = {P}; ExResp

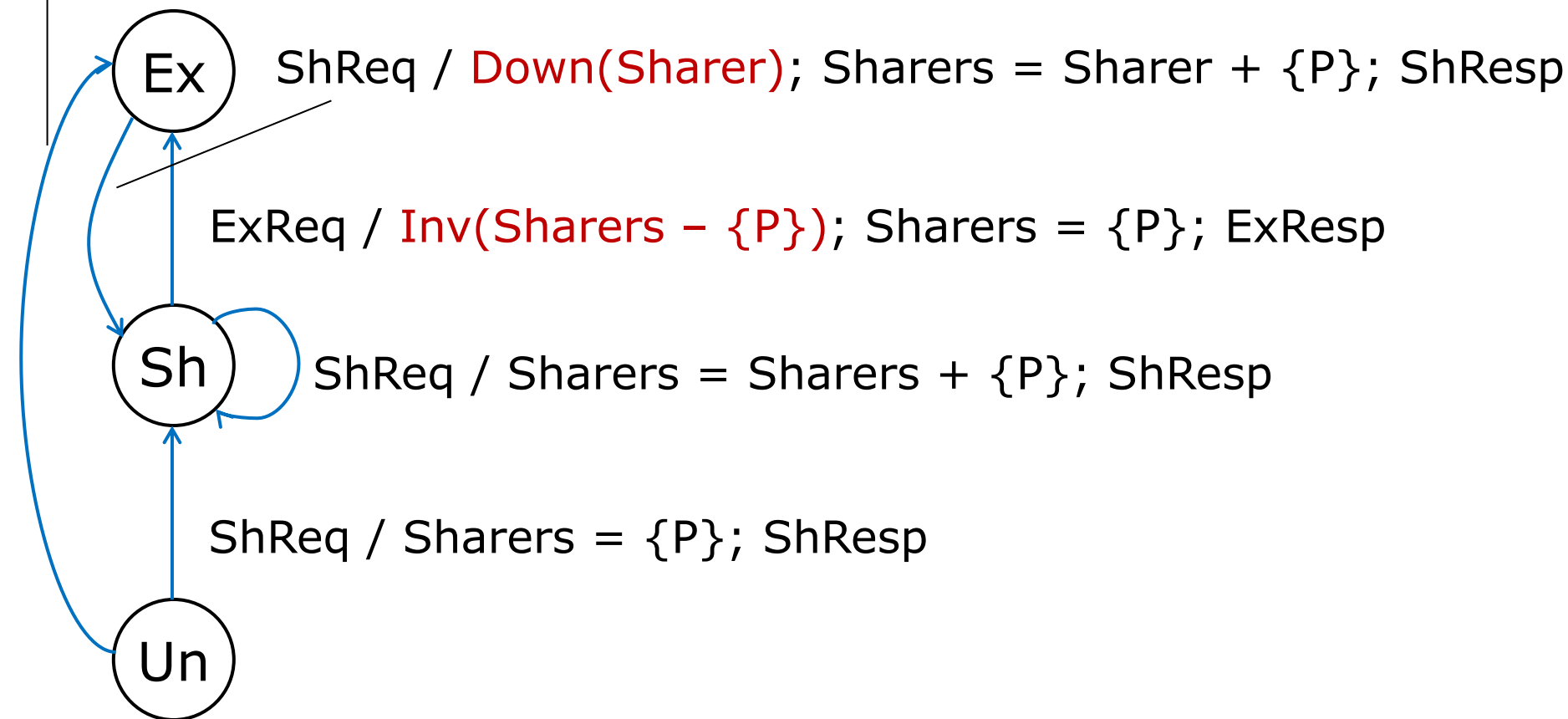

MSI Protocol: Directory (2/2)

Transitions initiated by writeback requests:

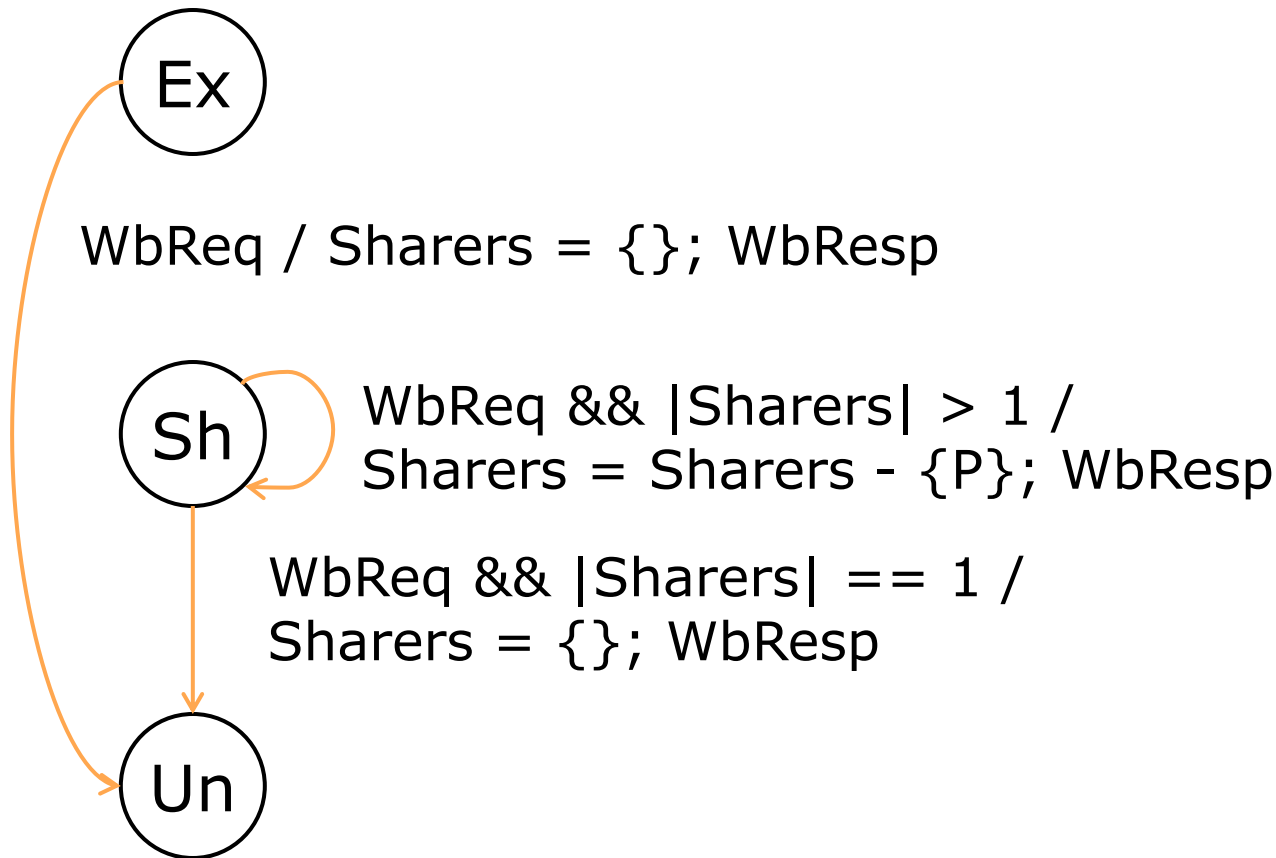

MSI Directory Protocol Example

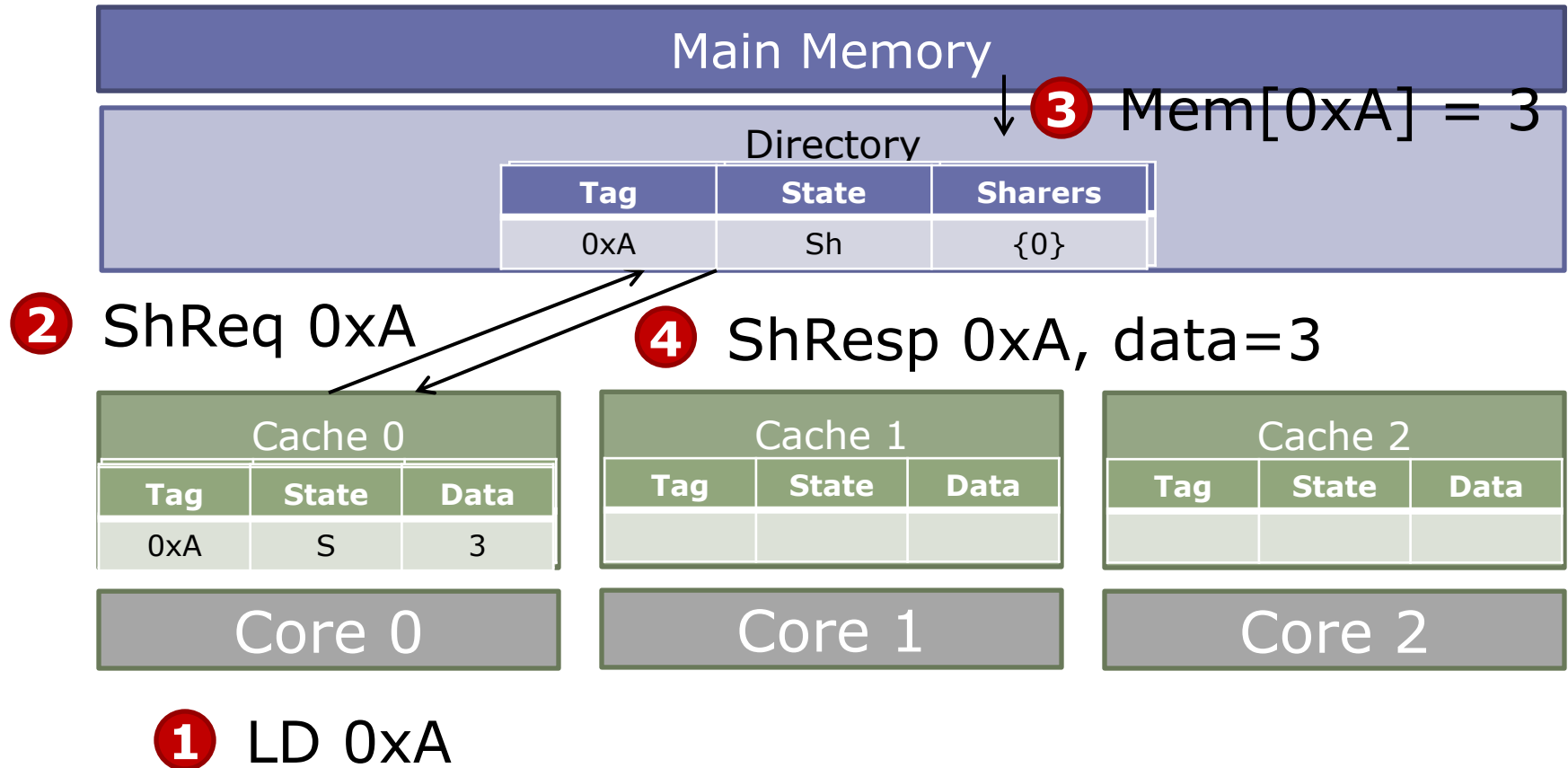

MSI Directory Protocol Example

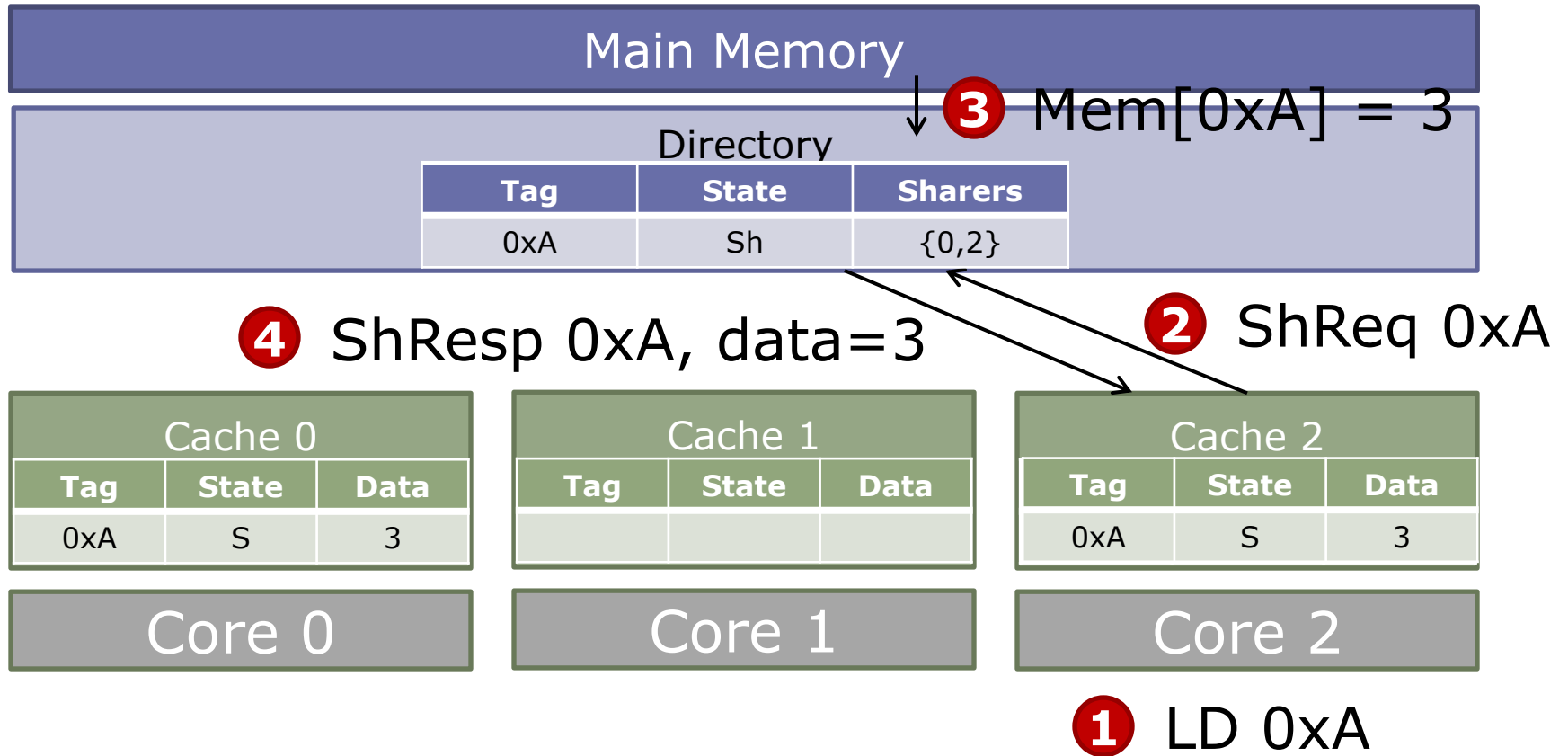

MSI Directory Protocol Example

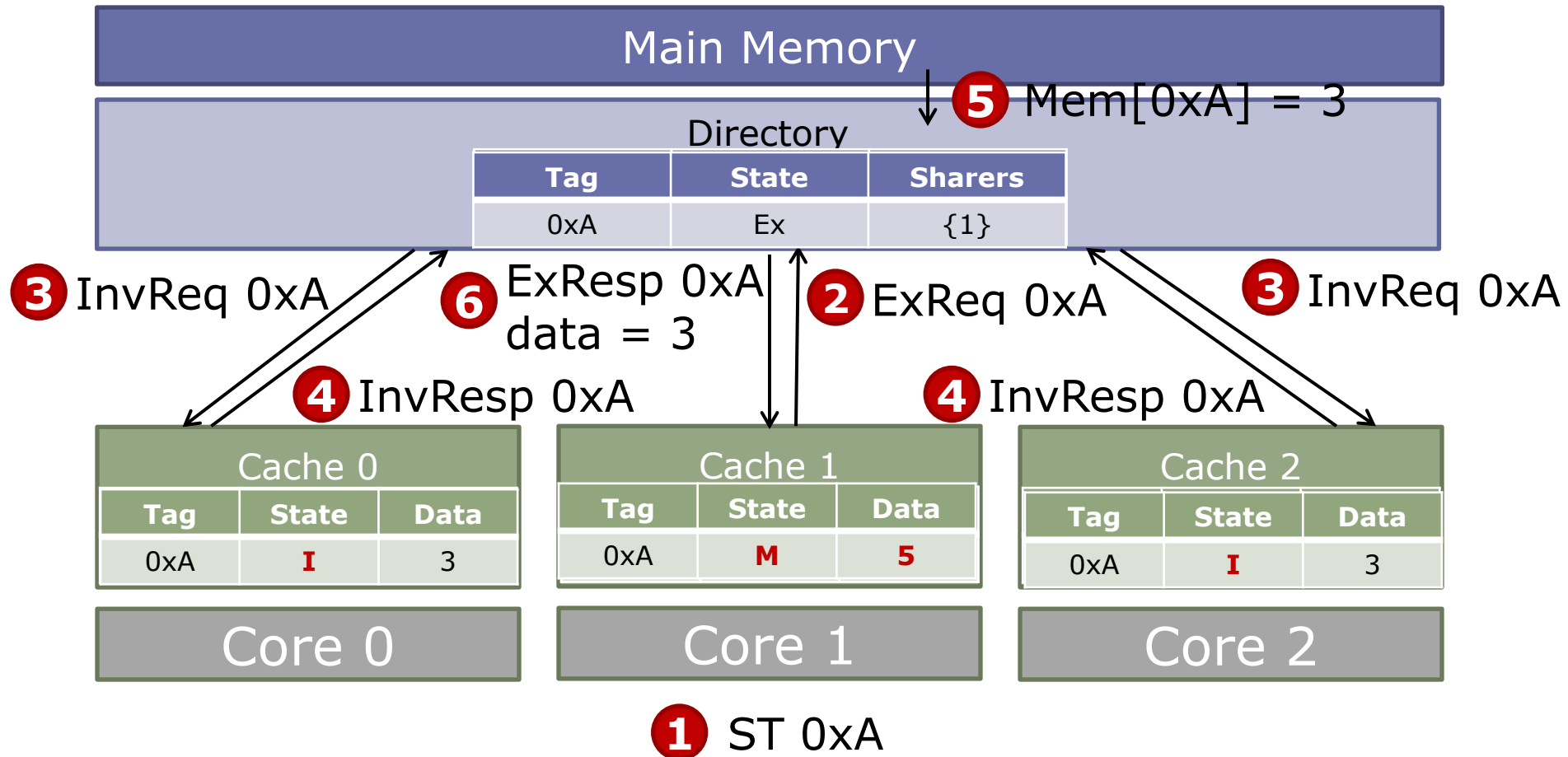

MSI Directory Protocol Example

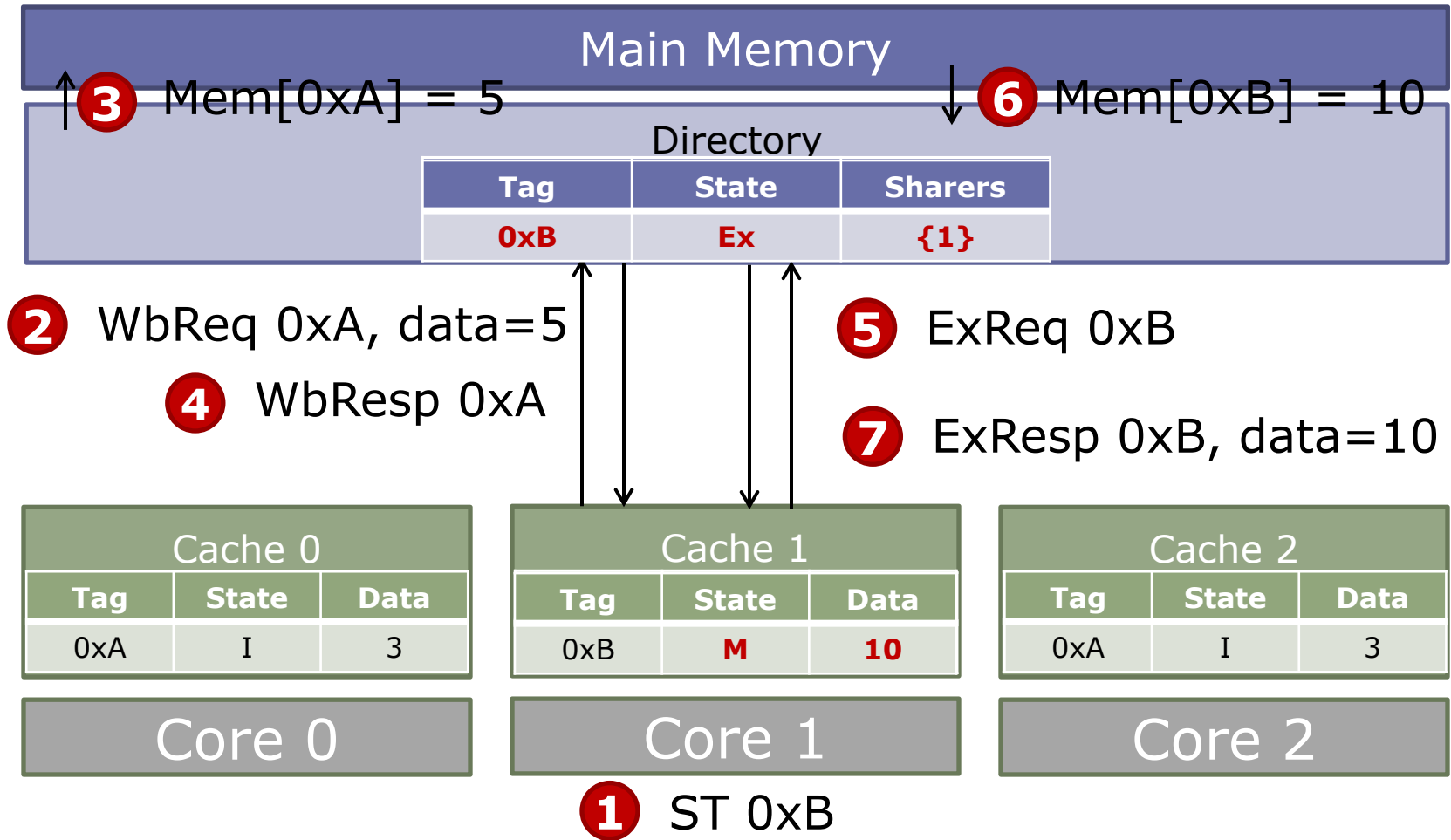

Why are 0xA's wb and 0xB's req serialized? **Structural dependence**

Possible solutions? **Buffer outside of cache to hold write data**

Miss Status Handling Register

MSHR – Holds load misses and writes outside of cache

MSHR entry

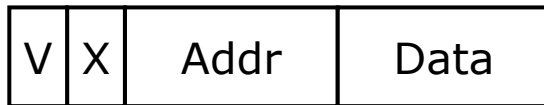

- On eviction/writeback
 - No free MSHR entry: stall
 - Allocate new MSHR entry
 - When channel available send WBReq and data
 - Deallocate entry on WBResp

Miss Status Handling Register

MSHR – Holds load misses and writes outside of cache

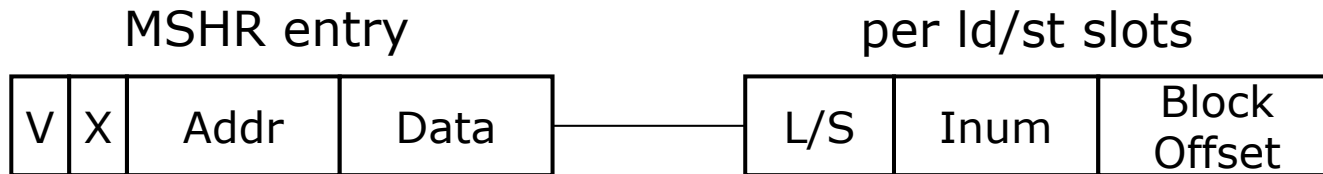

- On cache load miss
 - No free MSHR entry: stall
 - Allocate new MSHR entry
 - Send ShReq (or ExReq)
 - On *Resp forward data to CPU and cache
 - Deallocate MSHR

Miss Status Handling Register

MSHR – Holds load misses and writes outside of cache

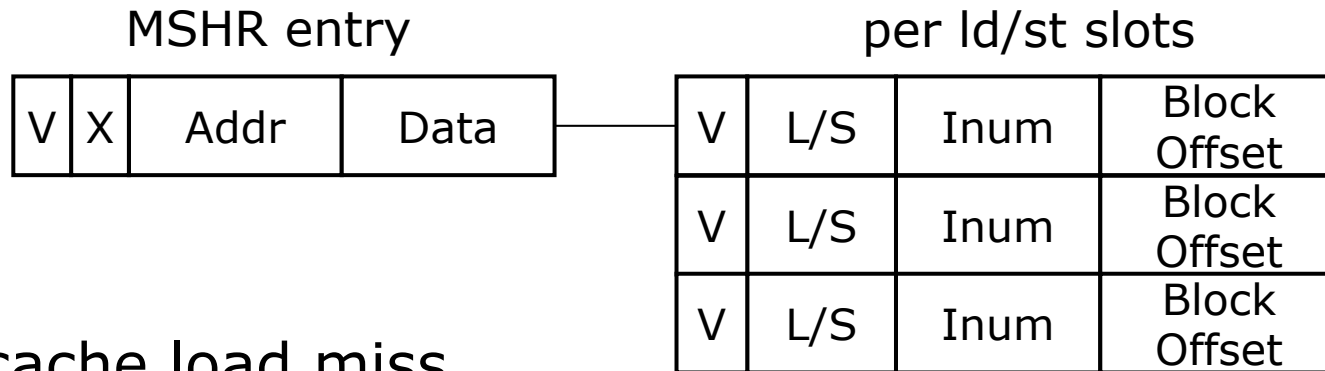

- On cache load miss
 - Look for matching address in MSHR
 - If not found
 - If no free MSHR entry: stall
 - Allocate new MSHR entry and fill in
 - If found, just fill in per Id/st slot
 - Send ShReq (or ExReq)
 - On *Resp forward data to CPU and cache
 - Deallocate MSHR

Per Id/st slots allow servicing multiple requests with one entry

Directory Organization

- Requirement: Directory needs to keep track of all the cores that are sharing a cache block
- Challenge: For each block, the space needed to hold the list of sharers grows with number of possible sharers...

Flat, Memory-based Directories

- Dedicate a few bits of main memory to store the state and sharers of every line
- Encode sharers using a bit-vector

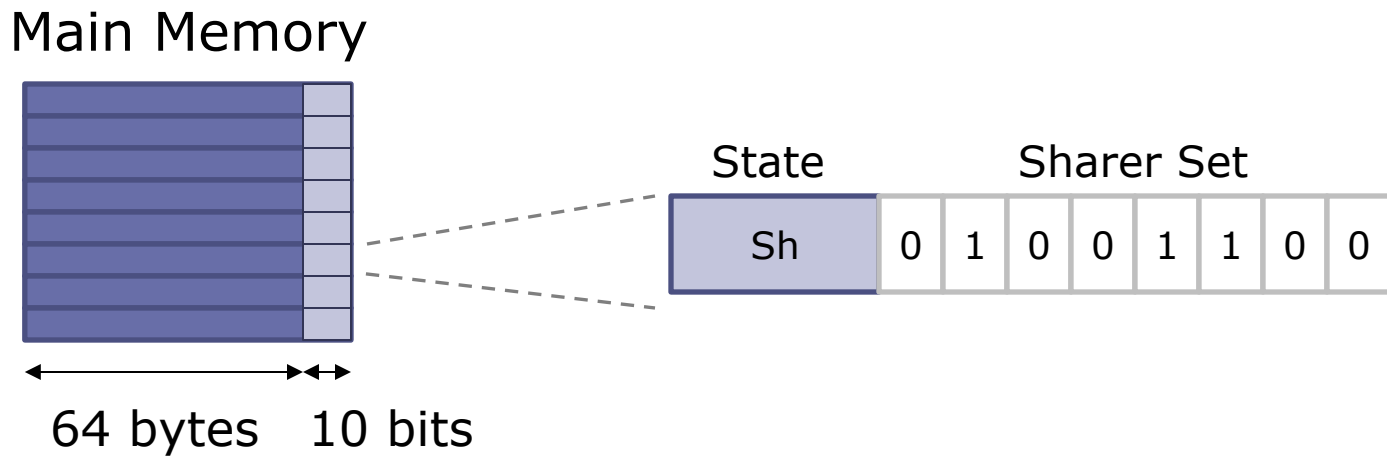

✓ Simple

✗ Slow

✗ Very inefficient with many processors ($\sim P$ bits/line)

Sparse Full-Map Directories

- Not every line in the system needs to be tracked – only those in private caches!
- Idea: Organize directory as a cache

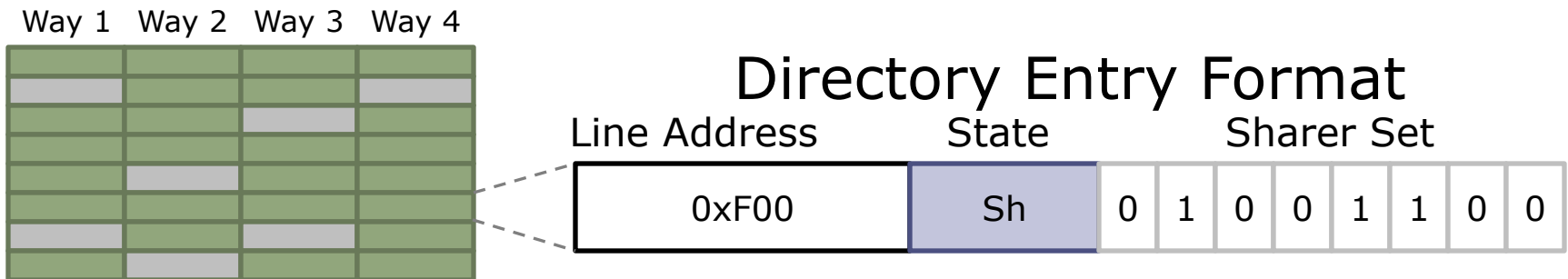

- ✓ Low latency, energy-efficient
- ✗ Bit-vectors grow with # cores → Area scales poorly
- ✗ Limited associativity → Directory-induced invalidations

Directory-Induced Invalidations

- To retain inclusion, must invalidate all sharers of an entry before reusing it for another address
- Example: 2-way set-associative sparse directory

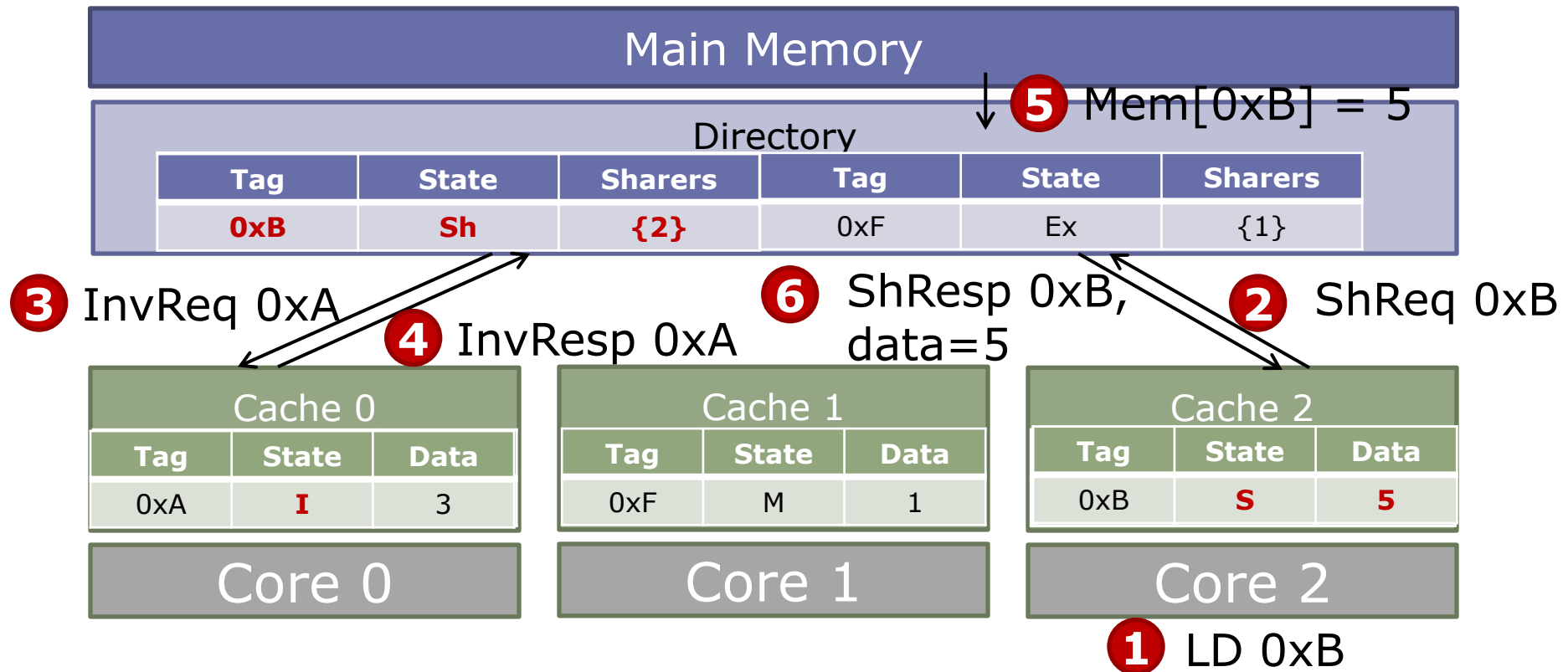

How many entries should the directory have?

Inexact Representations of Sharer Sets

- Coarse-grain bit-vectors (e.g., 1 bit per 4 cores)

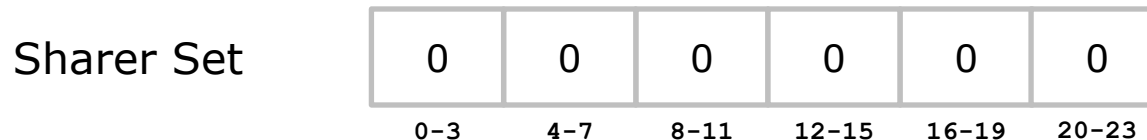

- Limited pointers: Maintain a few sharer pointers, on overflow mark 'all' and broadcast (or invalidate another sharer)

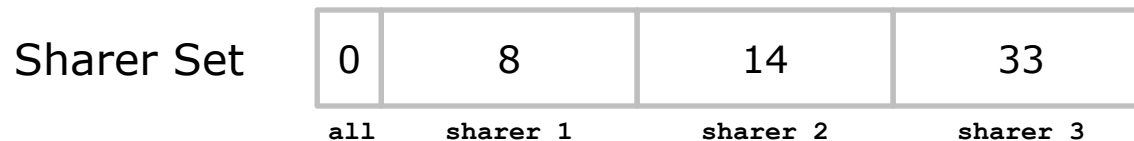

- Allow false positives (e.g., Bloom filters)
 - ✓ Reduced area & energy
 - ✗ Overheads still not scalable (these techniques simply play with constant factors)
 - ✗ Inexact sharers → Broadcasts, invalidations or spurious invalidations and downgrades

Protocol Races

- Directory serializes multiple requests for the same address
 - Same-address requests are queued or NACKed and retried
- But races still exist due to conflicting requests
- Example: Upgrade race

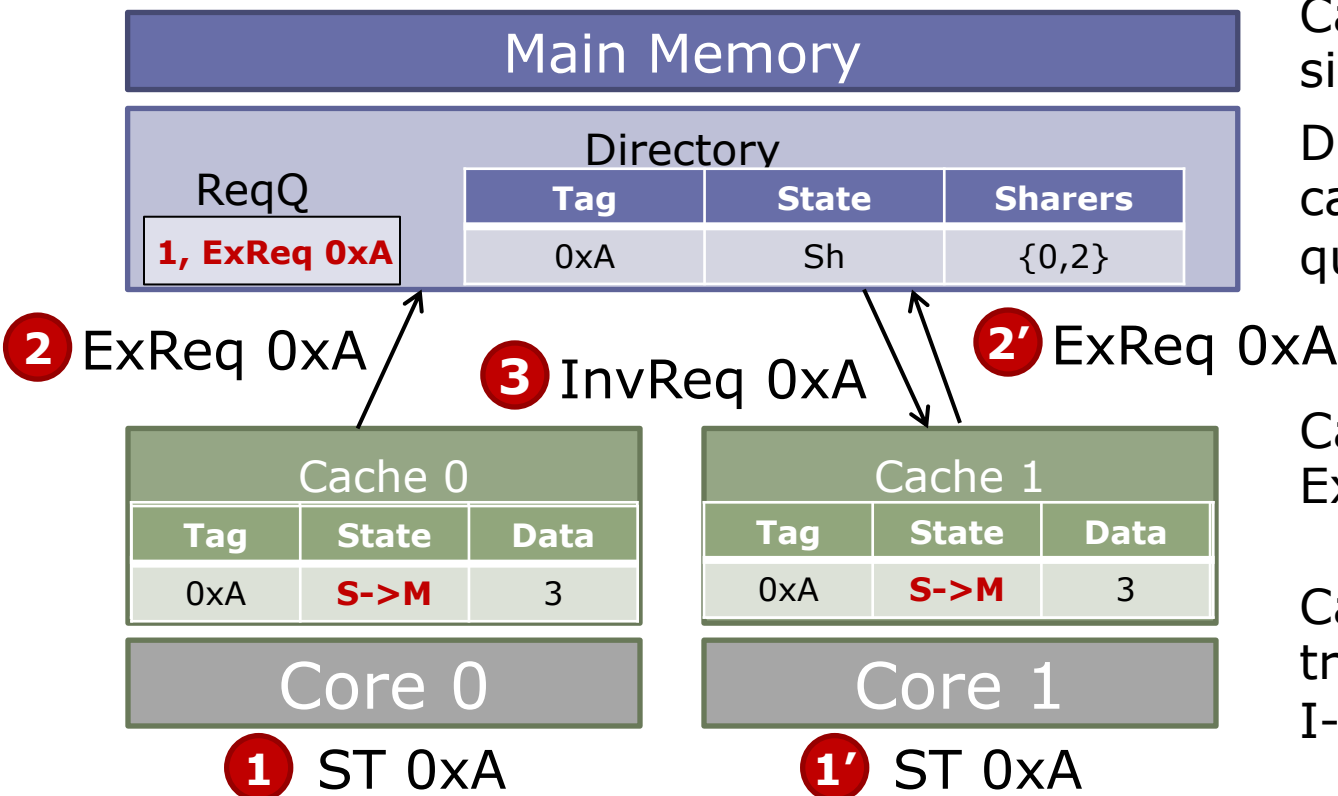

Caches 0 and 1 issue simultaneous ExReqs

Directory starts serving cache 0's ExReq, queues cache 1's

Cache 1 expected ExResp, but got InvReq!

Cache 1 should transition from S->M to I->M and send InvResp

Extra Hops and 3-Hop Protocols

Reducing Protocol Latency

- Problem: Data in another cache needs to pass through the directory, adding latency
- Optimization: Forward data to requester directly

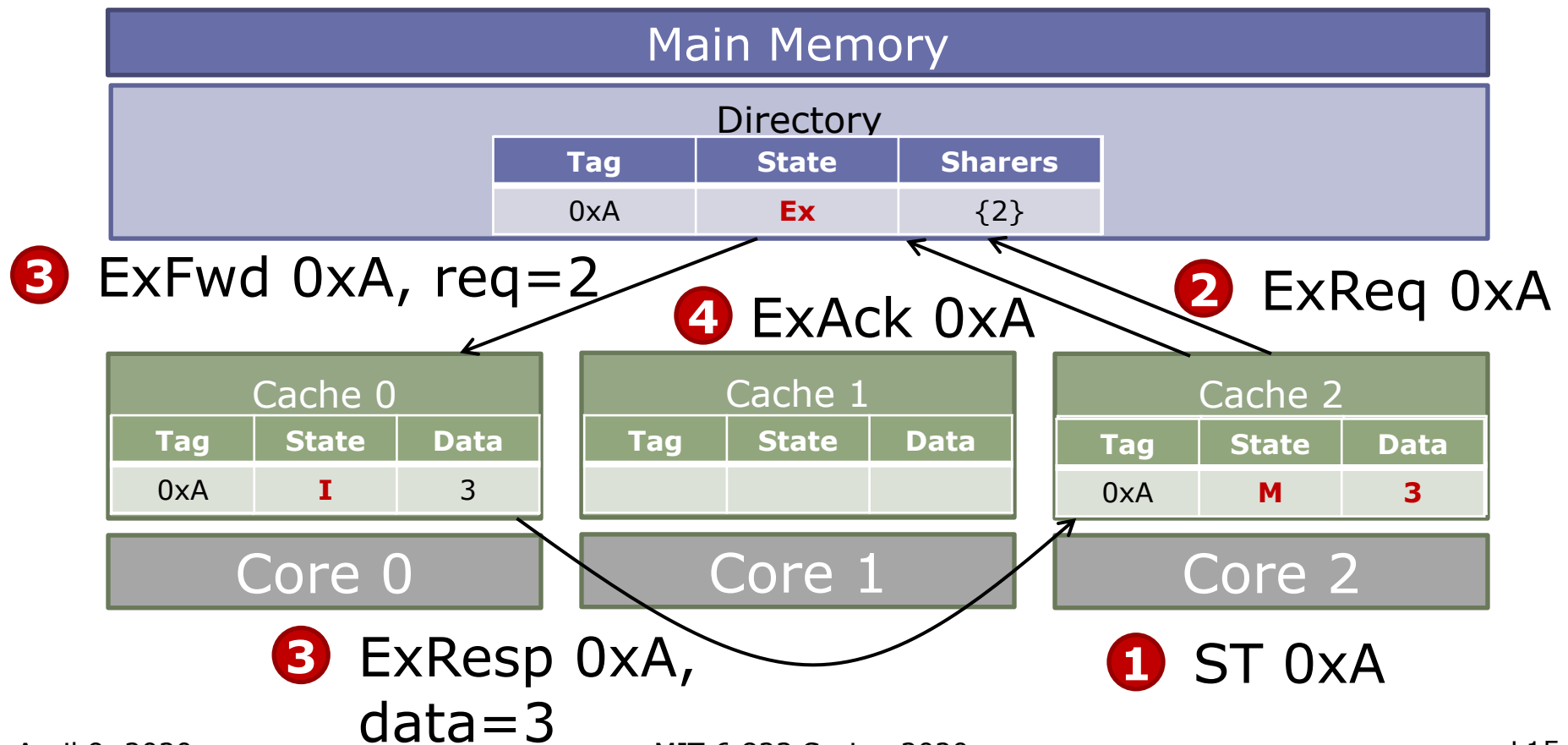

In-Cache Directories

- Common multicore memory hierarchy:

- 1+ levels of private caches
- A shared last-level cache
- Need to enforce coherence among private caches

- Idea: Embed the directory information in shared cache tags

- Shared cache must be inclusive
- Need extended directory if non-inclusive (Intel Skylake-X/SP)

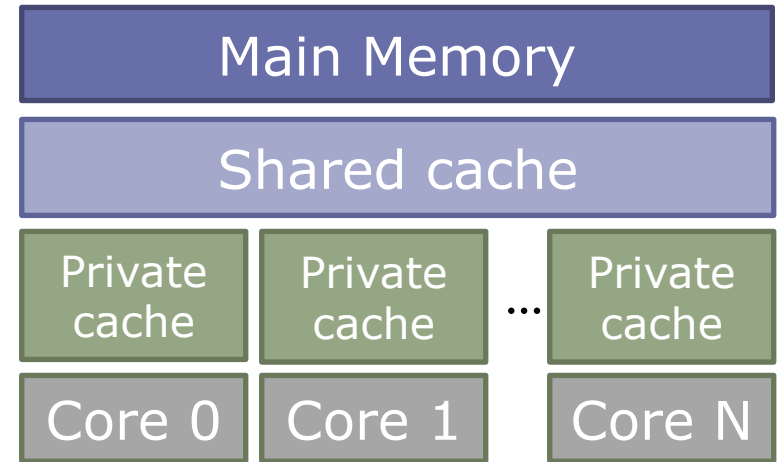

✓ Avoids tag overheads & separate lookups

✗ Can be inefficient if shared cache size \gg sum(private cache sizes)

Coherence in Multi-Level Hierarchies

- Can use the same or different protocols to keep coherence across multiple levels
- Key invariant: Ensure sufficient permissions in all intermediate levels
- Example: 8-socket Xeon E7 (8 cores/socket)

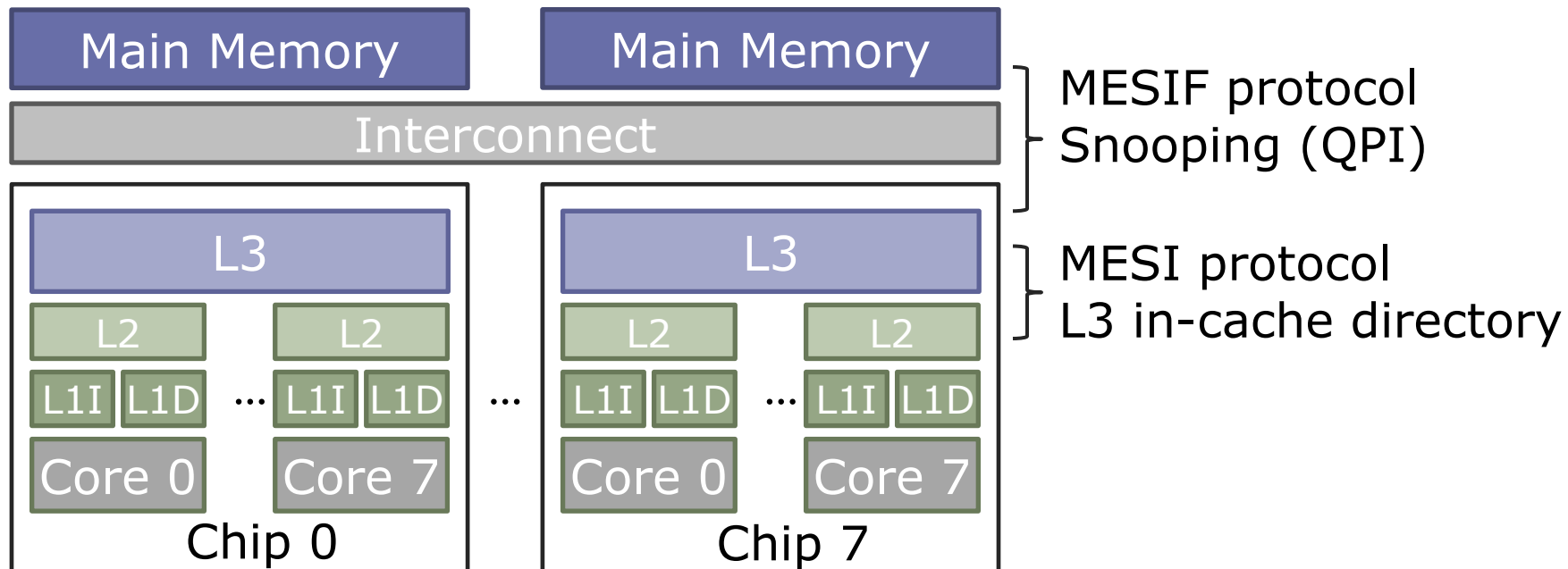

Avoiding Protocol Deadlock

- Protocols can cause deadlocks even if network is deadlock-free! (*more on this later*)

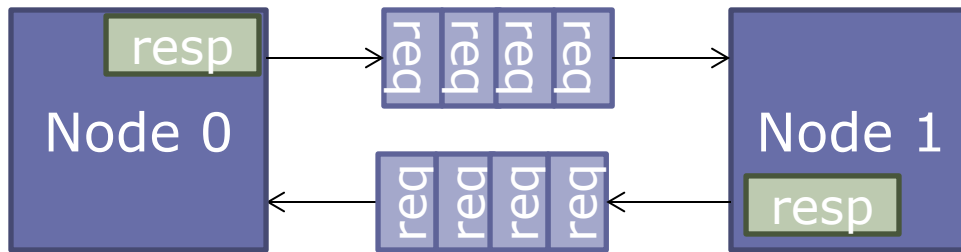

Example: Both nodes saturate all intermediate buffers with requests to each other, blocking responses from entering the network

- Solution: Separate *virtual networks*
 - Different sets of virtual channels and endpoint buffers
 - Same physical routers and links
- Most protocols require at least 2 virtual networks (for requests and replies), often >2 needed

Thank you!

*Next Lecture:
On-chip Networks*

Load-reserve & Store-conditional

Special register(s) to hold reservation flag and address, and the outcome of store-conditional

```
Load-reserve R, (a):  
  <flag, adr> ← <1, a>;  
  R ← M[a];
```

```
Store-conditional (a), R:  
  if <flag, adr> == <1, a>  
  then cancel other procs'  
        reservation on a;  
        M[a] ← <R>;  
        status ← succeed;  
  else status ← fail;
```

If the cache receives an invalidation to the address in the reserve register, the reserve bit is set to **0**

- Several processors may reserve 'a' simultaneously
- These instructions are like ordinary loads and stores with respect to the bus traffic

Load-Reserve/Store-Conditional

Swap implemented with Ld-Reserve/St-Conditional

```
# Swap(R1, mutex):
```

```
L: Ld-Reserve R2, (mutex)  
   St-Conditional (mutex), R1  
   if (status == fail) goto L  
   R1 <- R2
```

Performance:

Load-reserve & Store-conditional

The total number of coherence transactions is not necessarily reduced, but splitting an atomic instruction into load-reserve & store-conditional:

- *increases utilization* (and reduces processor stall time), especially in split-transaction buses and directories
- *reduces cache ping-pong effect* because processors trying to acquire a semaphore do not have to perform stores each time