

Complex Pipelining

Daniel Sanchez

Computer Science and Artificial Intelligence Laboratory
M.I.T.

Complex Pipelining: Motivation

Instruction pipelining becomes complex when we want high performance in the presence of

- Multi-cycle operations, for example:
 - Full or partially pipelined floating-point units, or
 - Long-latency operations, e.g., divides
- Variable-latency operations, for example:
 - Memory systems with variable access time
- Replicated function units, for example:
 - Multiple floating-point or memory units

CDC 6600

Seymour Cray, 1963



- A fast pipelined machine with 60-bit words
 - 128 Kword main memory capacity, 32 banks
- Ten functional units (parallel, unpipelined)
 - Floating Point: adder, 2 multipliers, divider
 - Integer: adder, 2 incrementers, ...
- Hardwired control
- **Dynamic scheduling of instructions using a scoreboard**
- Ten Peripheral Processors for Input/Output
 - A fast multi-threaded 12-bit integer ALU
- Very fast clock, 10 MHz (FP add in 4 clocks)
- >400,000 transistors, 750 sq. ft., 5 tons, 150 kW, new freon-based cooling technology
- Fastest machine in world for 5 years (until CDC 7600)
 - Over 100 sold (\$7-10M each)

CDC 6600: Datapath

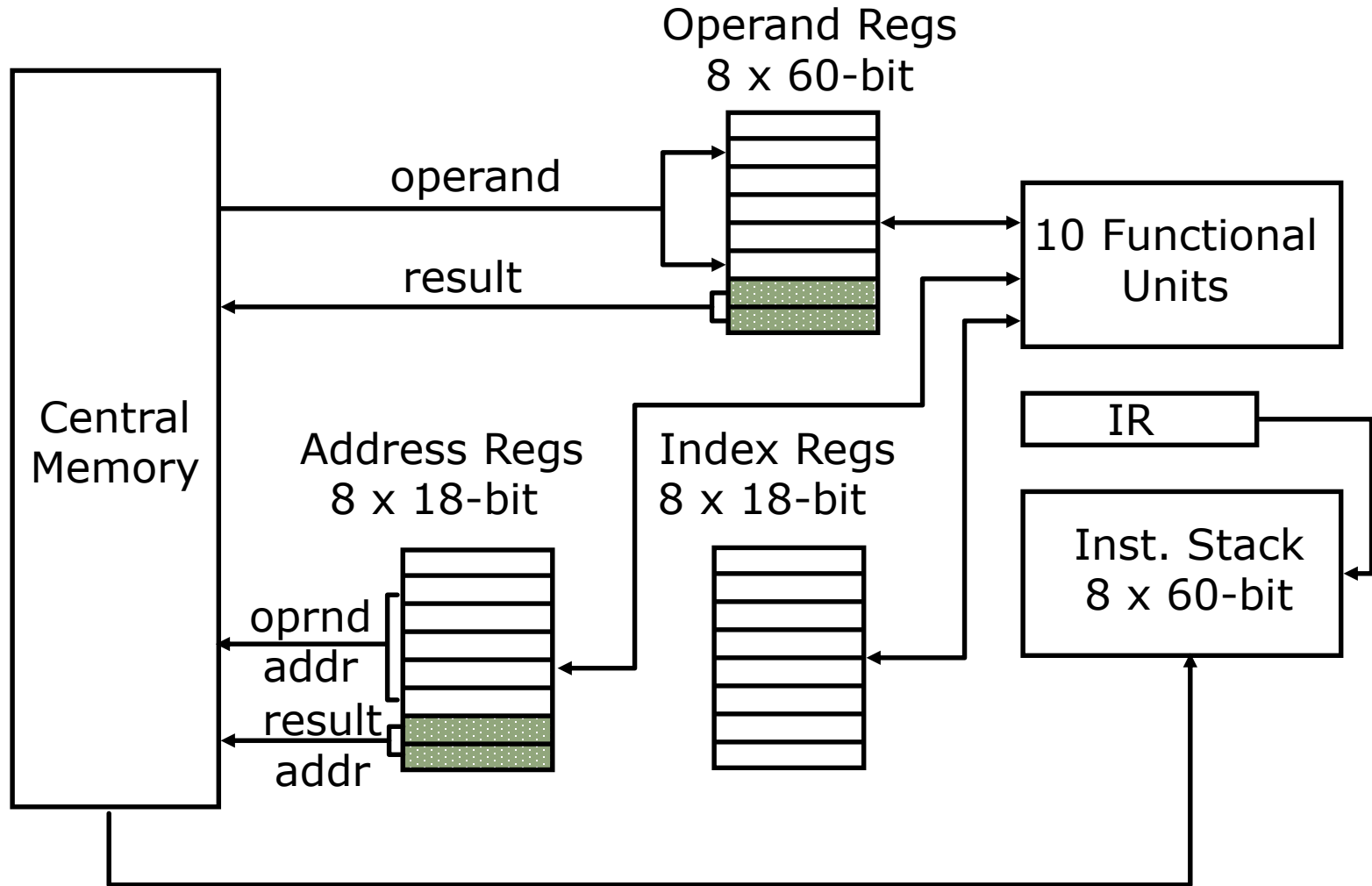

CDC 6600: A Load/Store Architecture

- Separate instructions to manipulate three types of reg.
 - 8 60-bit data registers (X)
 - 8 18-bit address registers (A)
 - 8 18-bit index registers (B)

- All arithmetic and logic instructions are reg-to-reg

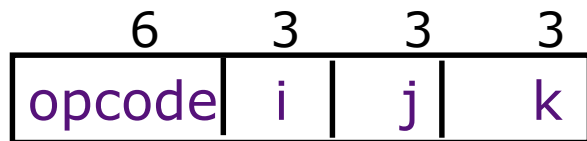

$$R_i \leftarrow (R_j) \text{ op } (R_k)$$

- Only Load and Store instructions refer to memory!



$$R_i \leftarrow M[(R_j) + \text{disp}]$$

- Touching address registers 1 to 5 initiates a load
 - 6 to 7 initiates a store
 - *very useful for vector operations*

CDC6600: Vector Addition

```
      B1 ← - n
loop: JZE  B1, exit
      A1 ← B1 + a1      load into X1
      A2 ← B1 + b1      load into X2
      X6 ← X1 + X2
      A6 ← B1 + c1      store X6
      B1 ← B1 + 1
      jump loop
```

A_i = address register

B_i = index register

X_i = data register

more on vector processing later...

We will present complex
pipelining issues more
abstractly ...

Floating Point ISA

Interaction between the Floating point datapath and the Integer datapath is determined largely by the ISA

MIPS ISA

- separate register files for FP and Integer instructions
the only interaction is via a set of move instructions (some ISAs don't even permit this)
- separate load/store for FPR's and GPR's but both use GPR's for address calculation
- separate conditions for branches
FP branches are defined in terms of condition codes

Floating Point Unit

Much more hardware than an integer unit

Single-cycle floating point unit is a bad idea - *why?*

- it is common to have several floating point units
- it is common to have different types of FPUs
Fadd, Fmul, Fdiv, ...
- an FPU may be pipelined, partially pipelined or not pipelined

To operate several FPUs concurrently the register file needs to have more read and write ports

Functional Unit Characteristics

*fully
pipelined*

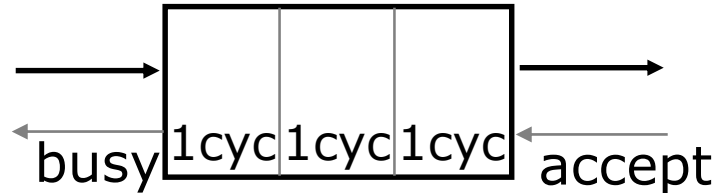

*partially
pipelined*

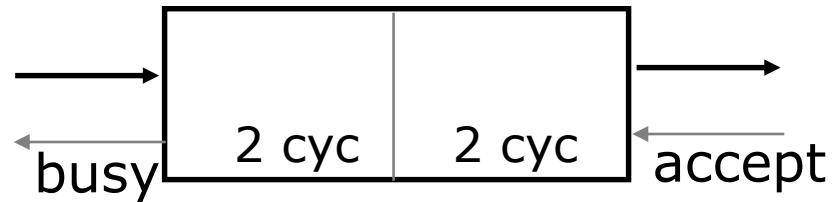

Functional units have internal pipeline registers

- ⇒ operands are latched when an instruction enters a functional unit
- ⇒ inputs to a functional unit (e.g., register file) can change during a long latency operation

Realistic Memory Systems

Latency of access to the main memory is usually much higher than one cycle and often unpredictable
Solving this problem is a central issue in computer architecture

Realistic Memory Systems

Latency of access to the main memory is usually much higher than one cycle and often unpredictable

Solving this problem is a central issue in computer architecture

Common approaches to improving memory performance

- separate instruction and data memory ports
⇒ *no self-modifying code*
- caches
single cycle except in case of a miss ⇒ stall
- interleaved memory
multiple memory accesses ⇒ bank conflicts
- split-phase memory operations
⇒ *out-of-order responses*

Complex Pipeline Structure

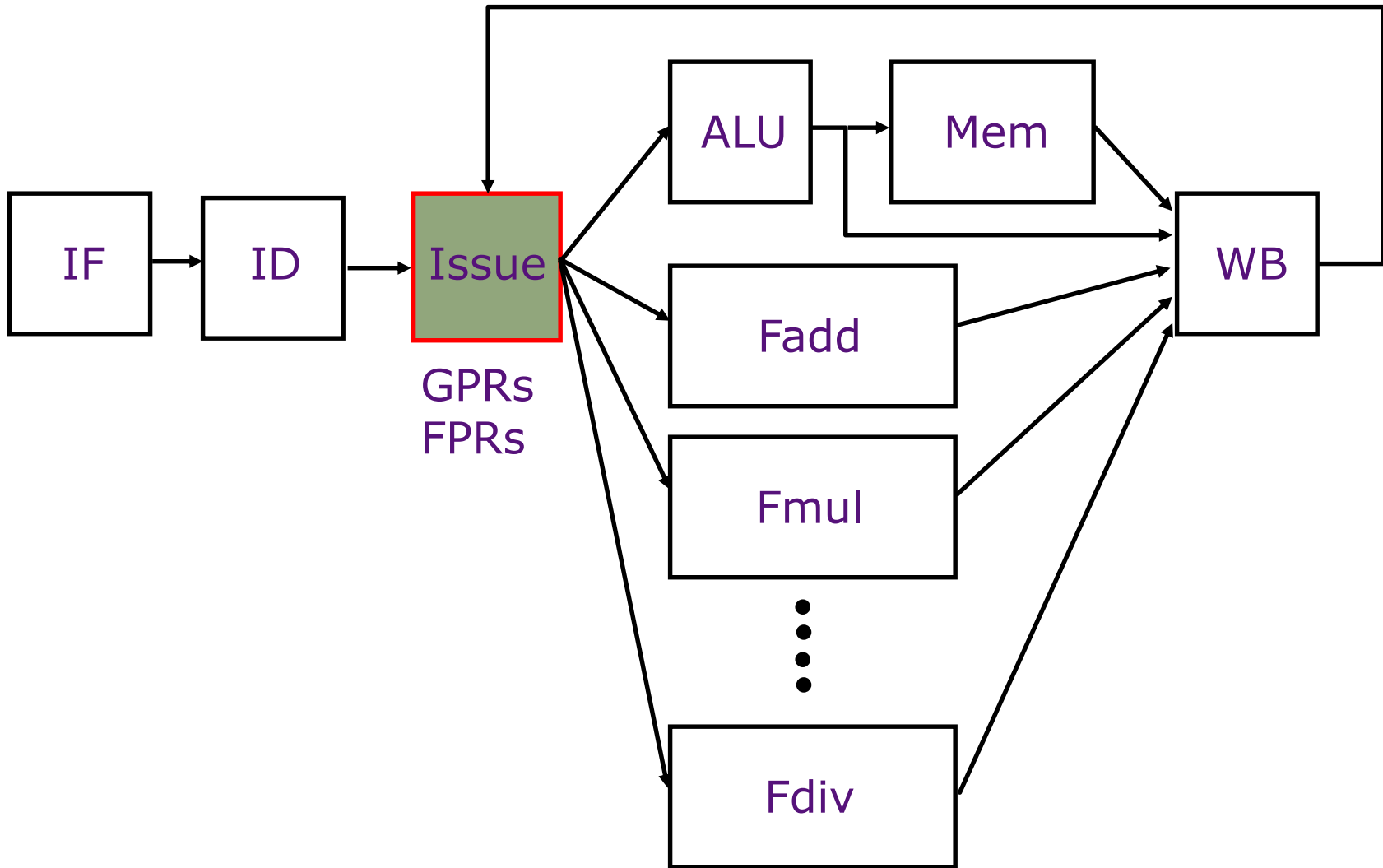

Complex Pipeline Control Issues

- Structural hazards at the execution stage if some FPU or memory unit is not pipelined and takes more than one cycle

Complex Pipeline Control Issues

- Structural hazards at the execution stage if some FPU or memory unit is not pipelined and takes more than one cycle
- Structural hazards at the write-back stage due to variable latencies of different function units

Complex Pipeline Control Issues

- Structural hazards at the execution stage if some FPU or memory unit is not pipelined and takes more than one cycle
- Structural hazards at the write-back stage due to variable latencies of different function units
- Out-of-order write hazards due to variable latencies of different function units

Complex Pipeline Control Issues

- Structural hazards at the execution stage if some FPU or memory unit is not pipelined and takes more than one cycle
- Structural hazards at the write-back stage due to variable latencies of different function units
- Out-of-order write hazards due to variable latencies of different function units
- How to handle exceptions?

Complex In-Order Pipeline

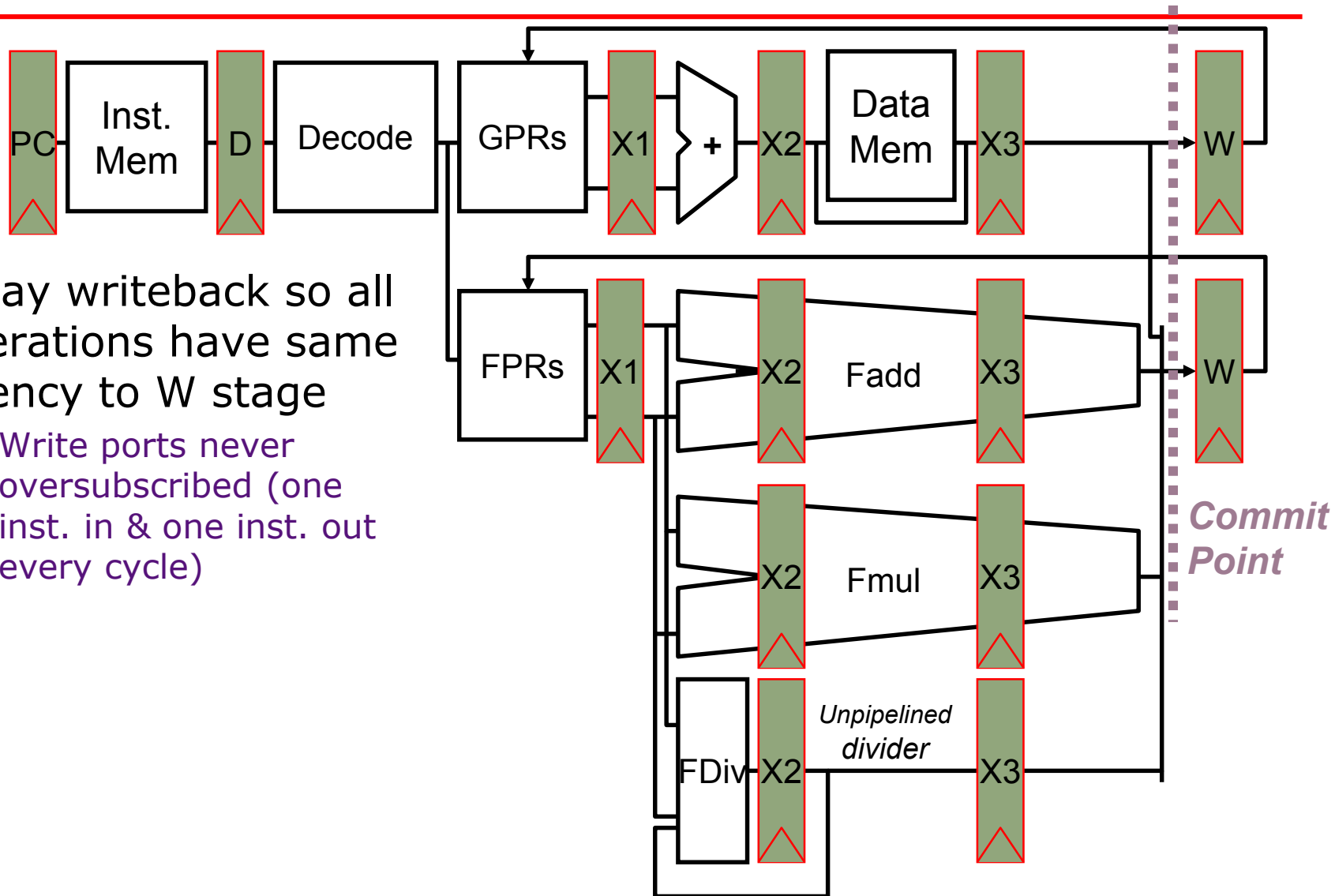

- Delay writeback so all operations have same latency to W stage
 - Write ports never oversubscribed (one inst. in & one inst. out every cycle)

Complex In-Order Pipeline

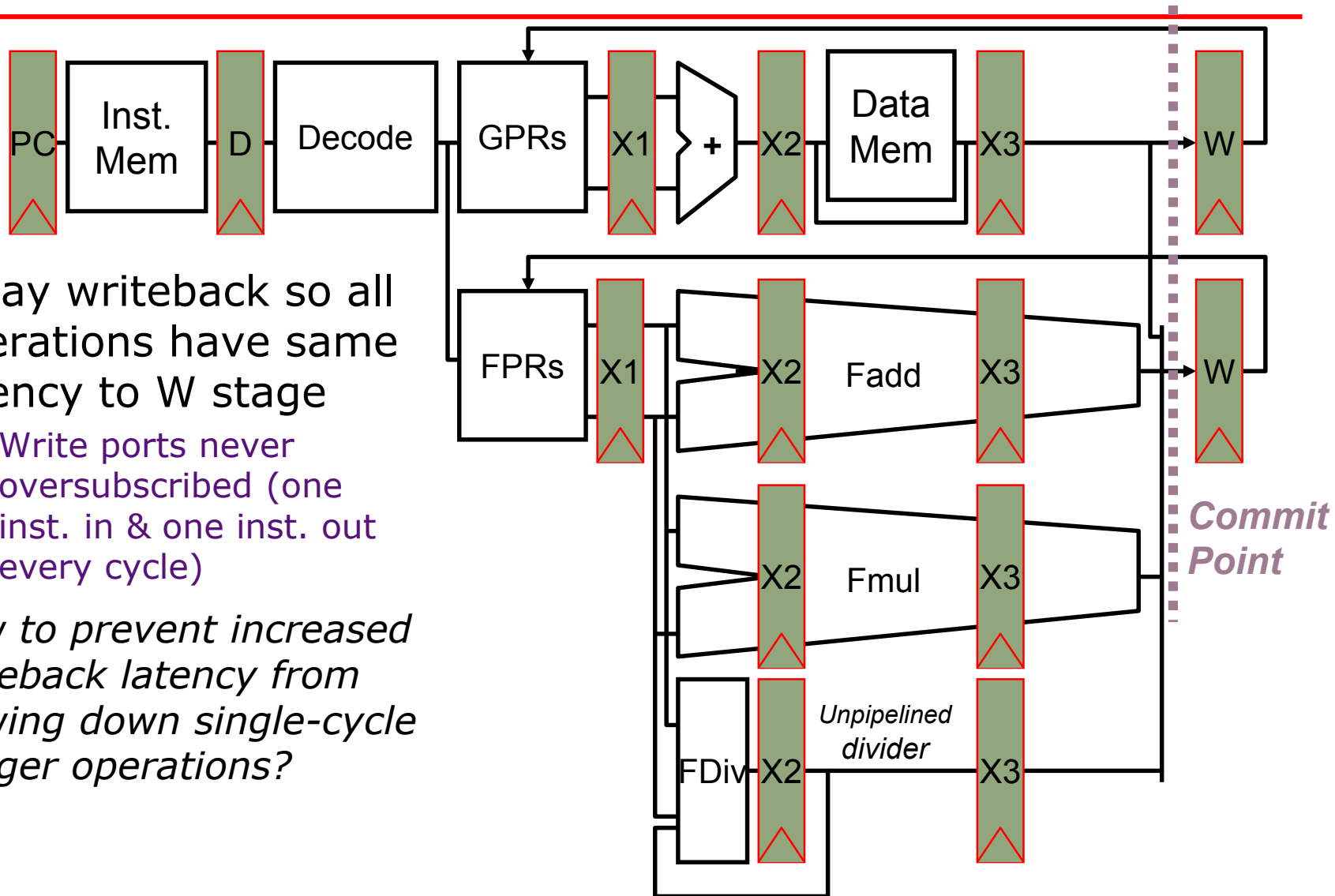

- Delay writeback so all operations have same latency to W stage
 - Write ports never oversubscribed (one inst. in & one inst. out every cycle)

How to prevent increased writeback latency from slowing down single-cycle integer operations?

Complex In-Order Pipeline

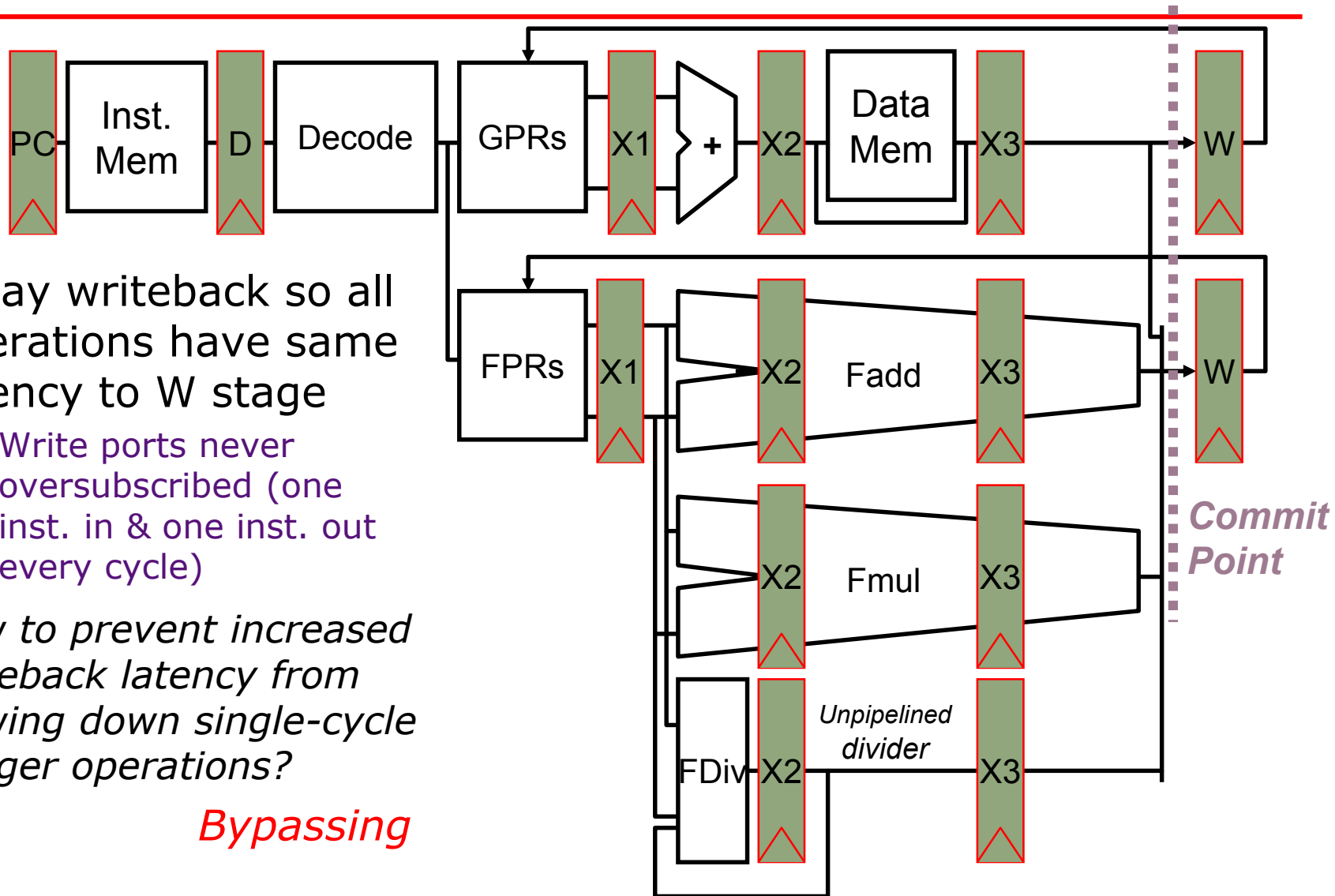

- Delay writeback so all operations have same latency to W stage
 - Write ports never oversubscribed (one inst. in & one inst. out every cycle)

How to prevent increased writeback latency from slowing down single-cycle integer operations?

Bypassing

Complex In-Order Pipeline

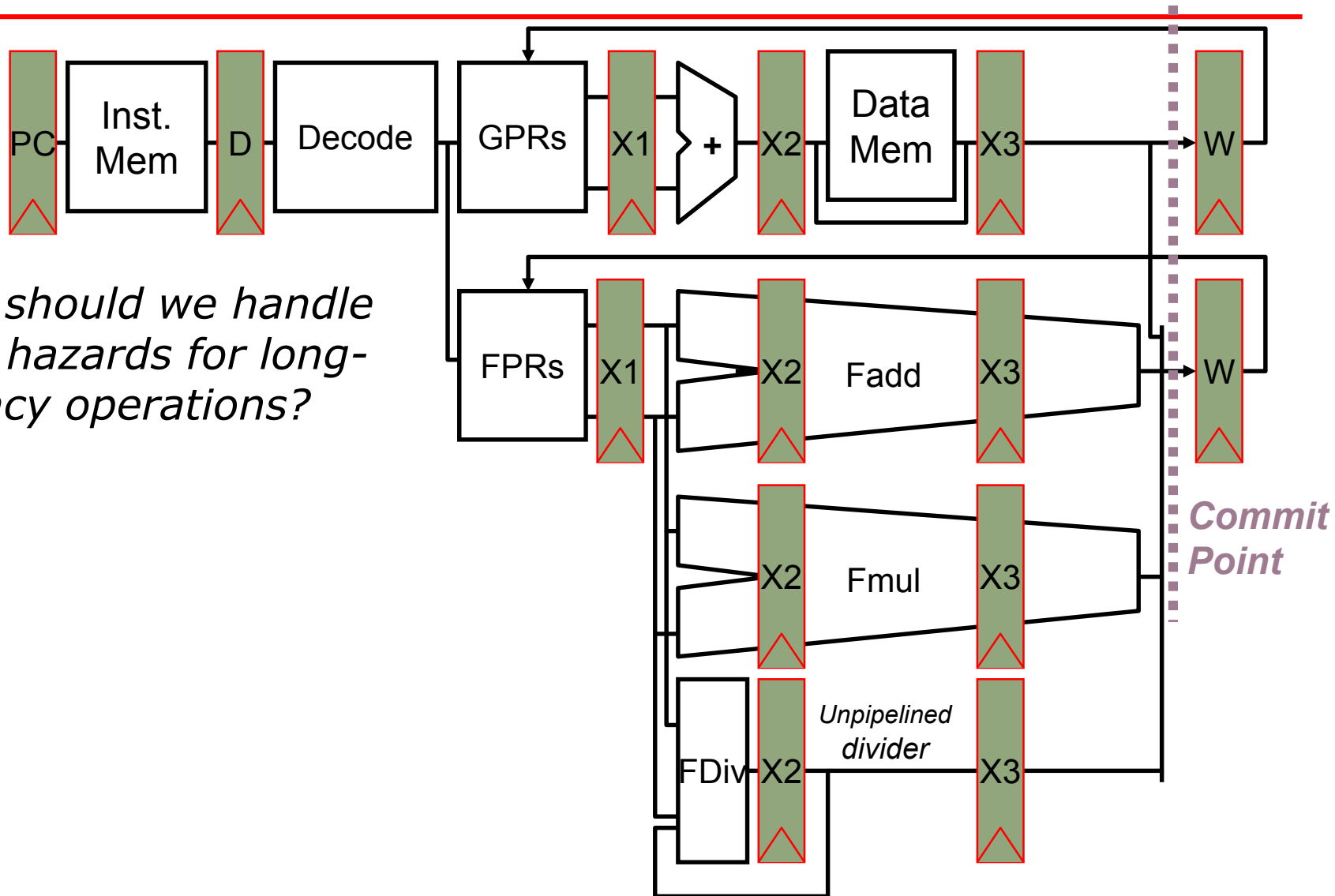

Complex In-Order Pipeline

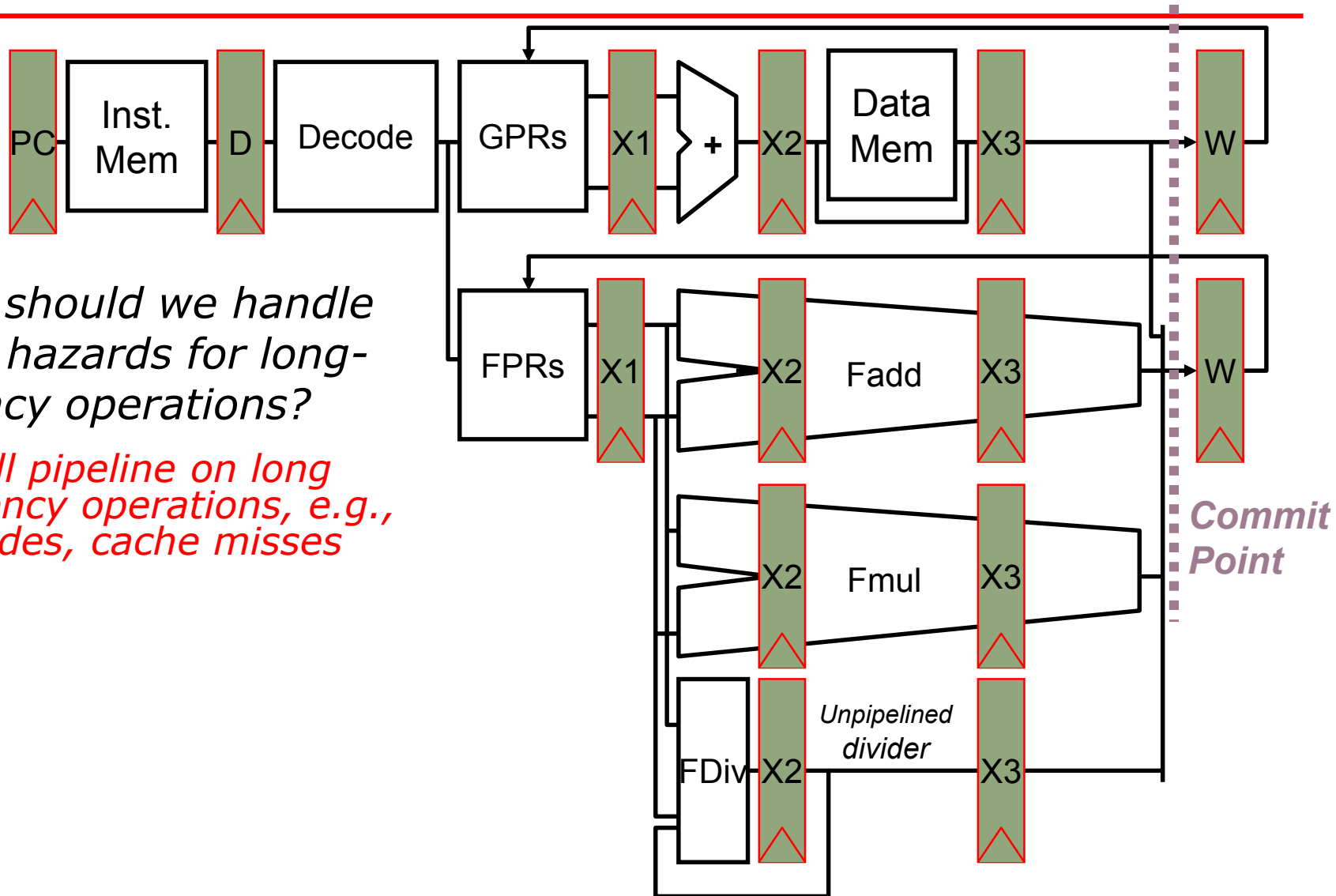

How should we handle data hazards for long-latency operations?

Stall pipeline on long latency operations, e.g., divides, cache misses

Complex In-Order Pipeline

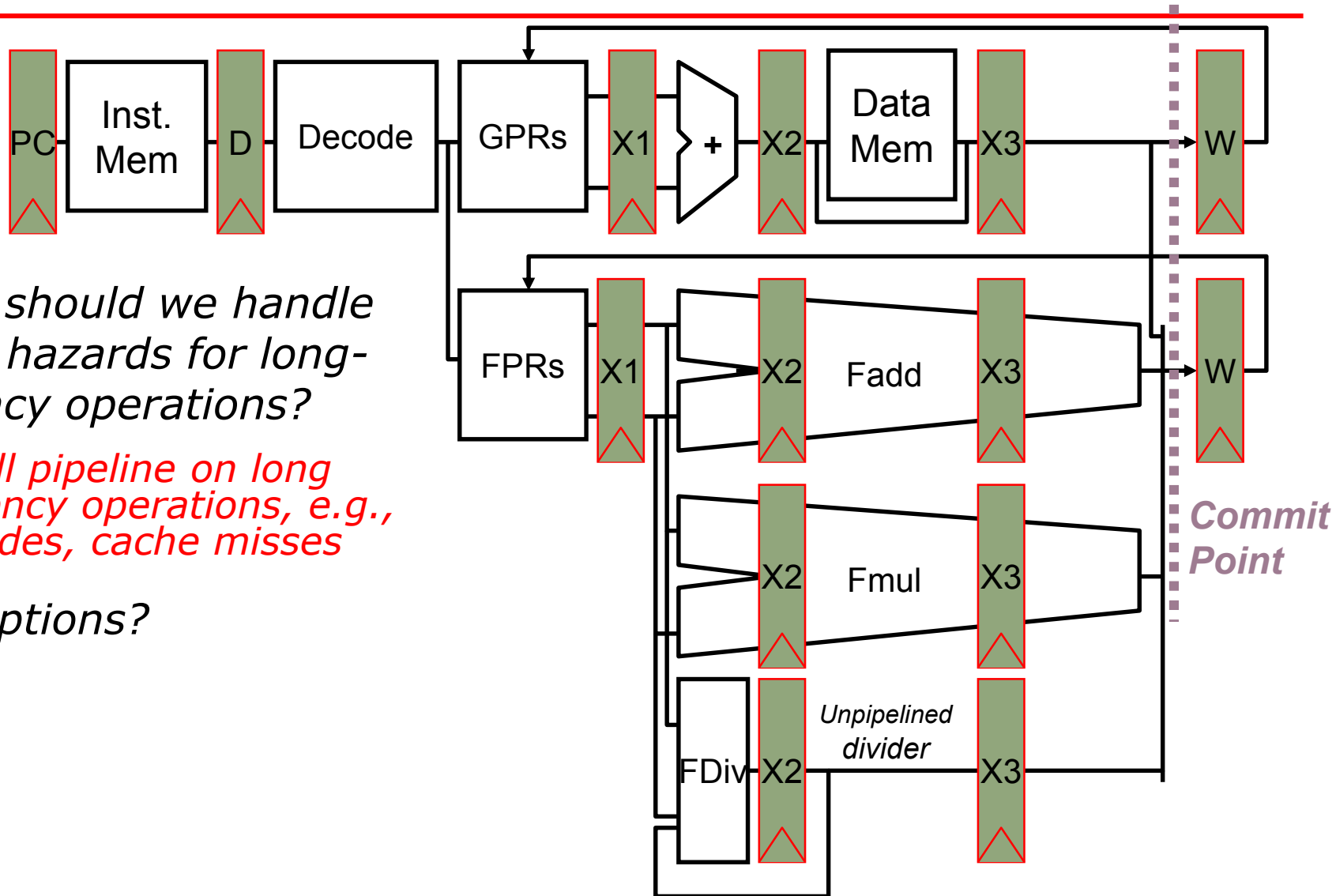

How should we handle data hazards for long-latency operations?

Stall pipeline on long latency operations, e.g., divides, cache misses

Exceptions?

Complex In-Order Pipeline

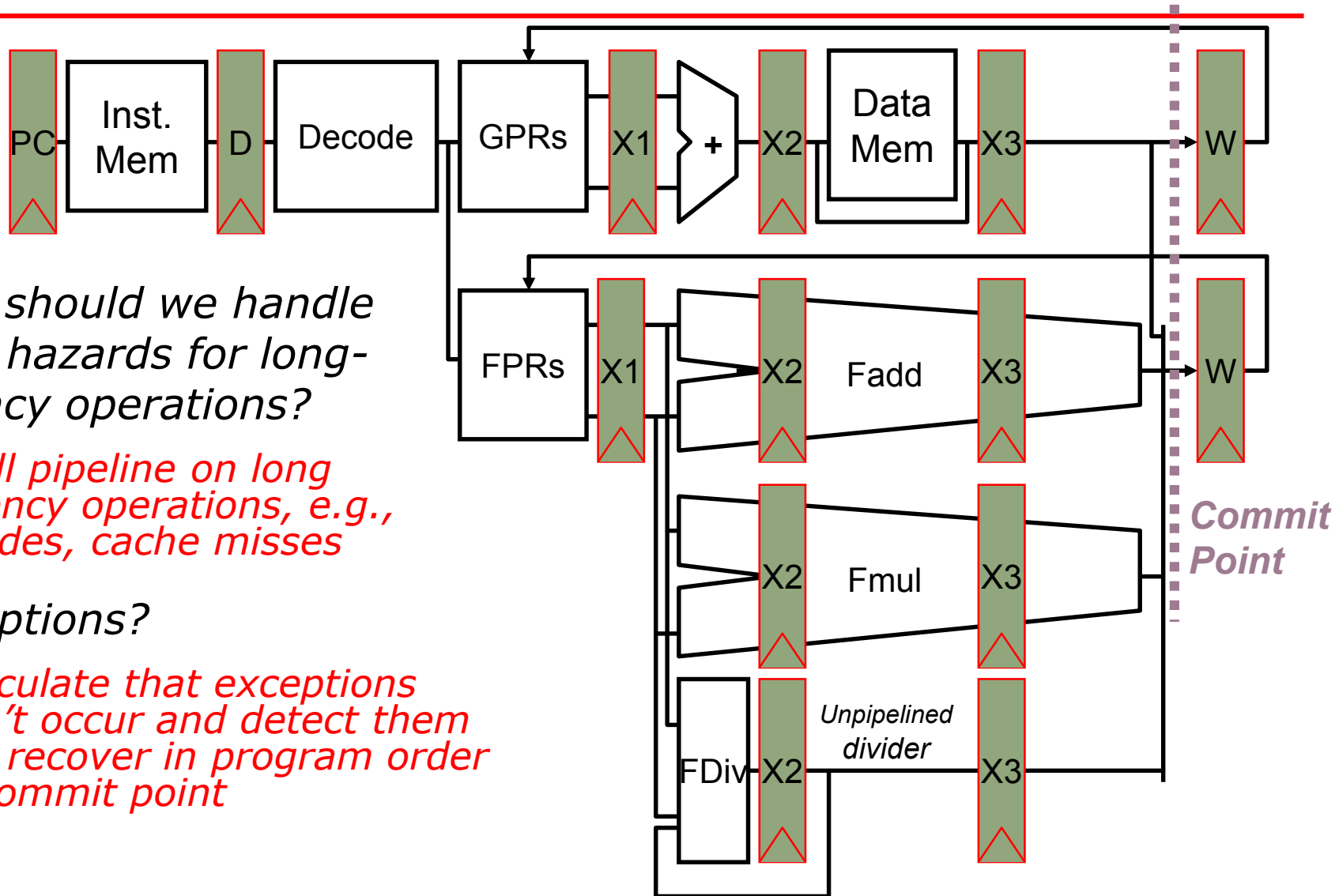

How should we handle data hazards for long-latency operations?

Stall pipeline on long latency operations, e.g., divides, cache misses

Exceptions?

Speculate that exceptions won't occur and detect them and recover in program order at commit point

Superscalar In-Order Pipeline

- Fetch two instructions per cycle; issue both simultaneously *if* one is integer/memory and other is floating-point

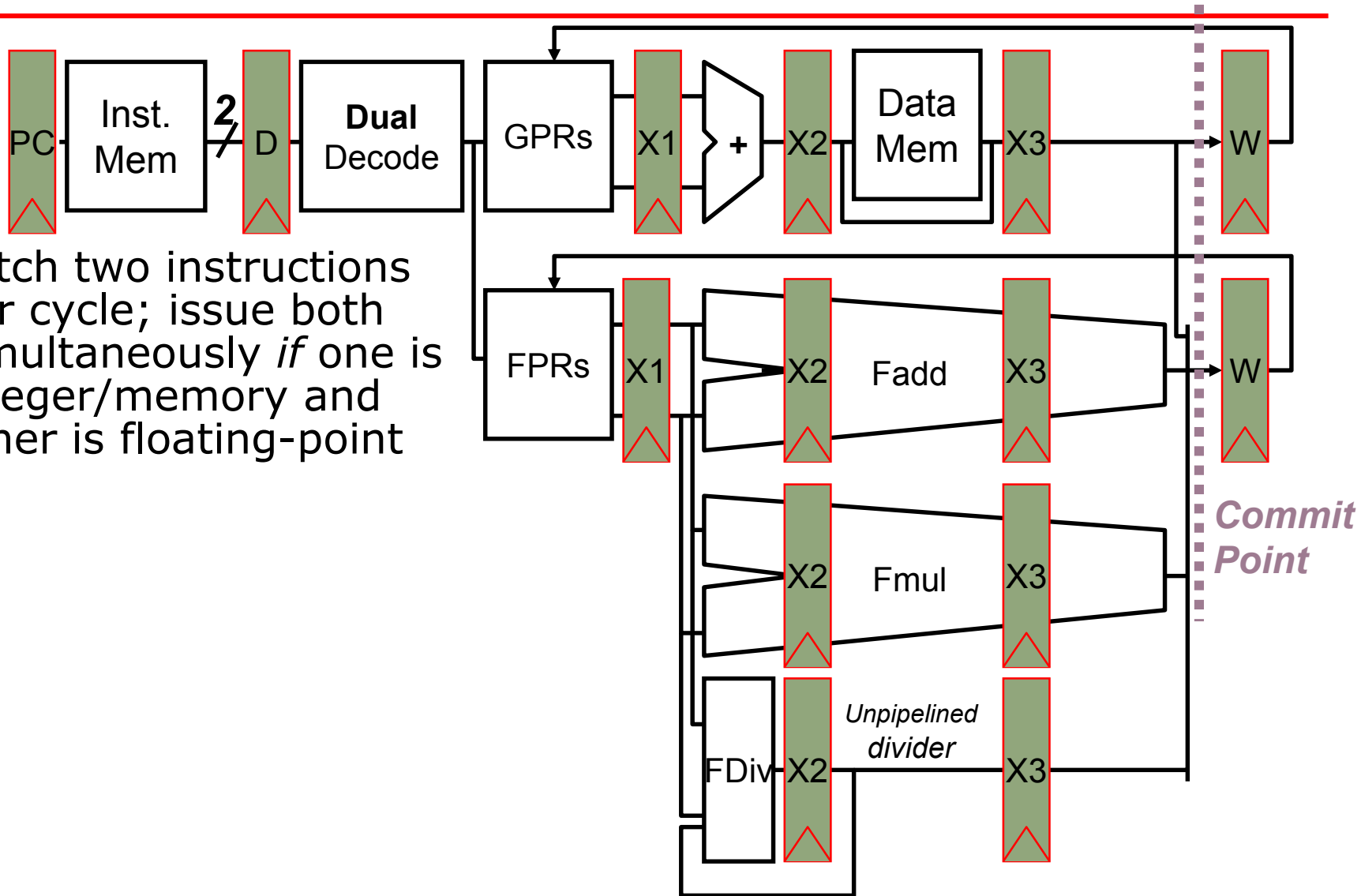

Superscalar In-Order Pipeline

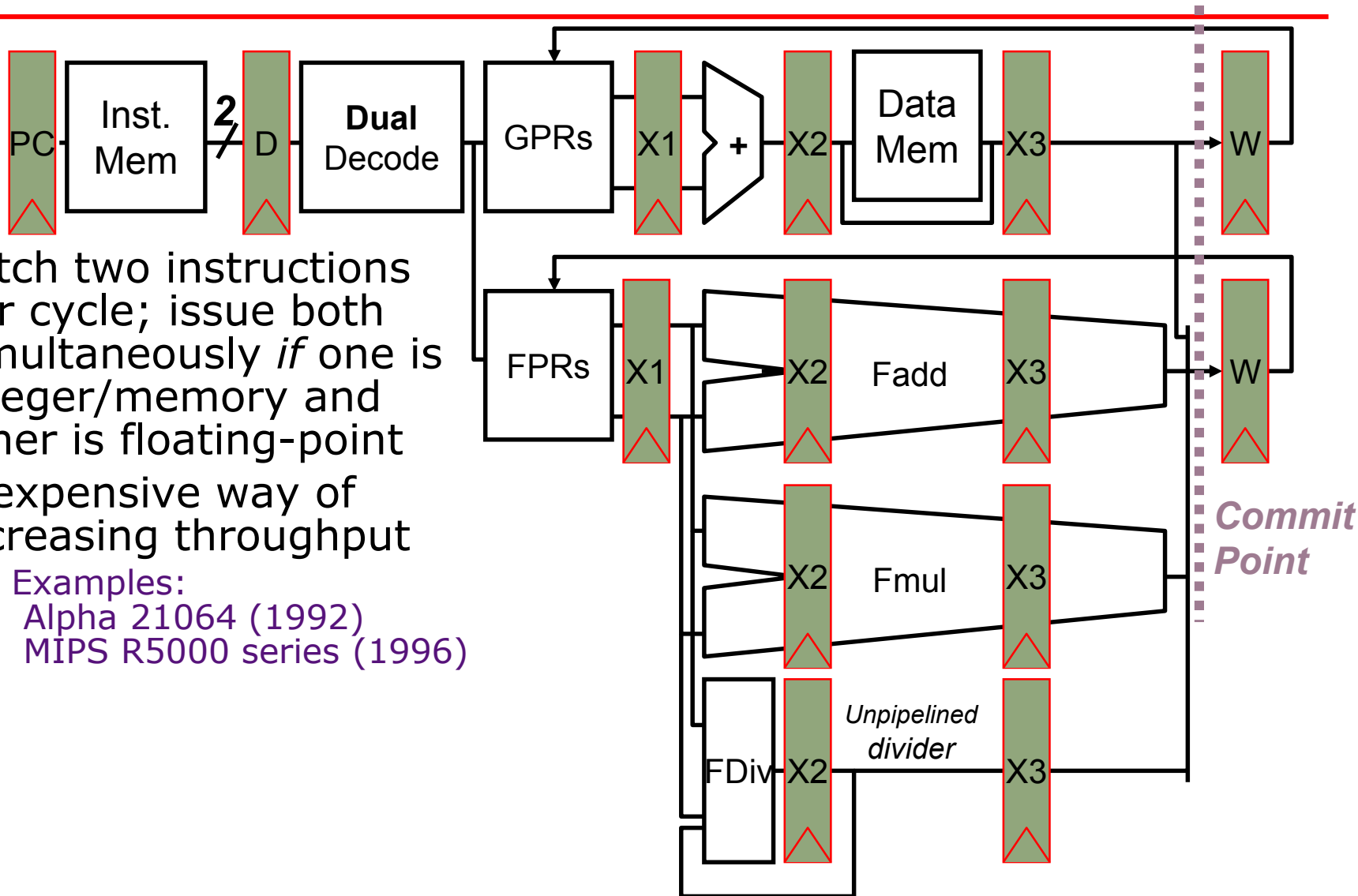

- Fetch two instructions per cycle; issue both simultaneously *if* one is integer/memory and other is floating-point
- Inexpensive way of increasing throughput
 - Examples:
 - Alpha 21064 (1992)
 - MIPS R5000 series (1996)

Superscalar In-Order Pipeline

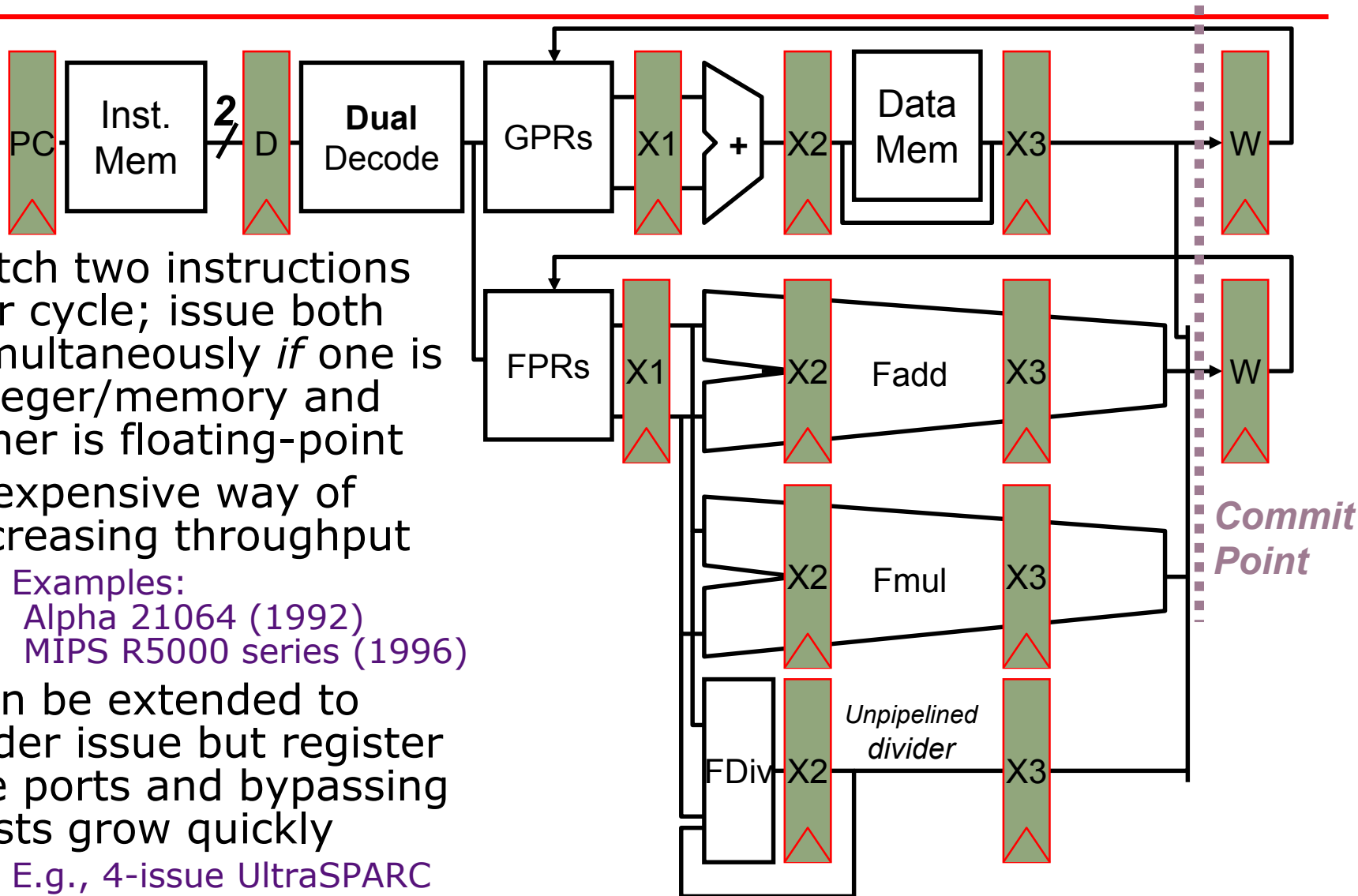

- Fetch two instructions per cycle; issue both simultaneously *if* one is integer/memory and other is floating-point
- Inexpensive way of increasing throughput
 - Examples:
 - Alpha 21064 (1992)
 - MIPS R5000 series (1996)
- Can be extended to wider issue but register file ports and bypassing costs grow quickly
 - E.g., 4-issue UltraSPARC

Dependence Analysis

Needed to Exploit Instruction-level Parallelism

Types of Data Hazards

Consider executing a sequence of

$$r_k \leftarrow (r_i) \text{ op } (r_j)$$

type of instructions

Types of Data Hazards

Consider executing a sequence of

$$r_k \leftarrow (r_i) \text{ op } (r_j)$$

type of instructions

Data-dependence

$$r_3 \leftarrow (r_1) \text{ op } (r_2)$$

$$r_5 \leftarrow (r_3) \text{ op } (r_4)$$

Read-after-Write
(RAW) hazard

Types of Data Hazards

Consider executing a sequence of

$$r_k \leftarrow (r_i) \text{ op } (r_j)$$

type of instructions

Data-dependence

$$r_3 \leftarrow (r_1) \text{ op } (r_2)$$

$$r_5 \leftarrow (r_3) \text{ op } (r_4)$$

Read-after-Write
(RAW) hazard

Types of Data Hazards

Consider executing a sequence of

$$r_k \leftarrow (r_i) \text{ op } (r_j)$$

type of instructions

Data-dependence

$$\begin{array}{l} r_3 \leftarrow (r_1) \text{ op } (r_2) \\ r_5 \leftarrow (r_3) \text{ op } (r_4) \end{array}$$

Read-after-Write
(RAW) hazard

Anti-dependence

$$\begin{array}{l} r_3 \leftarrow (r_1) \text{ op } (r_2) \\ r_1 \leftarrow (r_4) \text{ op } (r_5) \end{array}$$

Write-after-Read
(WAR) hazard

Types of Data Hazards

Consider executing a sequence of

$$r_k \leftarrow (r_i) \text{ op } (r_j)$$

type of instructions

Data-dependence

$$\begin{array}{l} r_3 \leftarrow (r_1) \text{ op } (r_2) \\ r_5 \leftarrow (r_3) \text{ op } (r_4) \end{array}$$

Read-after-Write
(RAW) hazard

Anti-dependence

$$\begin{array}{l} r_3 \leftarrow (r_1) \text{ op } (r_2) \\ r_1 \leftarrow (r_4) \text{ op } (r_5) \end{array}$$

Write-after-Read
(WAR) hazard

Types of Data Hazards

Consider executing a sequence of

$$r_k \leftarrow (r_i) \text{ op } (r_j)$$

type of instructions

Data-dependence

$$\begin{array}{l} r_3 \leftarrow (r_1) \text{ op } (r_2) \\ r_5 \leftarrow (r_3) \text{ op } (r_4) \end{array}$$

Read-after-Write
(RAW) hazard

Anti-dependence

$$\begin{array}{l} r_3 \leftarrow (r_1) \text{ op } (r_2) \\ r_1 \leftarrow (r_4) \text{ op } (r_5) \end{array}$$

Write-after-Read
(WAR) hazard

Output-dependence

$$\begin{array}{l} r_3 \leftarrow (r_1) \text{ op } (r_2) \\ r_3 \leftarrow (r_6) \text{ op } (r_7) \end{array}$$

Write-after-Write
(WAW) hazard

Types of Data Hazards

Consider executing a sequence of

$$r_k \leftarrow (r_i) \text{ op } (r_j)$$

type of instructions

Data-dependence

$$\begin{array}{l} r_3 \leftarrow (r_1) \text{ op } (r_2) \\ r_5 \leftarrow (r_3) \text{ op } (r_4) \end{array}$$



Read-after-Write
(RAW) hazard

Anti-dependence

$$\begin{array}{l} r_3 \leftarrow (r_1) \text{ op } (r_2) \\ r_1 \leftarrow (r_4) \text{ op } (r_5) \end{array}$$

Write-after-Read
(WAR) hazard

Output-dependence

$$\begin{array}{l} r_3 \leftarrow (r_1) \text{ op } (r_2) \\ r_3 \leftarrow (r_6) \text{ op } (r_7) \end{array}$$

Write-after-Write
(WAW) hazard

Detecting Data Hazards

Range and Domain of instruction i

$R(i)$ = Registers (or other storage) modified by instruction i

$D(i)$ = Registers (or other storage) read by instruction i

Detecting Data Hazards

Range and Domain of instruction i

$R(i)$ = Registers (or other storage) modified by instruction i

$D(i)$ = Registers (or other storage) read by instruction i

Suppose instruction j follows instruction i in the program order. Executing instruction j before the effect of instruction i has taken place can cause a

RAW hazard if $R(i) \cap D(j) \neq \emptyset$

WAR hazard if $D(i) \cap R(j) \neq \emptyset$

WAW hazard if $R(i) \cap R(j) \neq \emptyset$

Register vs. Memory Data Dependences

- Data hazards due to register operands can be determined at the decode stage *but*
- Data hazards due to memory operands can be determined only after computing the effective address

store $M[(r1) + disp1] \leftarrow (r2)$
load $r3 \leftarrow M[(r4) + disp2]$

Does $(r1) + disp1 == (r4) + disp2$?

Data Hazards: An Example

I_1	DIVD	f6,	f6,	f4
I_2	LD	f2,	45(r3)	
I_3	MULTD	f0,	f2,	f4
I_4	DIVD	f8,	f6,	f2
I_5	SUBD	f10,	f0,	f6
I_6	ADDD	f6,	f8,	f2

Data Hazards: An Example

I_1	DIVD	f6,	f6,	f4
I_2	LD	f2,	45(r3)	
I_3	MULTD	f0,	f2,	f4
I_4	DIVD	f8,	f6,	f2
I_5	SUBD	f10,	f0,	f6
I_6	ADDD	f6,	f8,	f2

RAW Hazards

Data Hazards: An Example

I_1	DIVD	f6,	f6,	f4
I_2	LD	f2,	45(r3)	
I_3	MULTD	f0,	f2,	f4
I_4	DIVD	f8,	f6,	f2
I_5	SUBD	f10,	f0,	f6
I_6	ADDD	f6,	f8,	f2

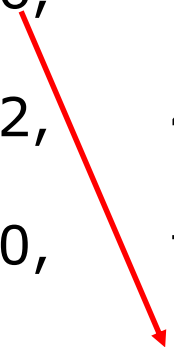

RAW Hazards

Data Hazards: An Example

I_1	DIVD	f6,	f6,	f4
I_2	LD	f2,	45(r3)	
I_3	MULTD	f0,	f2,	f4
I_4	DIVD	f8,	f6,	f2
I_5	SUBD	f10,	f0,	f6
I_6	ADDD	f6,	f8,	f2

RAW Hazards

Data Hazards: An Example

I_1	DIVD	f6,	f6,	f4
I_2	LD	f2,	45(r3)	
I_3	MULTD	f0,	f2,	f4
I_4	DIVD	f8,	f6,	f2
I_5	SUBD	f10,	f0,	f6
I_6	ADDD	f6,	f8,	f2

RAW Hazards

Data Hazards: An Example

I_1	DIVD	f6,	f6,	f4
I_2	LD	f2,	45(r3)	
I_3	MULTD	f0,	f2,	f4
I_4	DIVD	f8,	f6,	f2
I_5	SUBD	f10,	f0,	f6
I_6	ADDD	f6,	f8,	f2

RAW Hazards

Data Hazards: An Example

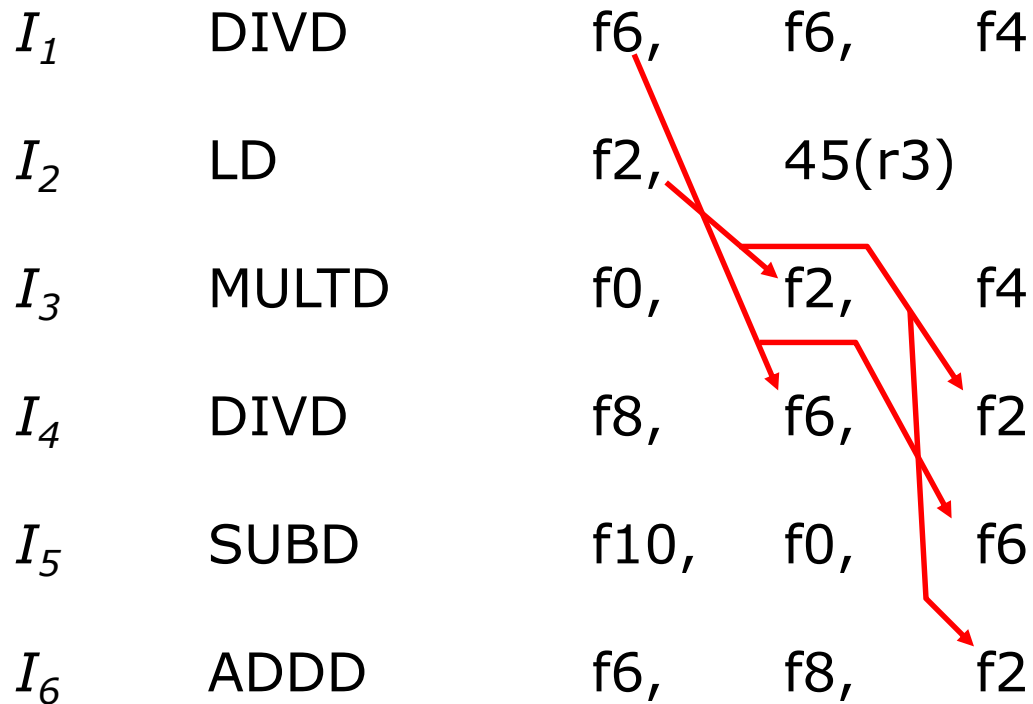

RAW Hazards

Data Hazards: An Example

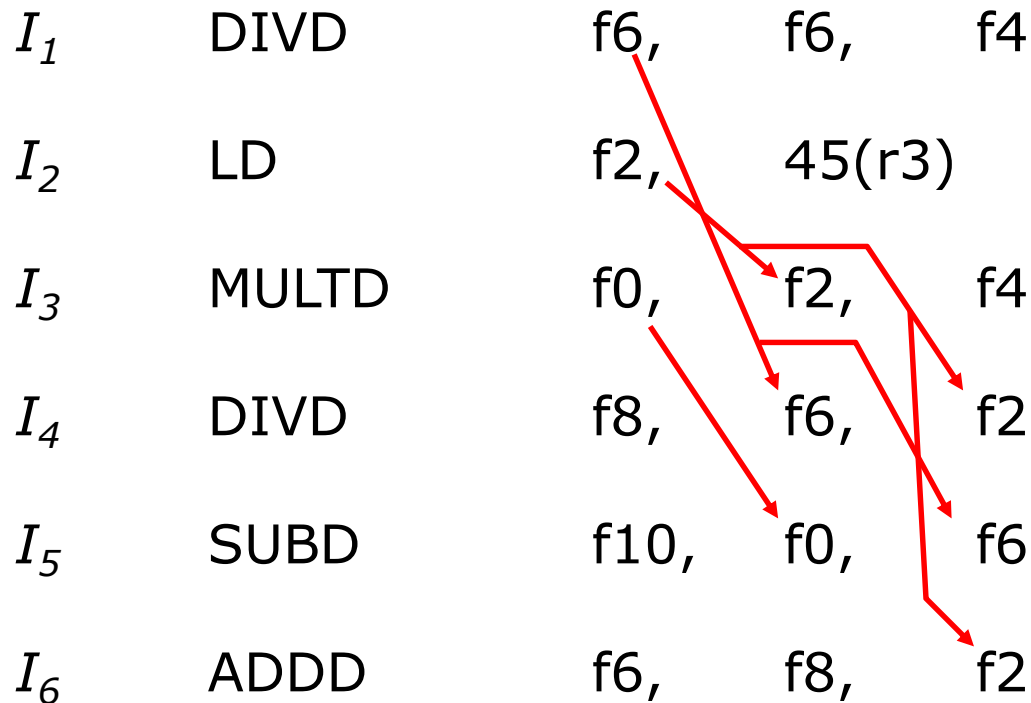

RAW Hazards

Data Hazards: An Example

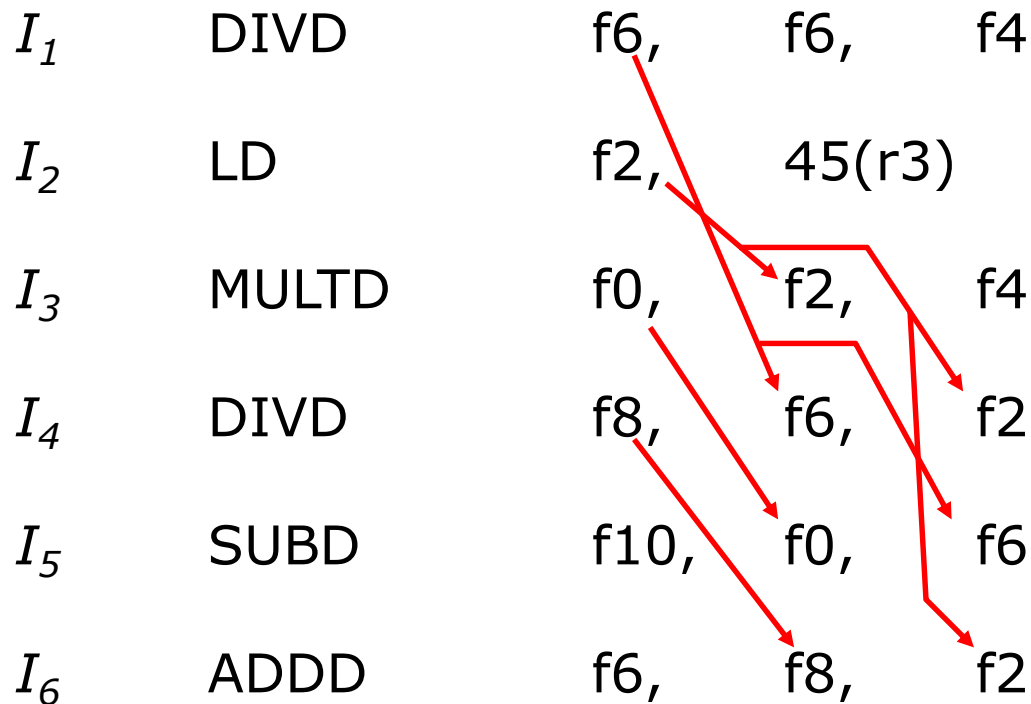

RAW Hazards

Data Hazards: An Example

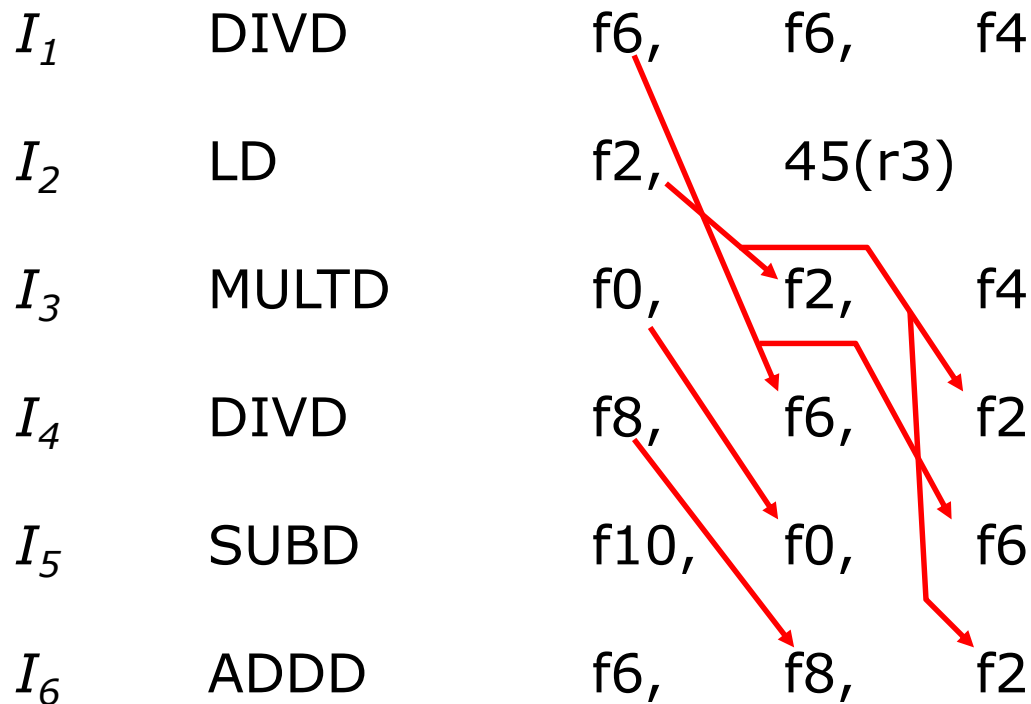

RAW Hazards

WAR Hazards

Data Hazards: An Example

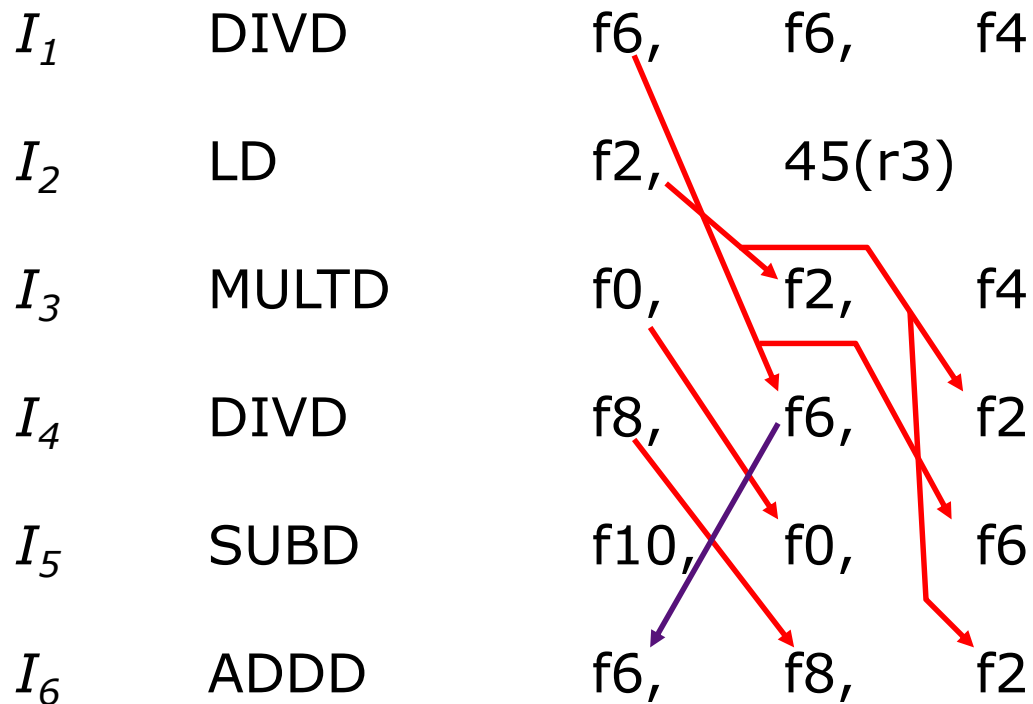

RAW Hazards

WAR Hazards

Data Hazards: An Example

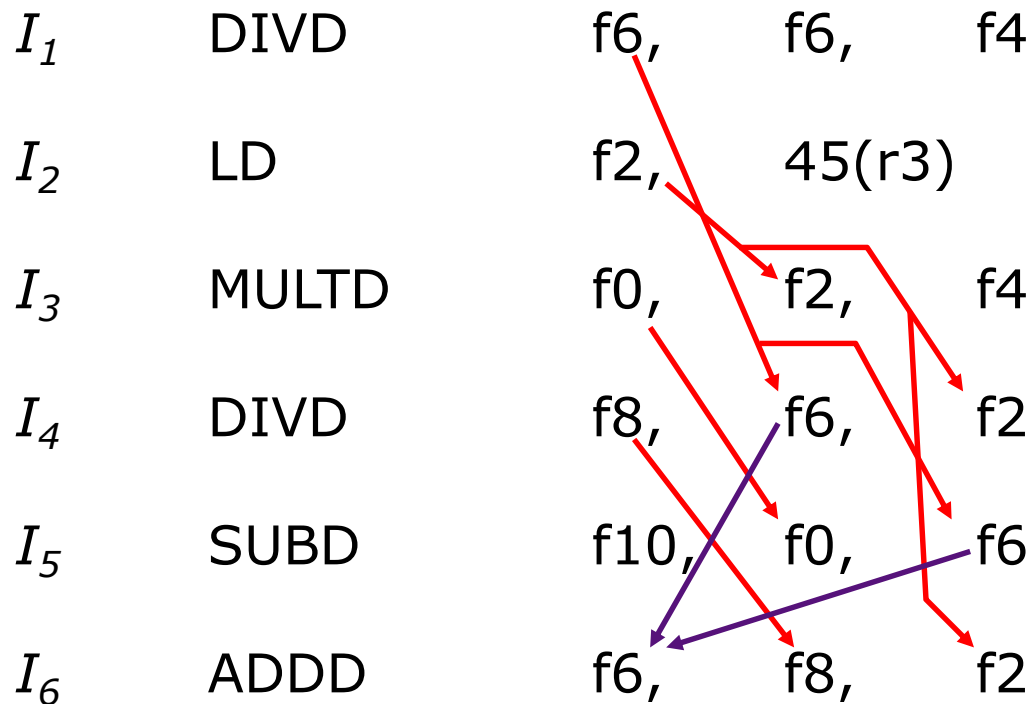

RAW Hazards

WAR Hazards

Data Hazards: An Example

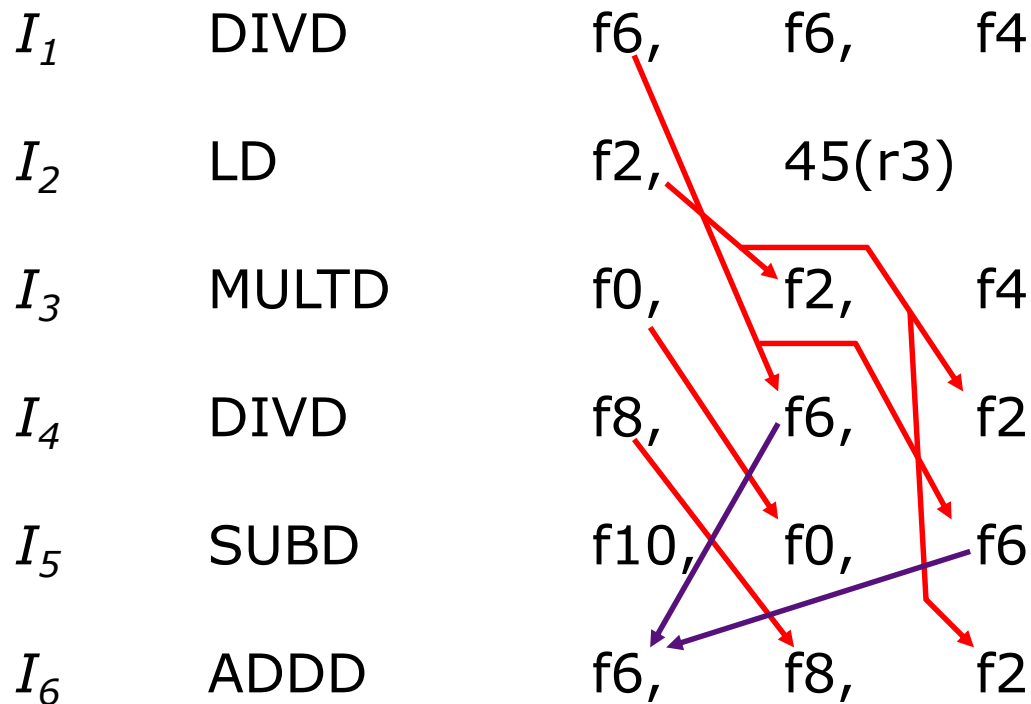

RAW Hazards

WAR Hazards

WAW Hazards

Data Hazards: An Example

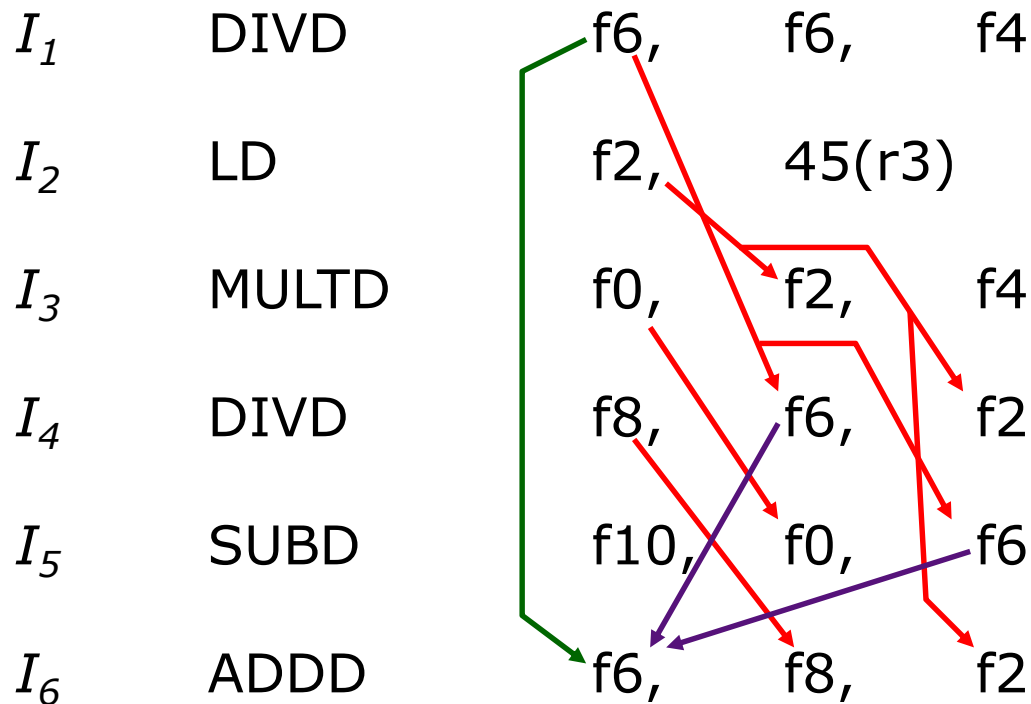

RAW Hazards

WAR Hazards

WAW Hazards

Instruction Scheduling

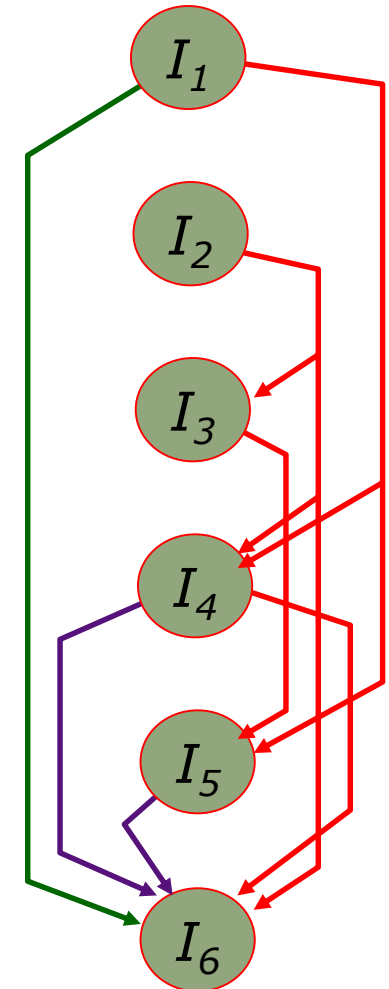
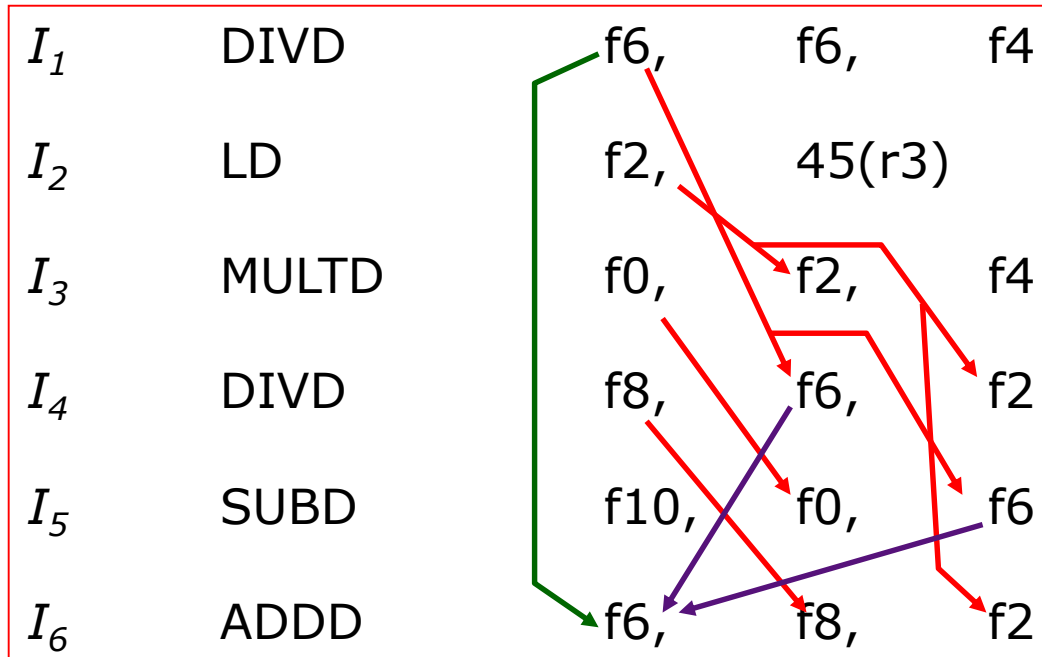

Instruction Scheduling

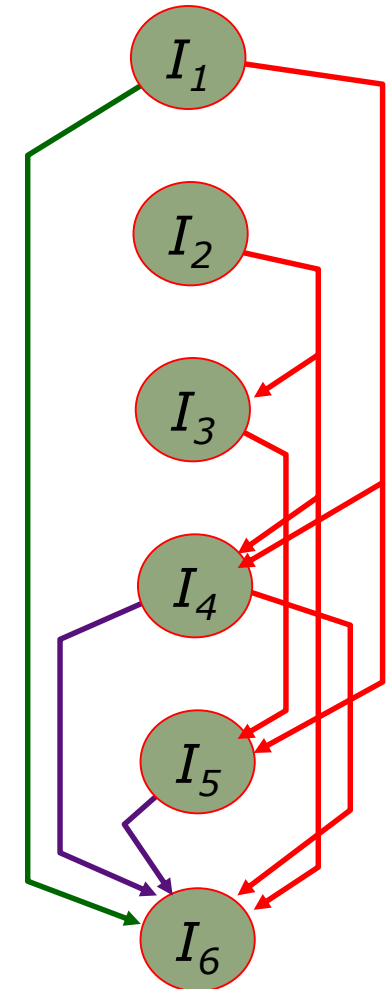
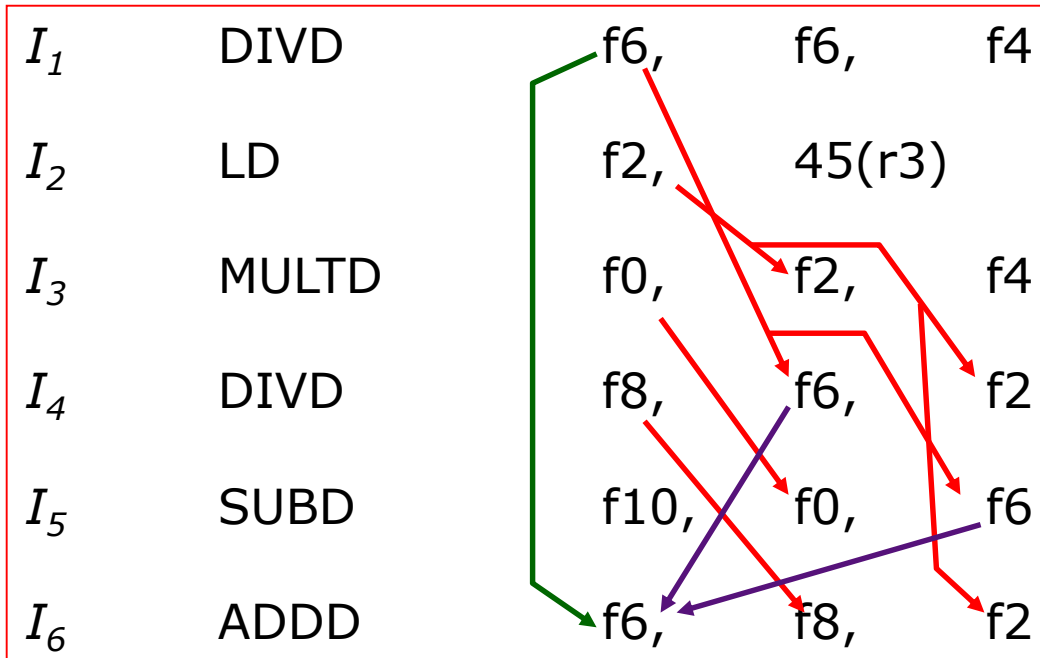

Valid orderings:

in-order

I_1

I_2

I_3

I_4

I_5

I_6

out-of-order

out-of-order

Instruction Scheduling

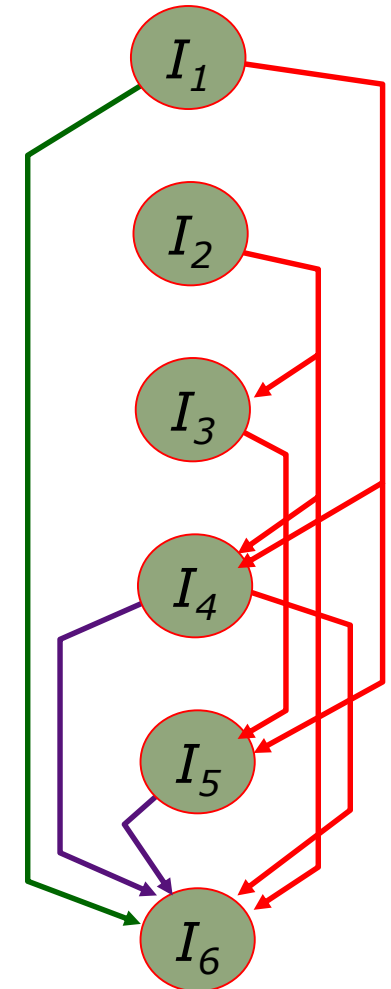
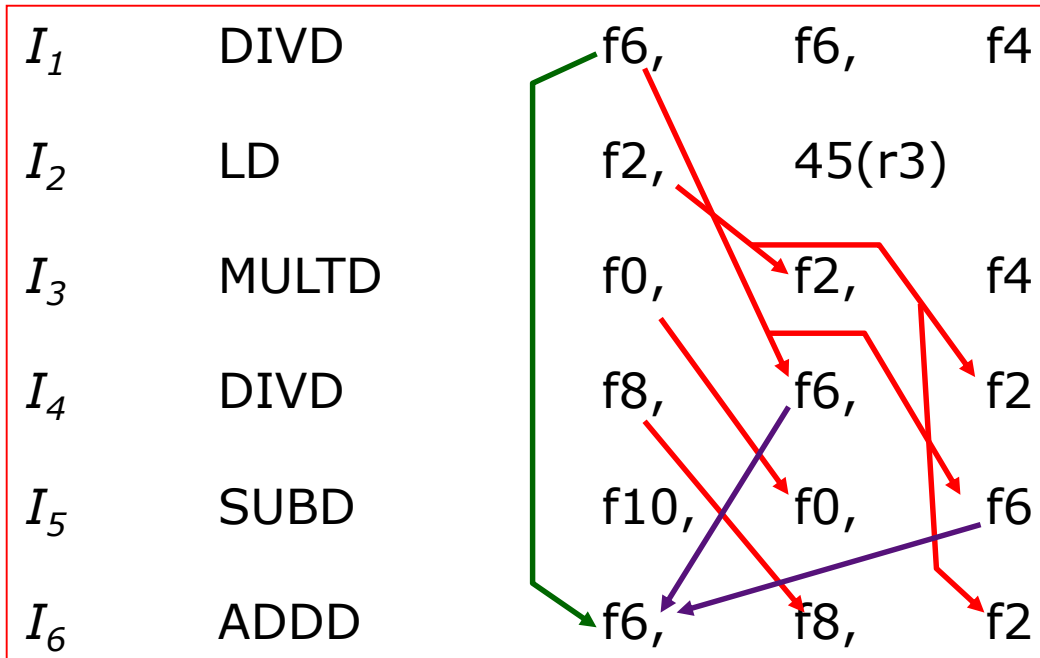

Valid orderings:

in-order I_1 I_2 I_3 I_4 I_5 I_6

out-of-order I_2 I_1 I_3 I_4 I_5 I_6

out-of-order

Instruction Scheduling

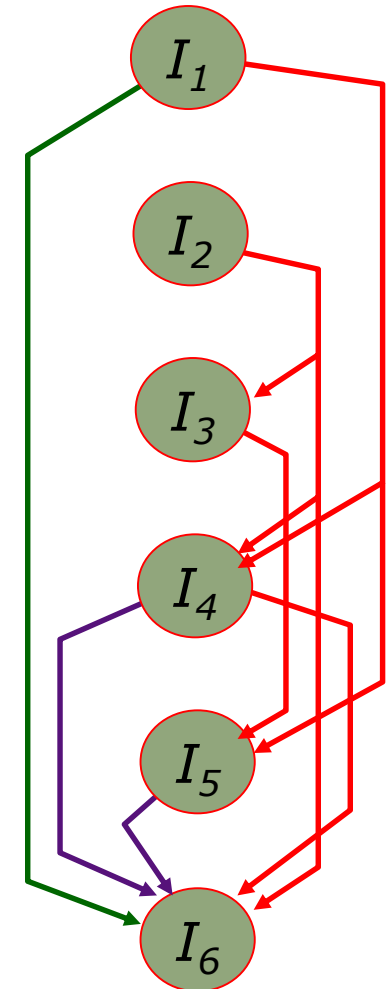
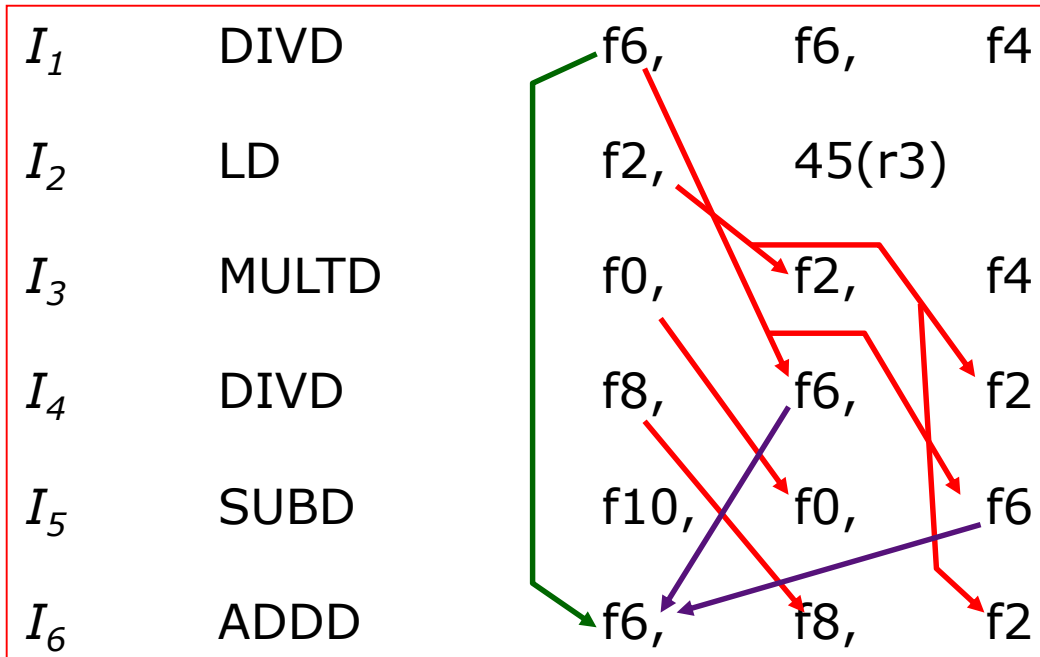

Valid orderings:

<i>in-order</i>	I_1	I_2	I_3	I_4	I_5	I_6
<i>out-of-order</i>	I_2	I_1	I_3	I_4	I_5	I_6
<i>out-of-order</i>	I_1	I_2	I_3	I_5	I_4	I_6

Scoreboard: A Hardware Data Structure to Detect Hazards Dynamically

Complex Pipeline

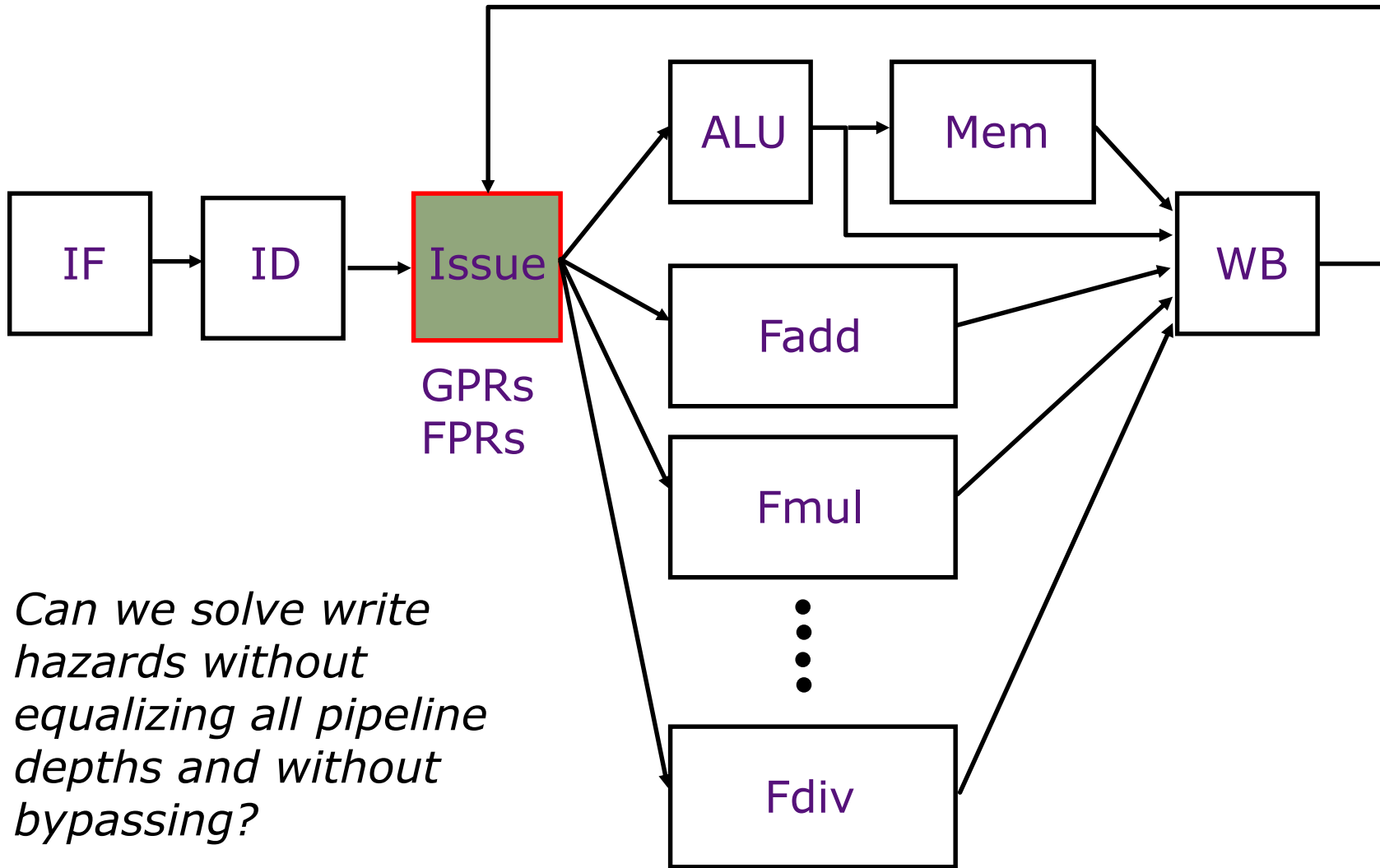

Can we solve write hazards without equalizing all pipeline depths and without bypassing?

When is it Safe to Issue an Instruction?

- Approach: Stall issue until sure that issuing will cause no dependence problems...
- Suppose a data structure keeps track of all the instructions in all the functional units
- The following checks need to be made before the Issue stage can dispatch an instruction
 - Is the required function unit available?
 - Is the input data available? \Rightarrow RAW?
 - Is it safe to write the destination? \Rightarrow WAR? WAW?
 - Is there a structural conflict at the WB stage?

A Data Structure for Correct Issues

Keeps track of the status of Functional Units

<i>Name</i>	<i>Busy</i>	<i>Op</i>	<i>Dest</i>	<i>Src1</i>	<i>Src2</i>
Int Mem					
Add1 Add2 Add3					
Mult1 Mult2					
Div					

A Data Structure for Correct Issues

Keeps track of the status of Functional Units

<i>Name</i>	<i>Busy</i>	<i>Op</i>	<i>Dest</i>	<i>Src1</i>	<i>Src2</i>
Int					
Mem					
Add1					
Add2					
Add3					
Mult1					
Mult2					
Div					

The instruction i at the Issue stage consults this table

FU available?

RAW?

WAR?

WAW?

*An entry is added to the table if no hazard is detected;
An entry is removed from the table after Write-Back*

A Data Structure for Correct Issues

Keeps track of the status of Functional Units

<i>Name</i>	<i>Busy</i>	<i>Op</i>	<i>Dest</i>	<i>Src1</i>	<i>Src2</i>
Int					
Mem					
Add1					
Add2					
Add3					
Mult1					
Mult2					
Div					

The instruction i at the Issue stage consults this table

FU available? **check the busy column**

RAW?

WAR?

WAW?

*An entry is added to the table if no hazard is detected;
An entry is removed from the table after Write-Back*

A Data Structure for Correct Issues

Keeps track of the status of Functional Units

<i>Name</i>	<i>Busy</i>	<i>Op</i>	<i>Dest</i>	<i>Src1</i>	<i>Src2</i>
Int					
Mem					
Add1					
Add2					
Add3					
Mult1					
Mult2					
Div					

The instruction i at the Issue stage consults this table

FU available?

check the busy column

RAW?

search the dest column for i 's sources

WAR?

WAW?

*An entry is added to the table if no hazard is detected;
An entry is removed from the table after Write-Back*

A Data Structure for Correct Issues

Keeps track of the status of Functional Units

<i>Name</i>	<i>Busy</i>	<i>Op</i>	<i>Dest</i>	<i>Src1</i>	<i>Src2</i>
Int					
Mem					
Add1					
Add2					
Add3					
Mult1					
Mult2					
Div					

The instruction i at the Issue stage consults this table

FU available?

check the busy column

RAW?

search the dest column for i 's sources

WAR?

search the source columns for i 's destination

WAW?

*An entry is added to the table if no hazard is detected;
An entry is removed from the table after Write-Back*

A Data Structure for Correct Issues

Keeps track of the status of Functional Units

<i>Name</i>	<i>Busy</i>	<i>Op</i>	<i>Dest</i>	<i>Src1</i>	<i>Src2</i>
Int					
Mem					
Add1					
Add2					
Add3					
Mult1					
Mult2					
Div					

The instruction i at the Issue stage consults this table

FU available?

check the busy column

RAW?

search the dest column for i 's sources

WAR?

search the source columns for i 's destination

WAW?

search the dest column for i 's destination

*An entry is added to the table if no hazard is detected;
An entry is removed from the table after Write-Back*

Simplifying the Data Structure Assuming In-order Issue

- Suppose the instruction is not dispatched by the Issue stage
 - If a RAW hazard exists
 - or if the required FU is busy
- Suppose operands are latched by the functional unit on issue

Can the dispatched instruction cause a
WAR hazard?

WAW hazard?

Simplifying the Data Structure Assuming In-order Issue

- Suppose the instruction is not dispatched by the Issue stage
 - If a RAW hazard exists
 - or if the required FU is busy
- Suppose operands are latched by the functional unit on issue

Can the dispatched instruction cause a

WAR hazard? ***NO: Operands read at issue***

WAW hazard?

Simplifying the Data Structure Assuming In-order Issue

- Suppose the instruction is not dispatched by the Issue stage
 - If a RAW hazard exists
 - or if the required FU is busy
- Suppose operands are latched by the functional unit on issue

Can the dispatched instruction cause a

WAR hazard? ***NO: Operands read at issue***

WAW hazard? ***YES: Out-of-order completion***

Simplifying the Data Structure

- No WAR hazard
 - ⇒ no need to keep *src1* and *src2*
- The Issue stage does not dispatch an instruction in case of a WAW hazard
 - ⇒ a register name can occur at most once in the *dest* column
- WP[reg#]: a bit-vector to record the registers for which writes are pending
 - *These bits are set to true by the Issue stage and set to false by the WB stage*
 - ⇒ Each pipeline stage in the FU's must carry the *dest* field and a flag to indicate if it is valid
“*the (we, ws) pair*”

Scoreboard for In-order Issues

Busy[FU#] : a bit-vector to indicate FU's availability.
(FU = Int, Add, Mult, Div)

These bits are hardwired to FU's.

WP[reg#] : a bit-vector to record the registers for which writes are pending.

These bits are set to true by the Issue stage and set to false by the WB stage

Issue checks the instruction (opcode dest src1 src2) against the scoreboard (Busy & WP) to dispatch

FU available?

RAW?

WAR?

WAW?

Scoreboard for In-order Issues

Busy[FU#] : a bit-vector to indicate FU's availability.
(FU = Int, Add, Mult, Div)

These bits are hardwired to FU's.

WP[reg#] : a bit-vector to record the registers for which writes are pending.

These bits are set to true by the Issue stage and set to false by the WB stage

Issue checks the instruction (opcode dest src1 src2) against the scoreboard (Busy & WP) to dispatch

FU available?

Busy[FU#]

RAW?

WAR?

WAW?

Scoreboard for In-order Issues

Busy[FU#] : a bit-vector to indicate FU's availability.
(FU = Int, Add, Mult, Div)

These bits are hardwired to FU's.

WP[reg#] : a bit-vector to record the registers for which writes are pending.

These bits are set to true by the Issue stage and set to false by the WB stage

Issue checks the instruction (opcode dest src1 src2) against the scoreboard (Busy & WP) to dispatch

FU available?

RAW?

WAR?

WAW?

Busy[FU#]

WP[src1] or WP[src2]

Scoreboard for In-order Issues

Busy[FU#] : a bit-vector to indicate FU's availability.
(FU = Int, Add, Mult, Div)

These bits are hardwired to FU's.

WP[reg#] : a bit-vector to record the registers for which writes are pending.

These bits are set to true by the Issue stage and set to false by the WB stage

Issue checks the instruction (opcode dest src1 src2) against the scoreboard (Busy & WP) to dispatch

FU available?

RAW?

WAR?

WAW?

Busy[FU#]

WP[src1] or WP[src2]

cannot arise

Scoreboard for In-order Issues

Busy[FU#] : a bit-vector to indicate FU's availability.
(FU = Int, Add, Mult, Div)

These bits are hardwired to FU's.

WP[reg#] : a bit-vector to record the registers for which writes are pending.

These bits are set to true by the Issue stage and set to false by the WB stage

Issue checks the instruction (opcode dest src1 src2) against the scoreboard (Busy & WP) to dispatch

FU available?

RAW?

WAR?

WAW?

Busy[FU#]

WP[src1] or WP[src2]

cannot arise

WP[dest]

Scoreboard Dynamics

		Functional Unit Status										Registers Reserved for Writes			
		Int(1)		Add(1)			Mult(3)			Div(4)		WB			
t0	I_1									f6				f6	
t1	I_2	f2								f6				f6, f2	
t2										f6		f2		f6, f2	$\underline{I_2}$
t3	I_3				f0							f6		f6, f0	
t4					f0							f6		f6, f0	$\underline{I_1}$
t5	I_4					f0	f8							f0, f8	

I_1	DIVD	f6,	f6,	f4
I_2	LD	f2,	45(r3)	
I_3	MULTD	f0,	f2,	f4
I_4	DIVD	f8,	f6,	f2
I_5	SUBD	f10,	f0,	f6
I_6	ADDD	f6,	f8,	f2

Scoreboard Dynamics

		Functional Unit Status							Registers Reserved for Writes	
		Int(1)	Add(1)	Mult(3)			Div(4)	WB		
t0	I_1						f6			f6
t1	I_2	f2					f6			f6, f2
t2							f6	f2		f6, f2 $\underline{I_2}$
t3	I_3			f0				f6		f6, f0
t4				f0				f6		f6, f0 $\underline{I_1}$
t5	I_4				f0	f8				f0, f8
t6							f8	f0		f0, f8 $\underline{I_3}$

I_1	DIVD	f6,	f6,	f4
I_2	LD	f2,	45(r3)	
I_3	MULTD	f0,	f2,	f4
I_4	DIVD	f8,	f6,	f2
I_5	SUBD	f10,	f0,	f6
I_6	ADDD	f6,	f8,	f2

Scoreboard Dynamics

		Functional Unit Status										Registers Reserved for Writes			
		Int(1)		Add(1)			Mult(3)			Div(4)		WB			
t0	I_1									f6				f6	
t1	I_2	f2								f6				f6, f2	
t2										f6		f2		f6, f2	$\underline{I_2}$
t3	I_3				f0							f6		f6, f0	
t4					f0							f6		f6, f0	$\underline{I_1}$
t5	I_4					f0	f8							f0, f8	
t6								f8				f0		f0, f8	$\underline{I_3}$
t7	I_5		f10							f8				f8, f10	

I_1	DIVD	f6,	f6,	f4
I_2	LD	f2,	45(r3)	
I_3	MULTD	f0,	f2,	f4
I_4	DIVD	f8,	f6,	f2
I_5	SUBD	f10,	f0,	f6
I_6	ADDD	f6,	f8,	f2

Scoreboard Dynamics

		Functional Unit Status										Registers Reserved for Writes				
		Int(1)		Add(1)			Mult(3)			Div(4)		WB				
t0	I_1									f6					f6	
t1	I_2	f2								f6					f6, f2	
t2										f6		f2			f6, f2	$\underline{I_2}$
t3	I_3				f0							f6			f6, f0	
t4					f0							f6			f6, f0	$\underline{I_1}$
t5	I_4					f0	f8								f0, f8	
t6								f8				f0			f0, f8	$\underline{I_3}$
t7	I_5		f10						f8						f8, f10	
t8										f8	f10				f8, f10	$\underline{I_5}$

I_1	DIVD	f6,	f6,	f4
I_2	LD	f2,	45(r3)	
I_3	MULTD	f0,	f2,	f4
I_4	DIVD	f8,	f6,	f2
I_5	SUBD	f10,	f0,	f6
I_6	ADDD	f6,	f8,	f2

Scoreboard Dynamics

		Functional Unit Status										Registers Reserved for Writes				
		Int(1)		Add(1)			Mult(3)			Div(4)		WB				
t0	I_1									f6					f6	
t1	I_2	f2								f6					f6, f2	
t2										f6		f2			f6, f2	$\underline{I_2}$
t3	I_3				f0							f6			f6, f0	
t4					f0							f6			f6, f0	$\underline{I_1}$
t5	I_4					f0	f8								f0, f8	
t6								f8				f0			f0, f8	$\underline{I_3}$
t7	I_5		f10						f8						f8, f10	
t8										f8	f10				f8, f10	$\underline{I_5}$
t9											f8				f8	$\underline{I_4}$

I_1	DIVD	f6,	f6,	f4
I_2	LD	f2,	45(r3)	
I_3	MULTD	f0,	f2,	f4
I_4	DIVD	f8,	f6,	f2
I_5	SUBD	f10,	f0,	f6
I_6	ADDD	f6,	f8,	f2

Scoreboard Dynamics

		Functional Unit Status								Registers Reserved for Writes	
		Int(1)	Add(1)	Mult(3)			Div(4)		WB		
t0	I_1						f6				f6
t1	I_2	f2					f6				f6, f2
t2							f6		f2		f6, f2 $\underline{I_2}$
t3	I_3			f0				f6			f6, f0
t4				f0					f6		f6, f0 $\underline{I_1}$
t5	I_4				f0	f8					f0, f8
t6							f8		f0		f0, f8 $\underline{I_3}$
t7	I_5		f10					f8			f8, f10
t8								f8	f10		f8, f10 $\underline{I_5}$
t9									f8		f8 $\underline{I_4}$
t10	I_6		f6								f6

I_1	DIVD	f6,	f6,	f4
I_2	LD	f2,	45(r3)	
I_3	MULTD	f0,	f2,	f4
I_4	DIVD	f8,	f6,	f2
I_5	SUBD	f10,	f0,	f6
I_6	ADDD	f6,	f8,	f2

Scoreboard Dynamics

		Functional Unit Status								Registers Reserved for Writes	
		Int(1)	Add(1)	Mult(3)			Div(4)		WB		
t0	I_1						f6				f6
t1	I_2	f2						f6			f6, f2
t2								f6	f2		f6, f2 $\underline{I_2}$
t3	I_3			f0					f6		f6, f0
t4					f0				f6		f6, f0 $\underline{I_1}$
t5	I_4					f0	f8				f0, f8
t6								f8		f0	f0, f8 $\underline{I_3}$
t7	I_5		f10						f8		f8, f10
t8									f8	f10	f8, f10 $\underline{I_5}$
t9										f8	f8 $\underline{I_4}$
t10	I_6		f6								f6
t11										f6	f6 $\underline{I_6}$

I_1	DIVD	f6,	f6,	f4
I_2	LD	f2,	45(r3)	
I_3	MULTD	f0,	f2,	f4
I_4	DIVD	f8,	f6,	f2
I_5	SUBD	f10,	f0,	f6
I_6	ADDD	f6,	f8,	f2

Preview: Anatomy of a Modern Out-of-Order Superscalar Core

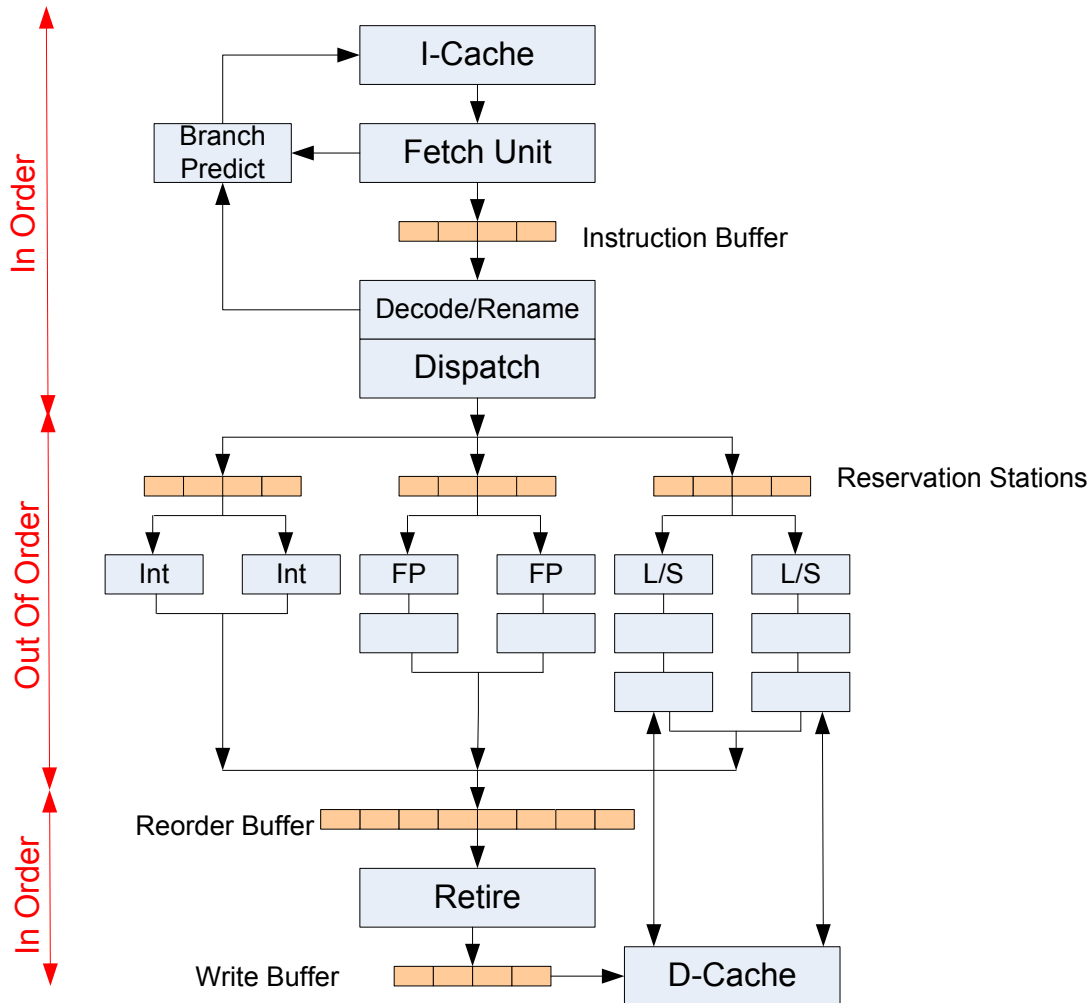

Preview: Anatomy of a Modern Out-of-Order Superscalar Core

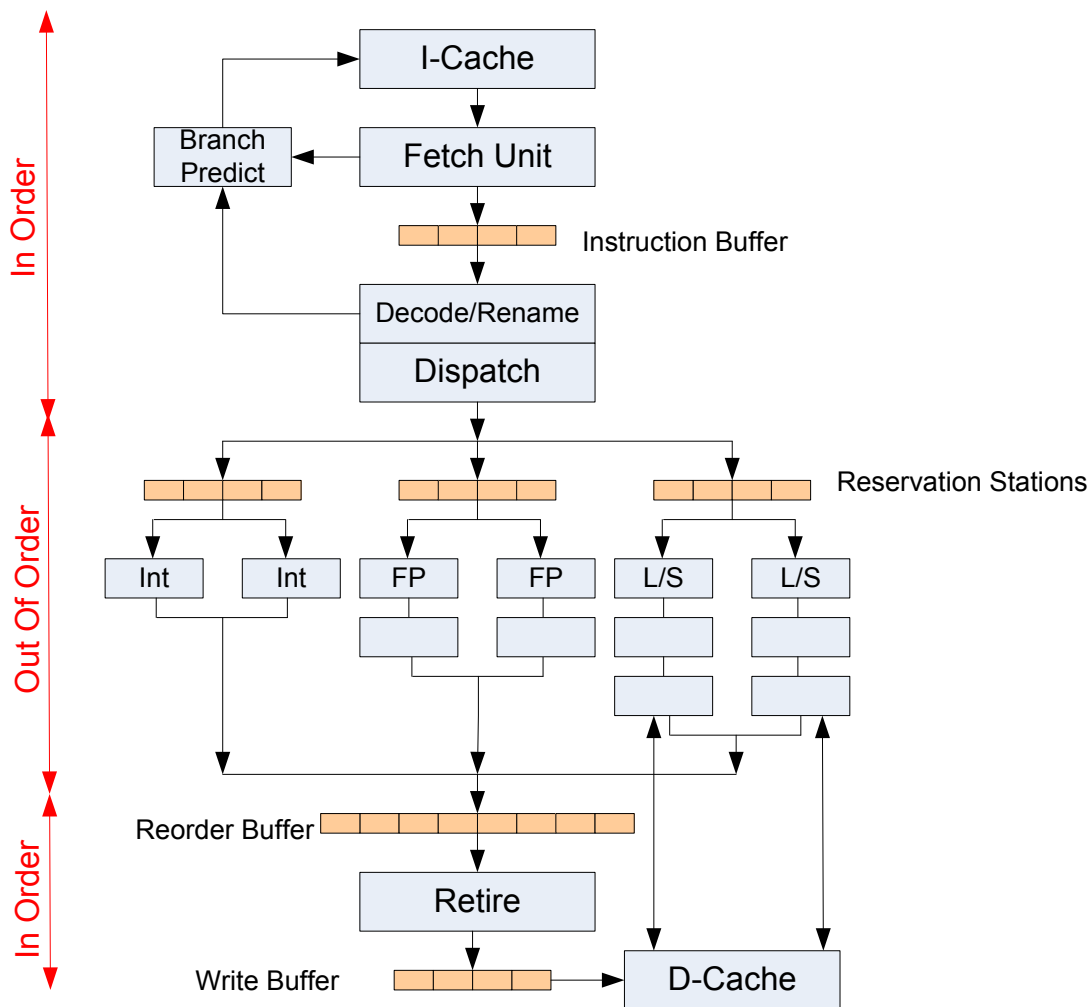

- L08 (Today): Complex pipes w/ in-order issue

Preview: Anatomy of a Modern Out-of-Order Superscalar Core

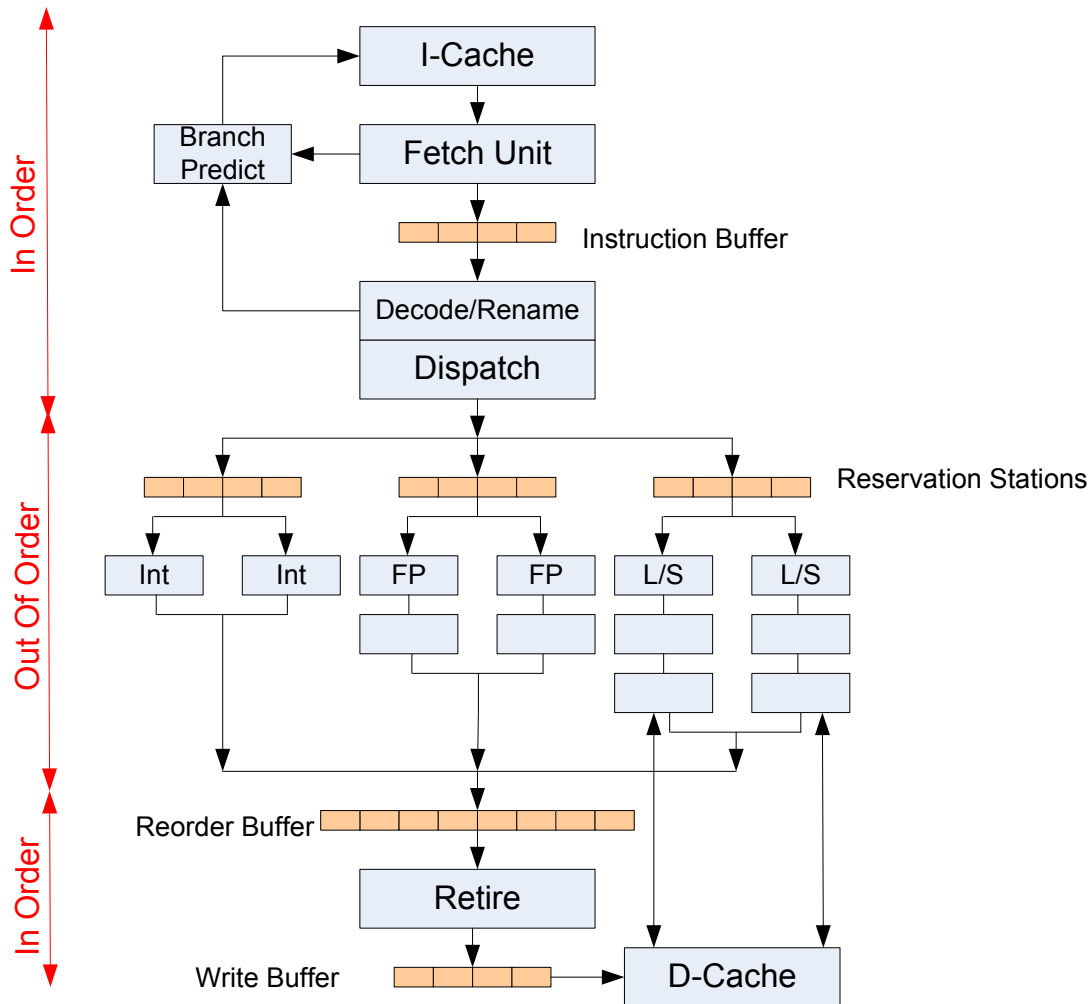

- L08 (Today): Complex pipes w/ in-order issue
- L09: Out-of-order exec & renaming

Preview: Anatomy of a Modern Out-of-Order Superscalar Core

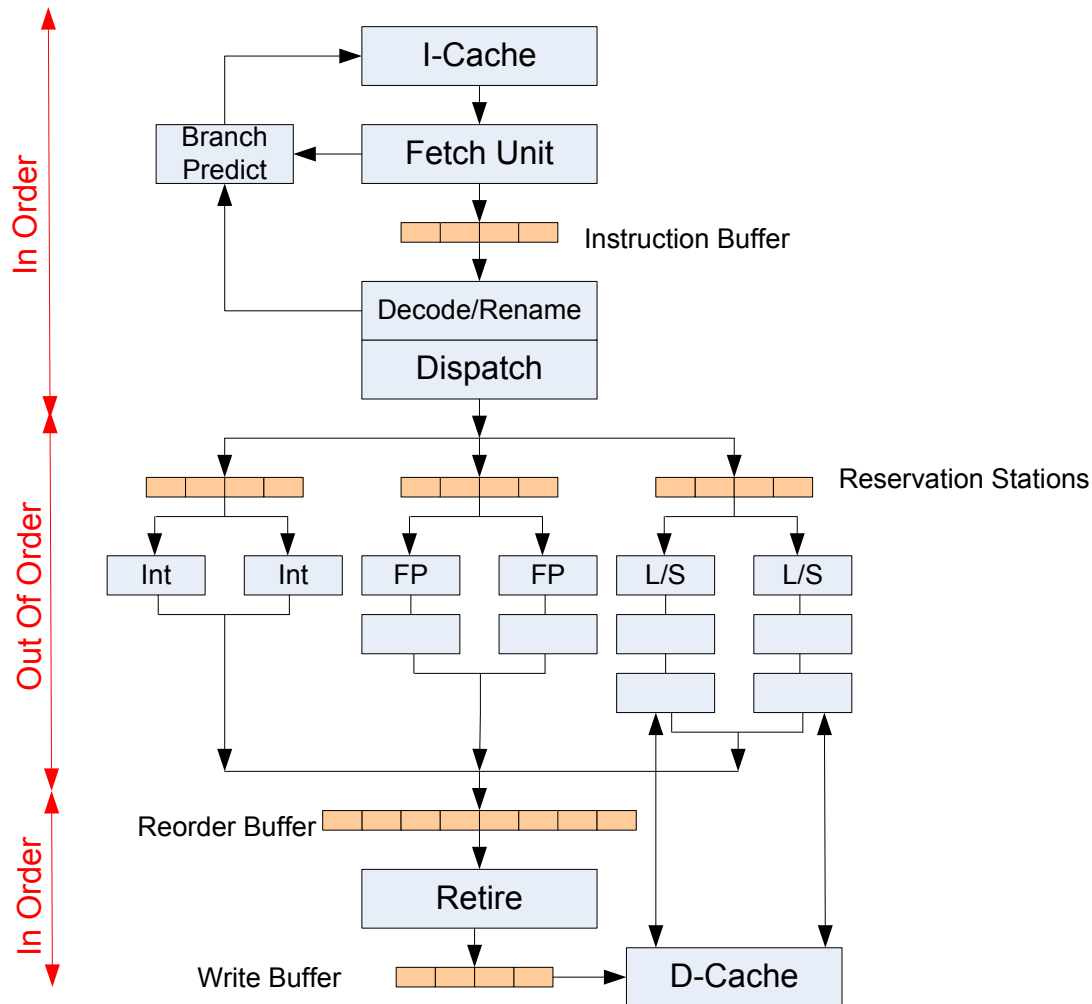

- L08 (Today): Complex pipes w/ in-order issue
- L09: Out-of-order exec & renaming
- L10: Branch prediction

Preview: Anatomy of a Modern Out-of-Order Superscalar Core

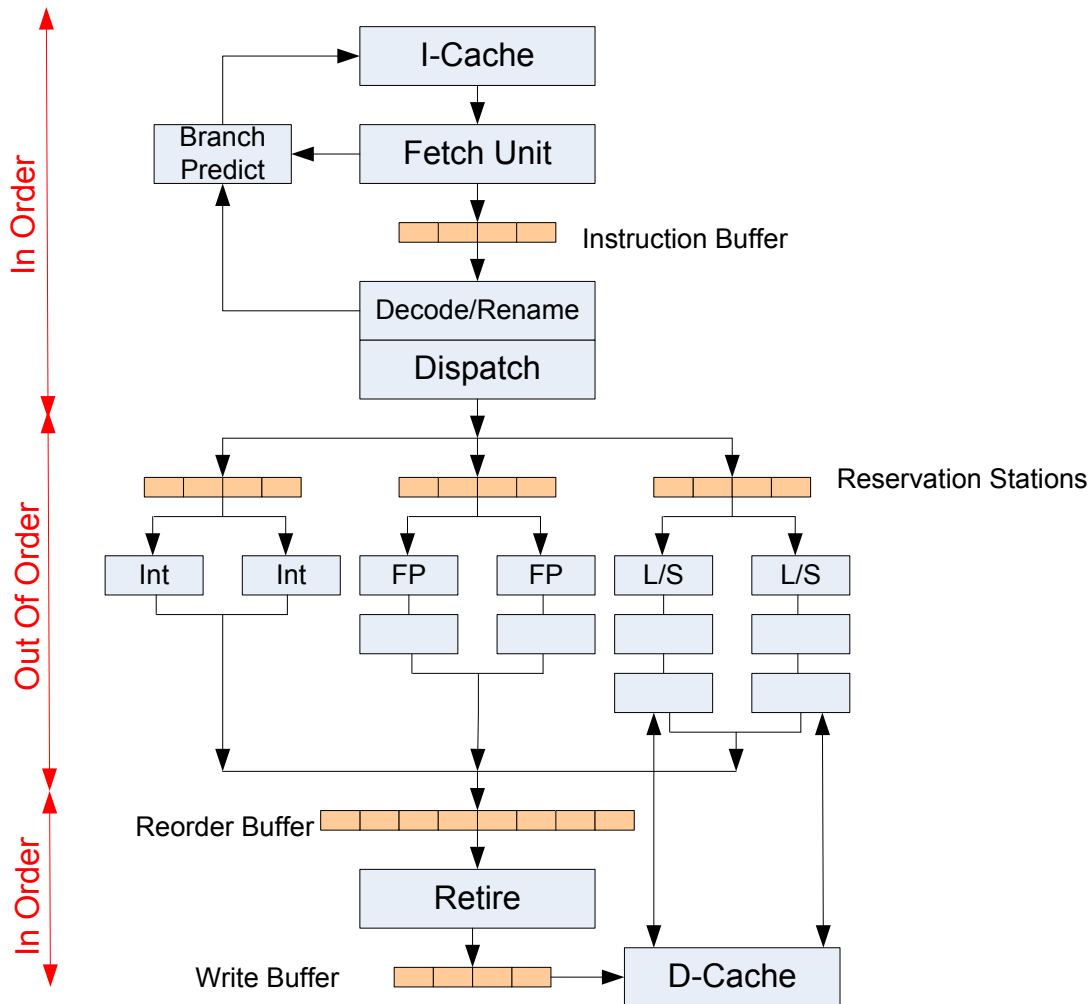

- L08 (Today): Complex pipes w/ in-order issue
- L09: Out-of-order exec & renaming
- L10: Branch prediction
- L11: Speculative execution and recovery

Preview: Anatomy of a Modern Out-of-Order Superscalar Core

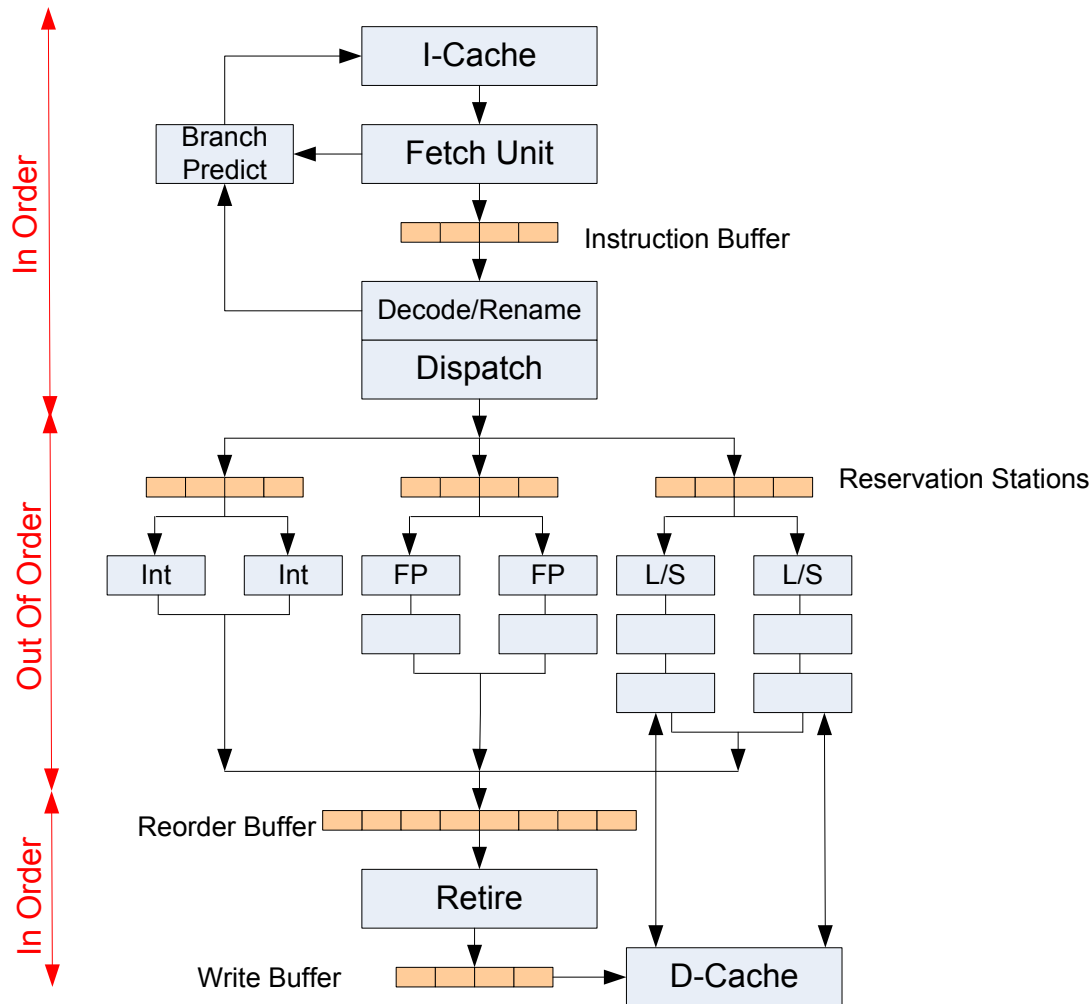

- L08 (Today): Complex pipes w/ in-order issue
- L09: Out-of-order exec & renaming
- L10: Branch prediction
- L11: Speculative execution and recovery
- L12: Advanced Memory Ops